



EN

COMPANY PROFILE



www.ceia.net

CONTENTS

SECURITY

2

FOOD QUALITY CONTROL

18

PHARMACEUTICAL
QUALITY CONTROL

22

TEXTILE AND RECYCLING

24

GROUND SEARCH

26

INDUCTION

32

RESEARCH

38

TECHNOLOGY

39

COMPLIANCE

40

QUALITY SYSTEM

41

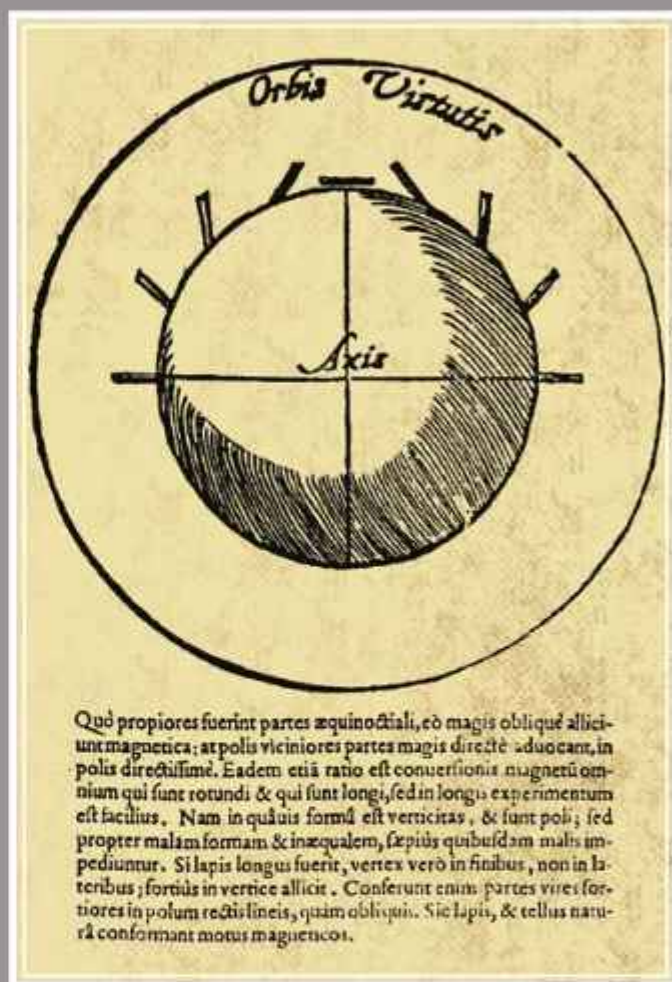

Demonstration of the behaviour of the magnetic poles through the "Terrella", a miniaturized model of the Earth and the field generated by the same, created by William Gilbert (1544-1603), the first magnetism scholar

CEIA S.p.A., Vicinaggio (Arezzo-ITALY)



CEIA HISTORY



The activity began with the production of a patented Metal Detector for the **textile industry** capable of detecting small quantities of metal in fabrics in order to protect the production machinery.



The company is incorporated as CEIA and begins development and production of **Industrial metal detectors** for food inspection, and **ultrasonic cleaning machines** for the gold and silversmith sectors.

CEIA patents the **first walk-through Metal Detector (1979)** with microcomputer-based DSP analysis and the **first column type gate (1982)**.



CEIA begins development and production of solid-state **Induction generators for no-contact heat treatment of metals**.

CEIA patents the **elliptical column walk-through Metal Detector**.



1962

1968

1975

1979
1982

1988

1990

1994

1996

1998



The growing demand for security at entrances to airports and banks stimulates CEIA to start a major research and development program.

This leads CEIA to become a major manufacturer of **walk-through and portable Metal Detectors**.



CEIA Introduces the PMD1, first multi-zone walk-through Metal Detector with full person height localization display.



CEIA starts production of the **new THS series of Industrial Metal Detectors**, characterized by state-of-the-art performance and standard all-stainless-steel construction.



CEIA's in-house EMC testing laboratory is governmentally accredited as a **"competent body in the matter of electromagnetic compatibility"**.



CEIA is selected by the **United Nations** as the Metal Detector supplier **for humanitarian demining in Afghanistan** and other conflict regions.

The company presents the **THS/PH21[®] Metal Detector**, designed to comply fully with **FDA regulations** on the criteria of construction and of electronic management of records and signatures.



The company unveils the **CEIA CMD**, a very high performance **Compact Metal Detector**.

The one-piece foldable design allows the Metal Detector to be deployed quickly and to be carried easily.



The **THS 21 Conveyor Inspection Systems** revolutionize the food market with available multi-spectrum technology, maximum flexibility, enterprise class performance and breakthrough value.

EMIS, automatic screening for non-metallic cargo, is approved by Governmental Security Authorities for use in Airports.



2002



CEIA O2PN20 is selected and certified for installation in **North American Airports** following the tightening of security standards in response to the events of **September 11, 2001**.

2003



CEIA introduces the **SAMD[®], Shoe Analyzer Metal Detector**, specifically designed to overcome the inconvenience currently experienced in examining passengers' shoes in security checkpoints.

2005

2007



CEIA Installs the first Loss Prevention System, a computer-aided metal detector designed to stop theft of valuable metal items in production plants and distribution centers.

2008

2009



CEIA EMA automatic bottled liquids scanner is certified for use in Airports.

2010

2011



CEIA introduces the **SA/80 series, the first 25, 50, 75, 100 kW High Efficiency Green Generators** with integrated Quality Data Logger and Web Server.

2013



CEIA introduces the **SAMDEX, Shoe Scanner Metal and Explosive Detector**. SAMDEX compliance to operational requirements has been successfully verified by Government-Authorized Laboratories in 2016.



TDU, Thermal Detection Unit, anti-Covid advanced embedded sensor for CEIA Security Walk-through Detector Gates.



The company presents the **OPENGATE®**, automatic screening of people with luggage, backpacks, and bags **for the detection of Mass Casualty Metal Threats** in high-throughput public places.

2014



EMIS-MAIL letter bomb and IED detector is certified for mail security inspection.

2015

2016



EMIS, automatic screening for non-metallic cargo, meets ECAC Performance Standard.

2018

2015
2019



CEIA introduces the **new multi sensor models** for ground search detectors equipped with **GPR, Metal and IED detector**.

2020

2020



Consistently with the integration and control features of existing series, CEIA expands the range of induction heating generators with the **new medium-high frequency generator SA/400**.

2021

2022

60 years after the first solid state textile metal detector, CEIA introduces the **new TE/MTZ model** which provides multi-zone indication of metal fragments position



SECURITY

CERTIFIED by
Governmental
Laboratories*

SECURITY METAL DETECTORS & SCREENING EQUIPMENT

Today's security sector and the ever-stricter regulations relating to Metal Detectors for inspecting people in transit require equipment with the highest operational and functional performance. **With over 50 years of experience in designing and manufacturing Metal Detectors, CEIA has developed a series of devices with superior sensitivity and throughput.**

In high-sensitivity applications, CEIA can detect small metallic objects, such as a single razor blade while still providing optimal immunity to environmental interference.

For high flow-rate applications, CEIA offers Walk-Through Metal Detectors with extremely high discrimination of personal metal objects to minimize the incidence of nuisance alarms.

**Data available upon request.*

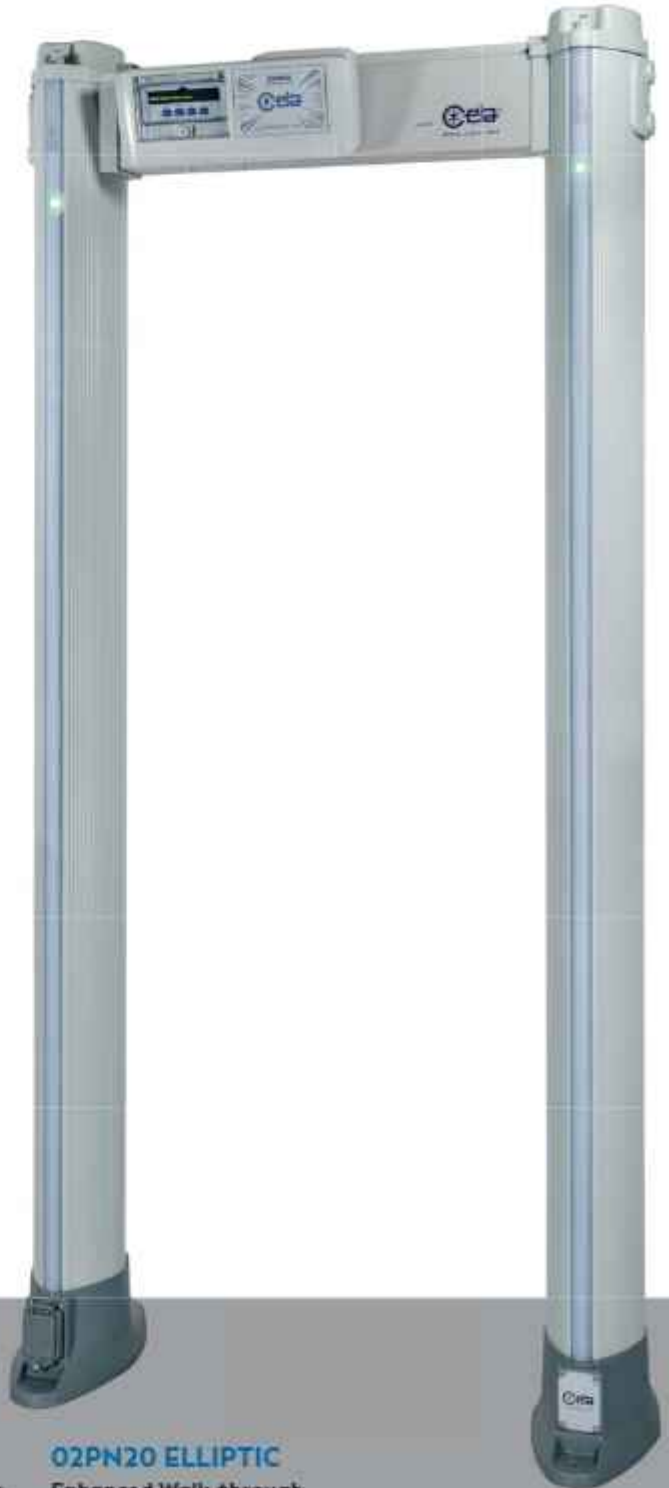

PD140N

Compact Hand Held
Metal Detection Set

PD240

Wide Search Area
Hand Held
Metal Detection Set

PD240CB

Long Range Dual-Tone
Hand Held
Metal Detection Set

O2PN20 ELLIPTIC

Enhanced Walk-through
Metal Detector

AIRPORT SECURITY



In response to the recent introduction of particularly stringent Security Standards for Walk-through Metal Detectors, **CEIA offers control equipment characterized by extremely high performance** in terms of both detection capability and transit flow. This equipment is currently state of the art.

BUILDING SECURITY

In response to the need for access controls for all those entering public buildings (government buildings, museums etc.), schools and private buildings, CEIA offers a range of very high performance walk-through and hand held Metal Detectors.

The CEIA Metal Detectors used for building access controls ensure **compliance with high security standards** and allow **easy access at both medium and high transit flow rates**.

Government buildings, museums and schools with sophisticated architecture require Metal Detectors with a modern design which can blend well into the installation site.



Sophisticated threat detection and high visitor flow rates today require **Enhanced Metal Detectors (EMD)**.



EVENT SECURITY

The considerable task of planning a major security event requires the most reliable metal detectors for security checkpoint installations.

Through its research and development laboratories, CEIA is continuously investing in the design of equipment that provides the **best compliance with the security requirements in public events**.

The results are Metal Detectors that have extremely high immunity to outside interference and **high discrimination of personal objects**. This allows a higher flow rate and improved processing times.



CEIA Enhanced Metal Detectors provide **fast and effective security** and **great visitor experience**.



CORRECTIONAL FACILITIES

SMD600 Plus & SMD601 Plus **MOST SENSITIVE METAL DETECTORS** **FOR LAW ENFORCEMENT** **AND CORRECTIONAL FACILITIES**

- Fully compliant with the NIJ-0601.02* Law Enforcement Standard
- Quick, accurate analysis of all parts of the body of people in transit, from the shoe level to the crossbar
- Accurate Pinpointing of Individual and multiple metal targets
- Exceptional Immunity to external Interferences
- Optional Integrated Cell Phone Detector (SMD600 Plus-MI2)

** NIJ STANDARD-0601.02: "Walk-Through Metal Detectors for Use in Concealed Weapon and Contraband Detection"*



**ANTI-VANDALISM
CONSTRUCTION**

CEIA provides certified Test Samples reproducing for shape, material and signal on WTMDs the same effect of the reference targets.



The CEIA Metal Detectors **fully comply with the requirements of the NIJ0601.02 Standard for all Security Levels**, and can therefore be applied in situations from the inspection of visitors to that of inmates in top-security checkpoints, even in areas with strong electrical and mechanical interferences.

LOSS PREVENTION

OPTIMISED SOLUTIONS TO DETECT AND DETER METAL PRODUCT THEFT

- Discovers small metal masses anywhere on and in the body while discriminating non-removable metal
- Greatly reduces losses with theft detection and deterrence
- Increases throughput at security checkpoints with automated screening
- Minimizes nuisance alarms by ignoring non-removable personal metal items
- Improves privacy with non-invasive search



As people transit the system, their metal content is compared to a saved personal profile.

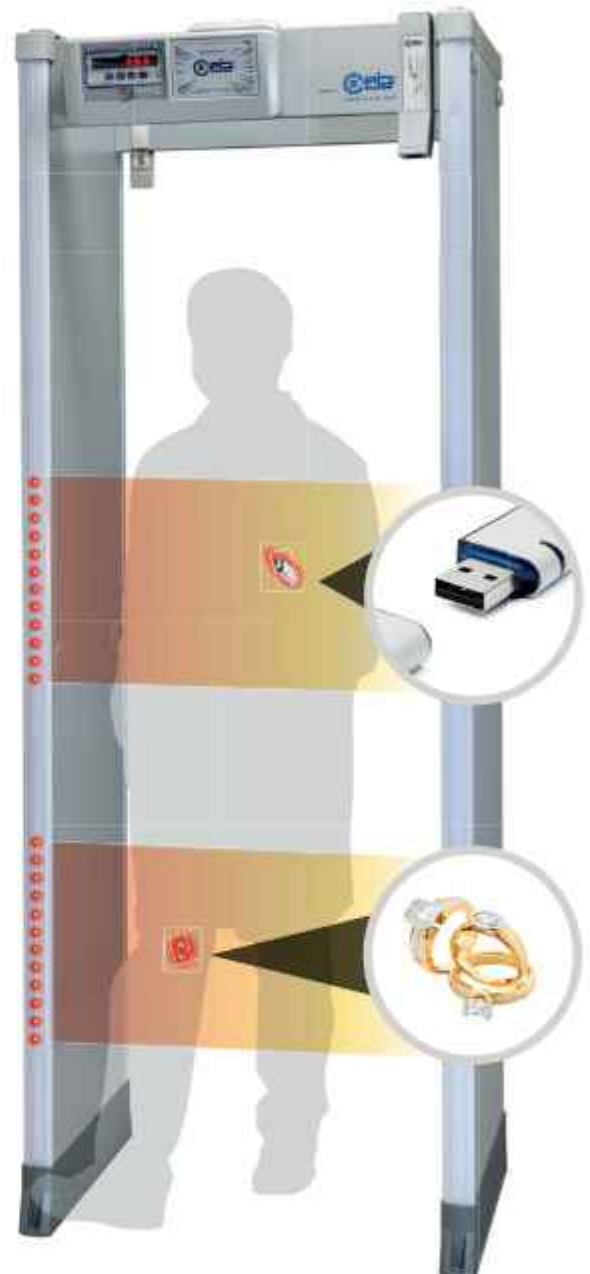

The SMD601 Plus Loss Prevention Metal Detector prevents the theft or accidental removal of metallic objects.



WEAPONS AND RADIOACTIVE MATERIALS DETECTOR

DUAL THREAT DETECTION IN A SINGLE GATE

The CEIA Walk-Through Metal Detectors can be **equipped or field upgraded after the installation with a high sensitivity array of gamma sensors**. This array covers the full height of the transit, allowing accurate detection of radioactive substances carried by people in transit.

The detection capability includes a wide range of energies for a complete coverage of the possible radioisotopes. The gamma detectors adapt themselves to the background radiation level, adjusting the threshold to the optimum value for the installation environment. At the same time, a special algorithm prevents the adaptation to unusual background levels and changes.



The gamma-ray detection technology utilized in the CEIA Walk-Through Metal Detectors has been tested in Government-Authorized Laboratories.

G-SCAN RADIATION DETECTOR

Checkpoint Security coverage can be completed by a G-SCAN Radiation Detector positioned at the exit of the carry-on baggage inspection X-Ray machine.



SHOE EXPLOSIVE (SED) AND METAL (SMD) DETECTOR

STAC
Certified

DfT
Approved

SAMDEX®

- SED & SMD Integrated unit
- Certified against relevant detection standards for explosive and metallic threats
- Bulk detection, based on actual material properties measurement
- Clear "OK/ALARM" Inspection result
- Increased checkpoint throughput by elimination of shoe divestiture and X-ray check
- Increased comfort: passengers keep their shoes on
- Ergonomics: simple and stress-free use
- Analysis time: 2 sec. typical/shoe

Guided use is provided through proper graphic animations.



Passenger Screening with WTMD + SAMDEX and passenger body control through Explosive Trace Detector (ETD).

LIQUID EXPLOSIVE DETECTOR

Type B
Standard 3
Certified

Type A
Standard 3
Certified

TSA
Qualified

EMA SERIES

The EMA is a compact device designed for **the screening of bottles and their contents with the goal of detecting the presence of combustible, flammable and explosive liquids**. When the operator places the bottle in the inspection cavity, the measurement process starts automatically.

The entire volume of the bottle is analysed in order to verify its conformity with benign liquids. **After a few seconds, the unit provides an OK or Alarm message without requiring any data interpretation by the operator**. Calibration is carried out automatically by the unit. The electromagnetic fields generated in the inspection cavity are weak in intensity and non-ionizing, therefore completely safe for the liquids and for the operator.



Examples of liquid containers that can be screened with EMA.



NetID[®] NETWORK MANAGEMENT SYSTEM

The NetID Network Management System has been supervising CEIA IP enabled Metal Detectors since the year 2001. Today 150 instances of NetID[®] Systems are in active use worldwide managing more 250 different sites.

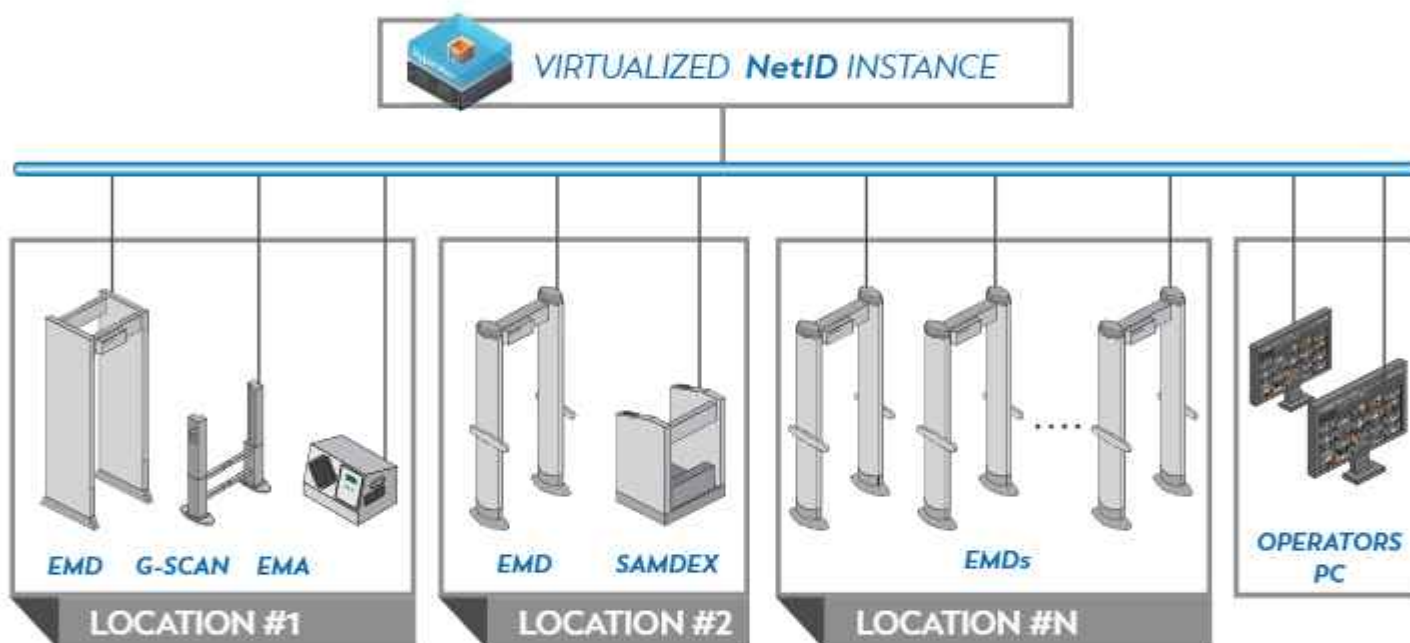

MONITOR



CONTROL



REPORT

- Centralized Monitoring of the functionality of each Metal Detector
- Centralized Setting of the Metal Detectors working parameters
- Transits flow monitoring
- Detailed reporting of the transits data and the security device configuration data
- Data collection from each Metal Detector detailing the information on every single transit

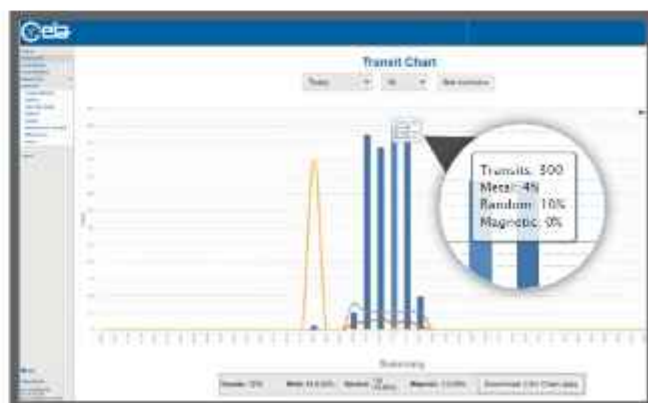

THERMAL PEOPLE SCREENING

TDU THERMAL DETECTION UNIT

Good-health advanced embedded sensor for CEIA Security Walk-through Detector Gates

- Designed for fast and cost effective screening operations
 - ▶ Simultaneous threat and fever detection
 - ▶ No separate screeners for person temperature control needed
 - ▶ On-the-fly temperature measurement, no need to stop
- Embedded upgrade
 - ▶ No additional installation checkpoint space required
- Automatic detection of high body surface temperature through infrared thermal camera that maps the internal gate area
- Real-time, highly selective, maximum facial-temperature measurement function
- Exclusive integrated thermal calibration system with Dual Temperature-Stabilized Reference
- Selective measurement on one person only in transit
- Easy to install and to operate
- Stainless steel and technical polymers construction

ANTI-COVID
SECURITY SOLUTION



Temperature compliance and alarm signalling are provided by the gate control unit display.



HIGH FOOTFALL SCREENING

OPENGATE®

Automatic screening of people with luggage, backpacks, and bags for the detection of Mass Casualty Metal Threats in high-throughput public places

- ✓ OPENGATE is the first wire-free, screening portal consisting of two independent and self-powered pillars, with each pillar equipped with a support base and electronic analysis system
- ✓ Contrary to Metal Detector Gates, OPENGATE does not require a mechanical and electrical connection between the two transducers that define the passageway
- ✓ Acoustic and optical signals, located at the top of the pillars, provide simultaneous status and alarm indications
- ✓ OPENGATE features a near zero rate of nuisance alarms, and operates with high transit flow, without the need for the divestiture of non-threat items



✓ EASY TO RELOCATE AND QUICK TO INSTALL

✓ OPENGATE APP: OPERATIVE SCREEN

LETTER BOMB AND IED DETECTOR FOR MAIL AND PARCEL INSPECTION

EMIS-MAIL FOR MAILROOM SECURITY

- Automatic inspection of parcels and letters up to 45 cm in width and 7.5 cm thickness
- Detection of detonators, batteries, trigger circuits and other metallic components of letter bombs
- No alarm on metal staples, paper-clips and metal binding spirals
- Ergonomic, compact design
- Confirmation of signal (OK/ALARM) for each package inspected
- Operates on mains power supply and with NIMH rechargeable batteries (opt.)
- No calibration or periodic maintenance required
- Integrated battery charger
- Optional embedded radioactive material detector



Scan QR code
to see video
presentation

The EMIS-MAIL is very easy to use and provides a fast and automatic OK/ALARM signal confirmation per each inspected package.

CELL PHONE, FERROUS WEAPON AND CONTRABAND DETECTOR

MSD FERROMAGNETIC DETECTOR

- Detection of all cell phones and other ferrous contraband concealed on the person or in body cavities (Including keyfob cell phones, smart phones, radio transceivers, etc.)
- Constant Sensitivity across the detection area in pass-through operations
- Multi-Zone targeting indication identifies location of contraband on the body
- Covert operation through use of Bluetooth headset
- Fully weather proof for outdoor use (IP65 certified)
- 26 hours continuous operation
- Unmatched detection in all environments without adjustment
- Extremely durable design
- No assembly required: set-up in less than 10 seconds



TARGET
PINPOINTING
INDICATION

ONE-PIECE AND
LIGHTWEIGHT
DESIGN
(total weight
only 9.5 kg)

READY FOR
IMMEDIATE USE



AUTOMATIC SCREENING FOR NON-METALLIC CARGO

The *EMIS* is designed to automatically detect detonators and metal components of explosive devices inside paper, newspaper, perishable goods such as produce, fish and meat (fresh or frozen) and organic material in general.

EMIS SERIES

The EMIS (Electro-Magnetic Inspection Scanner) equipment are security screening devices designed to inspect non-metallic cargo.

Using CEIA exclusive Electromagnetic Profile Analysis technology, these devices ensure automatic detection of detonators and electronic circuits from IEDs (Improvised Explosive Devices), ammunition and weapons composed of metal (knives, firearms). In case of detection, the scanners give an audible and visual alarm.

The advanced technology employed in the EMIS minimizes the interaction with the goods themselves and does not depend on visual interpretation of an image by an operator.

Electromagnetic inspection is the most suitable and quickest method for checking non-metallic cargo.



EMIS 8075 for package inspection.

INSPECTION OF

- Perishable goods and flowers
- Paper products
- Textiles and Clothing
- Plastic and wooden products





Meet ECAC
Performance
Standard



TSA
Qualified

EMIS 130200 for palletized cargo.

ADVANTAGES / BENEFITS

Detect automatically detonators and metal components of explosive devices:

- Low cost of ownership
- No dedicated operator
- High throughput
- No ionizing radiation
- Completely solid-state construction (no periodic maintenance or calibration required)



FOOD QUALITY CONTROL

Supermarket
specifications
compliant

CEIA THS 21 Metal Detection Systems offer detection, construction quality and reliability characteristics that make them the most suitable and effective solution for automatic elimination of metal contaminants

CEIA Metal Detectors detect metal contaminants accidentally present in Industrial products with levels of sensitivity, immunity to interference and response speeds exceeding the strictest Quality Control Standards.

Fully HACCP and GMP compliant, CEIA Metal Detectors are ISO 9001 certified and constructed of EC and FDA approved materials.

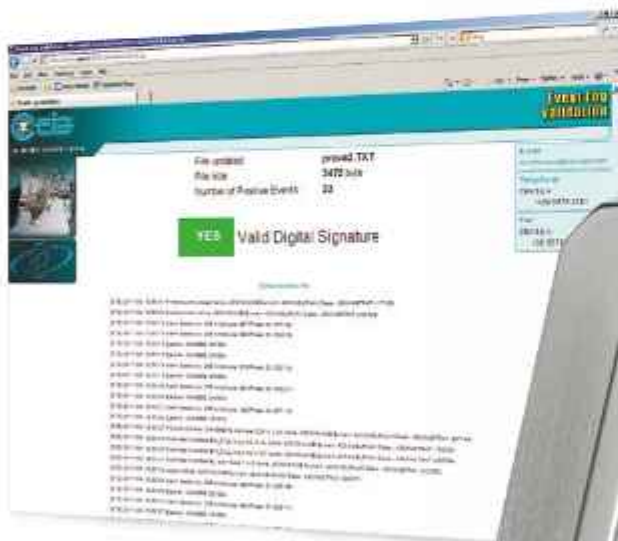

The THS 21 Metal Detector Series is a high-sensitivity, high-precision measuring instrument. The data relating to each detection and ejection are stored in an events memory and certify production quality.





THS 21 SERIES WITH MULTI-SPECTRUM TECHNOLOGY

Exclusively developed by CEIA, this is a unique metal detection technology that both optimizes sensitivity to all metal contaminants and minimizes product effect in a very wide range of possible products

By recognizing the different frequency response of conductive products and metals, **this innovative technology cancels product effect and maintains high performance levels for all types of metal contaminants, both magnetic and non-magnetic.**

The autolearn function used by CEIA Multi-Spectrum Metal Detectors equates to the repetition of hundreds of conventional transits. It explores the whole spectrum of available frequency bands in order to determine the best operating conditions resulting in unique detection performance.



THS/FFV21
Free-fall Integrated system
with metal detector and
ejection valve

**THS 21 Conveyor Inspection
Systems for vertically
oriented products.**



CONVEYOR INSPECTION SYSTEMS



CEIA THS 21 Conveyor Inspection Systems satisfy the most stringent requirements for functionality, compact construction, accuracy and reliability of response in dealing with accidental contamination in food products.

CEIA's THS 21 are available in a wide range of sizes covering the different application requirements. The supporting structure, the Metal Detector and the belt control box are in stainless steel.

The conveyor belt is certified as fully compatible with food product handling (FDA/USDA compliant) requirements, as is the protective cover of the ejection area and the container for rejected products.



UNEQUALLED INTEGRATED I/O AND COMMUNICATION CONNECTIVITY PERFORMANCE



PIPELINE INTEGRATED SYSTEMS



The CEIA Integrated systems are especially designed for metal contaminant detection in products transported by pipeline especially meat, soup, preserves...

The carefully selected materials used in construction do not interact with food products, and thus do not modify or alter their composition. The design of these systems incorporates a fast reject valve drive response time to detect and reject the contaminant without slowing down the product flow.

The construction guarantees quick, easy cleaning of the components that are in contact with the product. The technological choices made by CEIA allow the parts in contact with the product to be disassembled and maintained in a short time.



THS/PLVM 21 series: Integrated System for applications on meat vacuum filler machines.



THS/PL 21 SERIES

PASS-THROUGH INTEGRATED SYSTEM FOR LIQUID AND VISCOUS PRODUCTS



THS/PLV 21 SERIES

PASS-THROUGH WITH EJECTION VALVE INTEGRATED SYSTEM FOR LIQUID AND VISCOUS PRODUCTS



THS/PLVM 21 SERIES

PASS-THROUGH WITH EJECTION VALVE INTEGRATED SYSTEM FOR APPLICATIONS ON MEAT VACUUM FILLER MACHINES

PHARMACEUTICAL QUALITY CONTROL

THS/PH21N Pharmaceutical Metal Detection Systems feature extremely high detection sensitivity towards contaminating metals, whether ferrous, non-ferrous or stainless steel, even when present in tiny quantities.

The design and construction of the THS/PH21N Metal Detection Systems comply with **FDA Title 21 CFR 110 requirements**. The carefully-selected materials used in construction do not interact with pharmaceutical products, and thus do not modify or alter their composition. The mirror finished surfaces guarantee quick, easy cleaning of the components that are in contact with the product. The technological choices made by CEIA allow the parts in contact with the product to be disassembled and maintained in a short time and without the use of machine-specific tools.



THS/PH21N: Ultra High Sensitivity Metal Detector.



THS/PH21N-G70-FFV: Integrated System for Granular and Powder Products.



KEY FEATURES

- High Sensitivity to all metals
- Integrated Controls for line speed and rejection
- High Immunity to environmental interference
- Automatic Learning & Tracking of product effect
- Digitally adjustable belt speed
- Design and Construction compliant with GMP criteria and 21 CFR part 210 & 211
- AISI 316L stainless steel construction



THS/FBB for effervescent tablets inspection.



THS/PH21N-WIP: Wash-in-Place Metal Detection System.



THS/FBB for plastic tubes and sanitary packages inspection.



THS/MBB for vertically oriented products.

TEXTILE AND RECYCLING

TE & TE/MTZ DIGITAL METAL DETECTORS

The **TE Digital Metal Detectors** are the ideal means of protection for production lines against accidental damage caused by fragments of metal which can enter the manufacturing process along with the material.



- Ultra high Sensitivity to all magnetic and non-magnetic metals, including stainless steel
- Compact and robust construction
- Durable detection surface
- High electrical and mechanical Immunity
- Wide Detection Speed range, from 1 up to 600 m/min
- Easy Installation and setting
- Multi-Zone model available (TE/MTZ)



Examples of detectable metal fragments



SDT DIGITAL METAL DETECTOR

The **SDT digital Metal Detector** detects magnetic and non-magnetic metal fragments of small to medium dimensions in recycling industrial, textile, chemical, mining, foodstuffs and other products, both for quality control and machinery protection.

- High sensitivity to all metals
- Openable AISI 316 stainless steel construction system
- Compact and robust construction
- High Immunity to environmental Interference
- Wide Detection Speed range, from 1 up to 600 m/min
- Easy installation and setting on existing conveyor without belt opening



THS/TT METAL DETECTOR

The **THS/TT Metal Detector** detects metal contaminants accidentally present in pipelines (i.e. in pneumatic lines), with levels of sensitivity, immunity to interference and response speeds designed to satisfy the strictest protection control requirements.



Digital control panel.

GROUND SEARCH

GROUND SEARCH METAL DETECTION

Thanks to many years of in-depth research in the field of Metal Detection, CEIA has established itself as a **primary manufacturer of high-performance Ground Search Metal Detectors**.

CEIA's approach to the development of its Detectors has been to employ **the most advanced electronic and mechanical technologies that become available**: Surface Mount Technology (SMT), microprocessor control, Digital Signal Analysis, in-the-field software upgrade capability and the use of high-quality materials for the search probes and for the other mechanical parts.

Tests carried out under controlled conditions by Authoritative International Bodies demonstrate that the CEIA Metal Detectors provide overall superior performance in the areas of detection distance, soil compensation capability and immunity to external interference.

Thanks to the extensive use of robotic and automated production systems, CEIA is able to offer the humanitarian market equipment that satisfies military quality and reliability standards at extremely competitive prices.



CEIA HUMANITARIAN CLEARANCE TEAM WORK

Working in conjunction with Humanitarian Clearance Teams around the world, CEIA has developed a series of detectors that can easily be operated together to deal with Mines, EOD, IED and Command Wire clearance requirements.

CMD series

Lightweight, Compact Metal Detector for Mines, IEDs and UXOs

- Extremely easy to compensate and operate
- Built in Battery Charger, Fully Digital Design
- Immune to EMI, Continuous self-Calibration



DSMD

Digital Deep Search Metal Detector for UXO and Cluster Munitions Detection

- Easy Operations with pin pointing capability
- GPS with Data Tracking capability
- Single person operation with built in Battery charger and easy to understand display
- Integrated GPS or External DGNNs with Data Tracking capability

MIL-D1

Dual Tone, Digital Metal Detector

- Effective detection of magnetic and non-magnetic metal masses
- Accurate pinpointing of the target's position
- Compensation for mineralized and high natural metal content soils



MULTI-SENSOR TECHNOLOGY

COMPACT TRIPLE-SENSOR METAL, CARBON ROD AND COMMAND WIRE DETECTOR

- MD** • **HIGH DETECTION SENSITIVITY** of magnetic and non-magnetic **LOW METAL CONTENT MINES** in all soil conditions
- CRD** • **ENHANCED IED DETECTION** of targets such as electrical conductive, non-metallic devices (i.e. graphite switches), short wires and high resistivity metals
- WD** • **COMMAND WIRE DETECTION** of conductors of any diameter and type with no nuisance alarms due to other metal targets and clutter



Thanks to many years of in-depth research in the field of Electromagnetics Designing and Manufacturing, CEIA has developed a complete range of devices with superior detection capabilities addressing traditional and new requirements.

INTEGRATED PRECISION GPR, METAL AND CARBON ROD DETECTOR

GPR

- **GPR SENSOR** for the detection of Dielectric Anomalies and discontinuities of the soils such as jars filled with explosives, crates and cavities

MD

- **HIGH SENSITIVITY TO DETECT LOW METAL CONTENT MINES** containing magnetic metal, non-magnetic and mixed alloys in all soil conditions

CRD

- **ENHANCED CAPABILITY TO DETECT A WIDE RANGE OF UNCONVENTIONAL TARGETS USED IN IEDs** such as electrical conductive, non-metallic devices (i.e. graphite switches), wires (even of limited length and in a wide range of diameters) and high resistivity metals



EMYS is a complete system, aimed at the detection of metallic UXOs and ERWs, designed to be installed in front of vehicles.

In the box, remote display unit inside the vehicle.



MDA2

for Submarine Operations

Metal Detector equipped with a linear antenna array designed to operate attached to a manned or unmanned submersible vehicle and capable of functioning at depths up to 300 m.



PD240CBM

Hand held Urban Clearance Tool

Detection of:

- Crush wires
- Carbon Rods
- Other conductive IED Components
- Even in urban metal contaminated environment
- People Screening



CEIA TRAINING FACILITY

COMPLETE SUPPORT FOR TECHNICAL AND OPERATIONAL COURSES

CEIA provides complete support for technical and operational courses, given by certified personnel, either on site or at its own premises. The curriculum includes first and second line maintenance, training for operators and a course for operator instructors.

A brand new facility, specifically designed for operational and maintenance training courses, has been recently set up at CEIA headquarters.

The facility extends the already existing training site. It consists of an expanded **outdoor training lanes area**, dedicated to practical activities and testing over different soils and **a training building for theory lessons and technical maintenance procedures.**

- FIRST AND SECOND LINE MAINTENANCE
- OPERATOR TRAINING
- TRAINER-TRAINING PROGRAMS



INDUCTION

INDUCTION HEATING SYSTEMS

For more than 40 years CEIA has been working on the design and manufacture of no-contact Induction Heating Devices for metal treatment. High and medium-frequency generators, control units, optical sensors for measuring temperature and automatic solder-alloy wire feeder devices make up the line of products known as the **Power Cube Family**, which are ideal for industrial processes of heat treatment and braze welding.

CEIA's unique technological solutions allow the manufacturing of power equipment with compact size, calibrated output power, extremely high-energy efficiency and long-term reliability. The high performance they offer contributes to the widespread use of CEIA systems in the most important industrial fields, where they have received the approval of end users and final-product manufacturers.



POWER CUBE® SA/80 SERIES: Wideband Low-Medium Frequency 150, 100, 75, 50, 25 kW Generators



POWER CUBE® SYSTEM 900: Precision Induction Heating Generator & Controller.

CEIA's unique technological solutions allow the manufacturing of power equipment with compact size, extremely high-energy efficiency and long-term reliability.

GENERATORS



THE CEIA SYSTEM'S ADVANTAGES

- **EFFICIENCY AND COMPACTNESS**
 - ▶ High level of performance with minimal operating costs
 - ▶ Lower energy consumption
- **COMPLETE OPERATOR SAFETY**
 - ▶ EMC and CE certified
 - ▶ Standard Galvanic isolation
- **PROCESS CONTROL AND REPEATABILITY**
 - ▶ Auto frequency tuning for optimal energy transfer to any load
 - ▶ Certified stability of power output
- **RELIABILITY AND FLEXIBILITY**
 - ▶ MTBF certified



CONTROL UNITS

The **Master Controller V3+** is a multifunction industrial control unit, designed for automatic management of programmable heating processes. All operating parameters for each phase of the heating cycle can be programmed within a wide range of values.



TEMPERATURE SENSORS



SH/SLE COMPACT OPTICAL PYROMETERS

CEIA offers a wide range of infrared optical sensors, equipped with low-intensity LED aiming, which covers an **operating temperature range from 80°C to 2200°C**.

- **SH15/SLE**
 - ▶ Single-color Series from 80°C to 2000°C
- **SH2C/SLE**
 - ▶ Dual-color Series from 600°C to 2200°C



SH/SLE PYROMETER
Pyrometer mounted on ES3M micrometric optical sensor base.



CALIBRATION CERTIFICATE

Digital Factory Testing, accurate automated calibration and final individual report of the delivered equipment, according to certified references.



ELECTROMAGNETIC COIL DESIGN AND ENGINEERING CAPABILITY

▶▶ CONCEPT

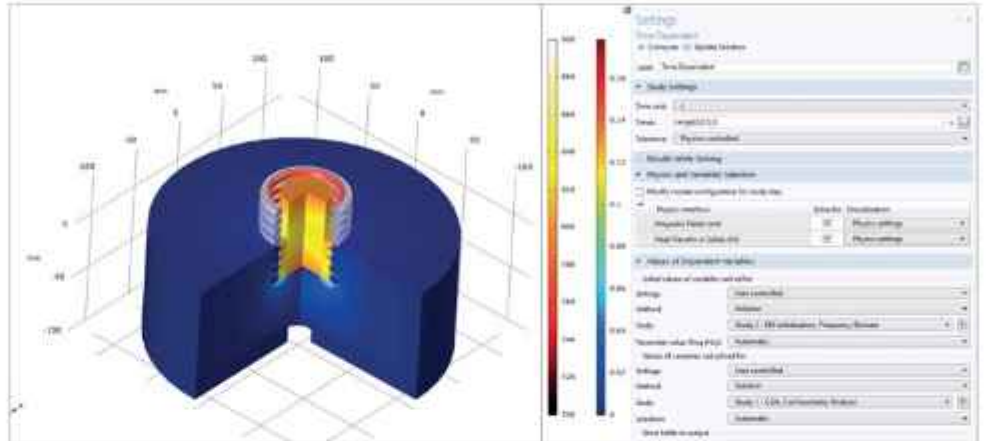
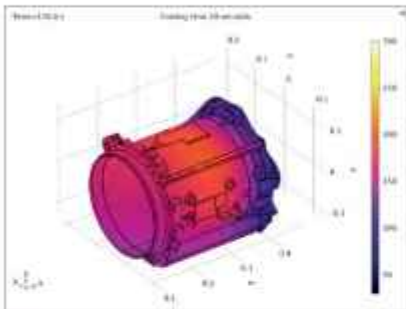

Detailed electromagnetic modeling and analysis to achieve the customer's heating requirement

▶▶ DESIGN



Development of coil design by advanced CAD-CAM software

▶▶ VALIDATION

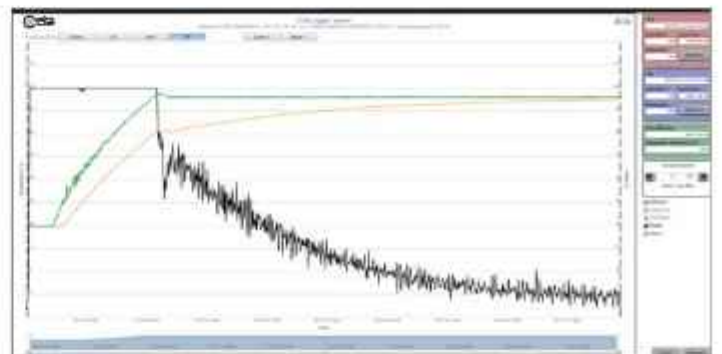
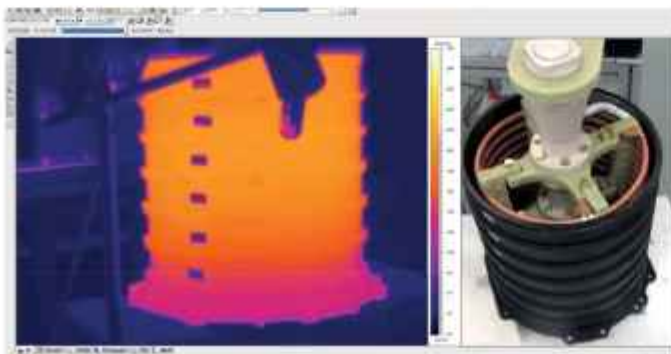

Dedicated laboratory for final testing and validation

EXAMPLES OF APPLICATIONS

▶ BRAZING / SOLDERING



▶ HEAT TREATMENT



▶ ELECTRIC MOTORS ASSEMBLY

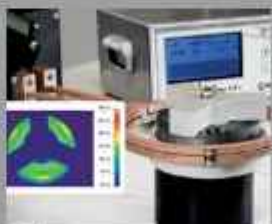

RESEARCH



Professional Qualifications and Experience

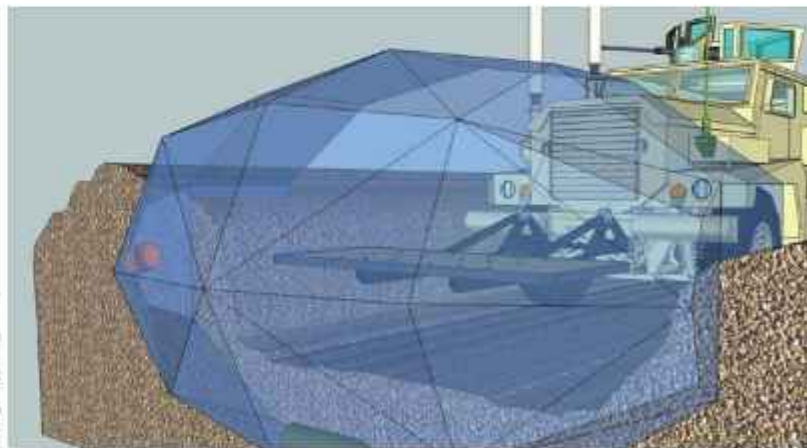

CEIA maintains its dedication to cutting edge electromagnetic research. Nearly 20% of CEIA's staff is focused on researching tomorrow's threat detection technology using electromagnetics.

TECHNOLOGY



Advanced Technology Production Systems



The quality and reliability levels of CEIA equipment are recognized throughout the world by private companies and governmental institutions, who have chosen it following stringent comparative testing. This objective has been achieved by using the most advanced technology in all phases of production.

COMPLIANCE



CEIA LACE

Laboratory of Electromagnetic Compatibility

www.emc-lace.com



User safety is a primary focus of CEIA product development. All CEIA equipment meets or exceeds local and international standards for electromagnetic emissions and immunity as well as electrical safety standards used worldwide.

The CEIA EMC Laboratory is accredited according to the ISO/IEC 17025 standard.

QUALITY CONTROL

CEIA equipment has a strong reputation for reliability and maintenance-free operation. This is achieved through extensive factory testing for product conformance to strict internal standards.

Detailed adherence to ISO 9001 standards also provides the traceability to support clients for many years after their equipment goes out of production. The tight tolerances employed during the factory acceptance test produce such consistent devices that field calibration is not required.



THS Production for statistical and operational management of networked THS 21 systems.

Electronic Boards Functional Burn-In: 200 hours minimum.

Mechanical shock test on MIL-D1 Digital Metal Detector.

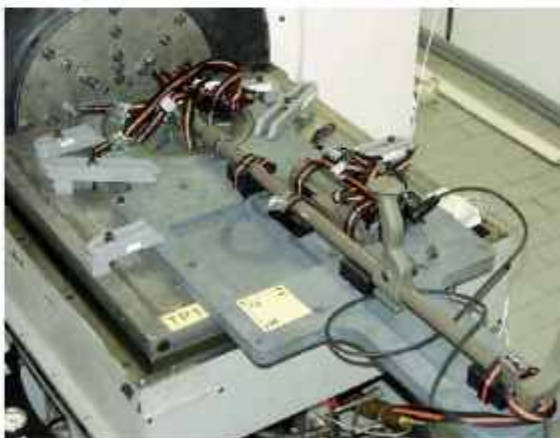
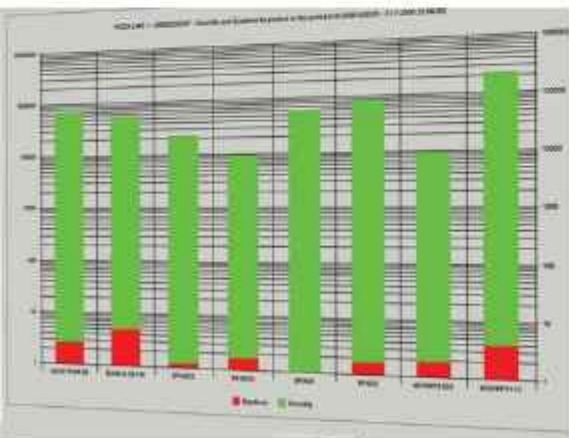

CEIA's Quality System extends throughout the company, from the design stage through production, quality control and after-sales service.

APPLICATIONS

SECURITY

Airports and Ports, Embassies,
Military Installations, Industry, Penal
Institutions, Government Buildings,
Banks, Stadiums, Public Events,
Distribution Centers, Data Processing
Centers, Hospitals

INDUSTRIAL

Food, Pharmaceutical, Textile, Mining,
Chemical, Manufacturing

GROUND SEARCH

Humanitarian Demining, UXO
Clearance, Underwater Detection,
Crime Scene Investigation, Vehicle
Protection

INDUCTION

Brazing, Cap Sealing, Forging,
Hardening, Localized Heating, Melting,
Metal Glass Sealing, Sintering,
Tempering, Tin Soldering





CEIA S.p.A. Headquarters, Vicinaggio, Arezzo (Italy)



CEIA USA Ltd., Hudson, Ohio (USA)



CEIA International SAS, Paris (France)



CEIA Limited, Alcester, Warks (UK)



CEIA GmbH, Wiesbaden (Germany)



CEIA IBÉRICA S.L., Barcelona (Spain)



LTB GmbH (CEIA Group), Weil der Stadt (Germany)

COMPANY PROFILE



DP000K0010v1000hUK - 111289



COSTRUZIONI ELETTRONICHE INDUSTRIALI AUTOMATISMI

Zona Industriale 54 • 52041 Vicinaggio, Arezzo (ITALY)

T +39 0575 4181 • E info@ceia-spa.com



www.ceia.net