

DESETEC SPANNTÉCHNIK

M-Serie Manuelle Spannelemente

P-Serie Pneumatische Spannelemente

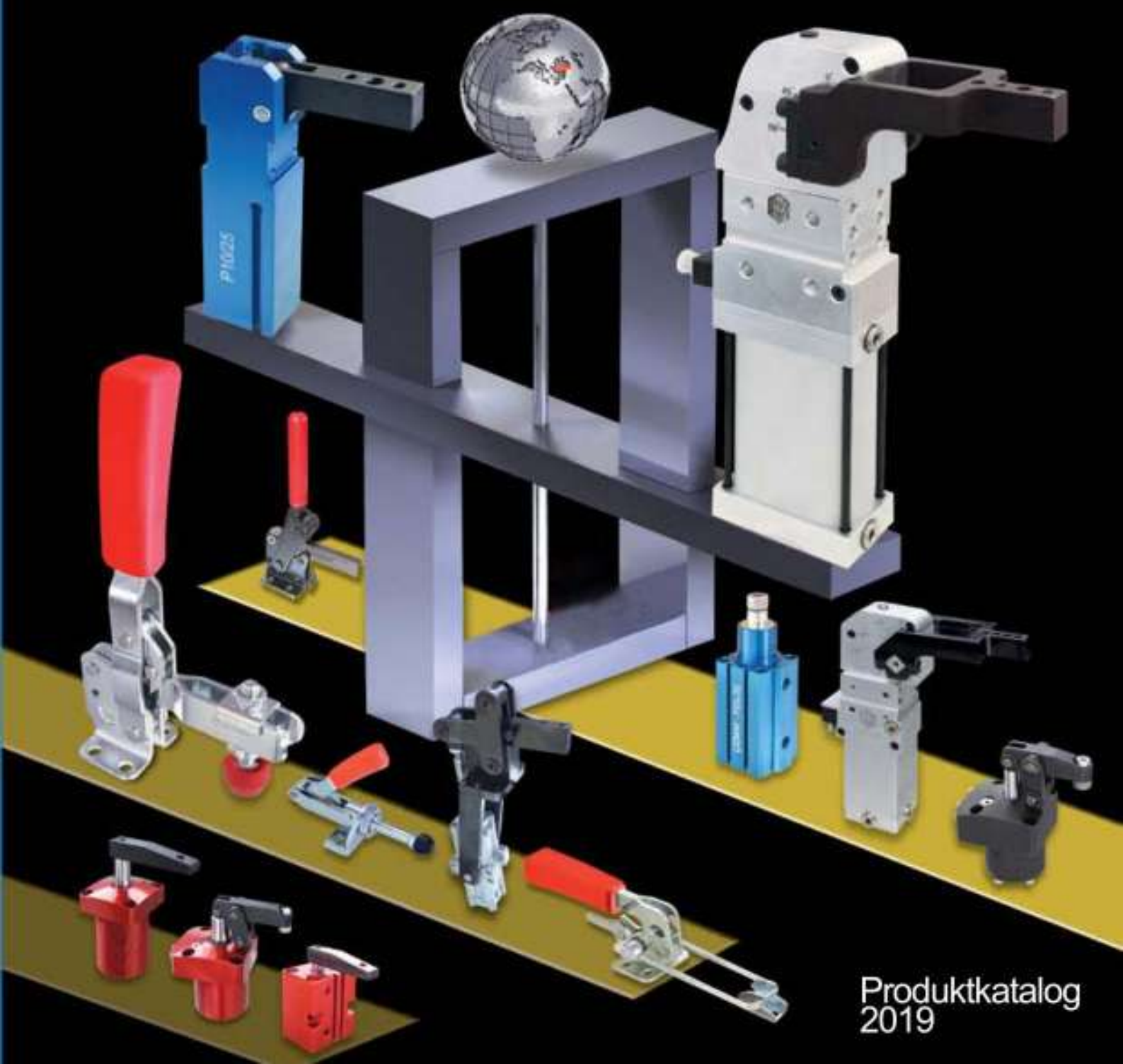









H-Serie Hydraulische Spannelemente





Inhaltsverzeichnis / index

Seite / Page

Mechanisch / Mechanical M-Serie / M Series	 <p>Senkrecht- und Waagrechtspanner <i>vertical and horizontal acting toggle clamps</i></p>	4-14
	 <p>Modulspanner <i>modular toggle clamps</i></p>	14-19
	 <p>Verschlussspanner/Bügelspanner <i>hook type toggle clamps</i></p>	20-25
	 <p>Spannverschlüsse <i>light duty toggle clamps</i></p>	26-28
	 <p>Schubstangenspanner <i>push-pull type toggle clamps</i></p>	29-38
	 <p>Schnellspanner mit Sicherheitsverriegelung <i>toggle clamp with release lever</i></p>	39-46
	 <p>Schnellspanner schwarze Ausführung <i>black type toggle clamps</i></p>	47-48
Pneumatik / Pneumatic P-Serie / P Series	 <p>Schnellspanner aus rostfreiem Stahl <i>stainless steel toggle clamps</i></p>	49-52
	 <p>Pneumatische Spanntechnik <i>pneumatic and toggle clamps</i></p>	53-69
Hydraulik / Hydraulic H-Serie / H Series	<p>★ Neue Baureihen folgen in Kürze !</p>  <p>Hydraulisch Spanntechnik <i>hydraulic and toggle clamps</i></p>	70
Zubehör / Accessories MS-Serie / MS Series	 <p>Schnellspanner-ZUBEHÖR <i>accessories for toggle clamps</i></p>	71-81

Richtige Produkte für eine perfekten Lösung !

Schnellspanner von DESETEC...die richtige Wahl für die richtige Lösung !
toggle clamps..

Ergonomischer, ölbeständiger,
robuster Handgriff

Qualitätsstahl, verzinkt und
galvanisiert

Mechanik mit preväntiver
Funktion zur Erhöhung der
Bediener-Sicherheit

Andrückschraube mit Mutter und Scheibe
(Festigkeitsklasse 8.8)

Nieten aus nicht rostendem Stahl,
gehärtete Lagerbuchsen,
gefettete Gelenk- und Lagerstellen

Hochwertiger Gummi-Druckstück bildet
mit der Andrückschraube eine gesamte
Einheit , öl- und hitzebeständig

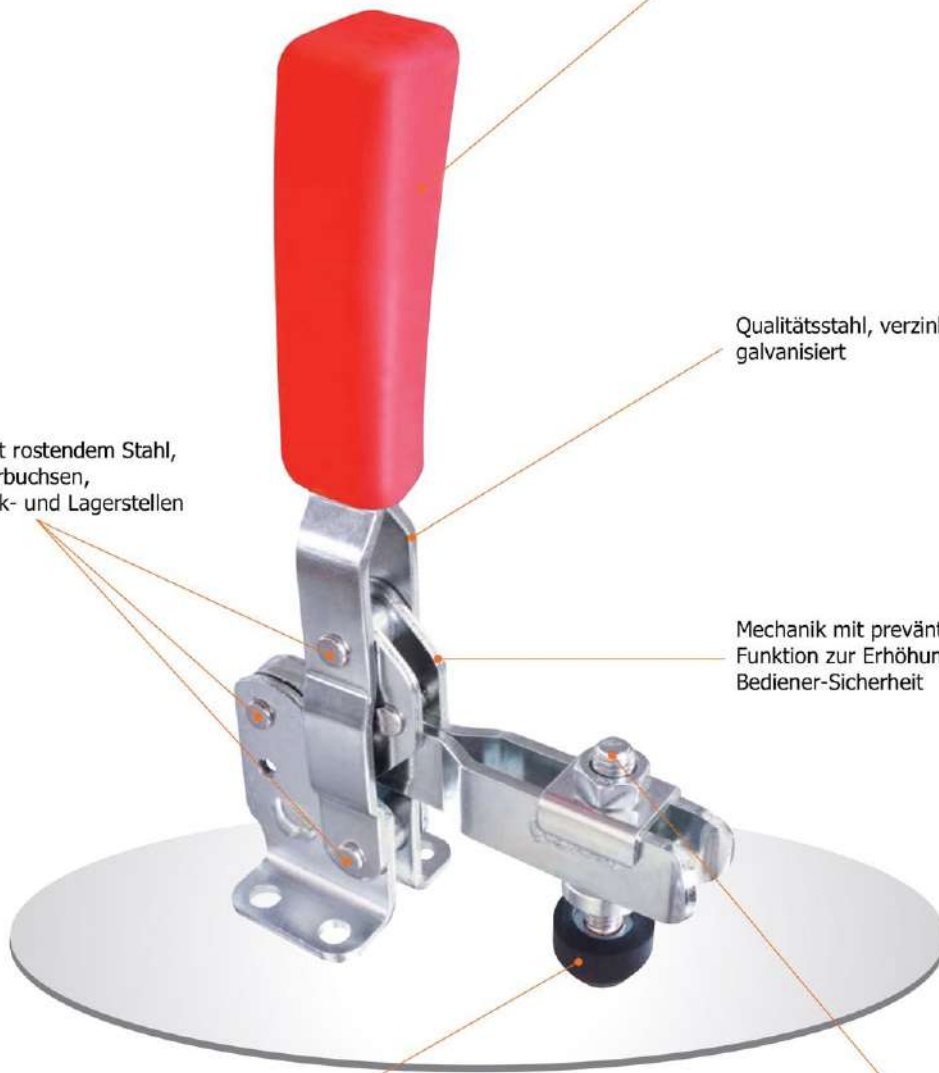

ANWENDUNGSBEISPIELE....

various applications ..fixture applications..

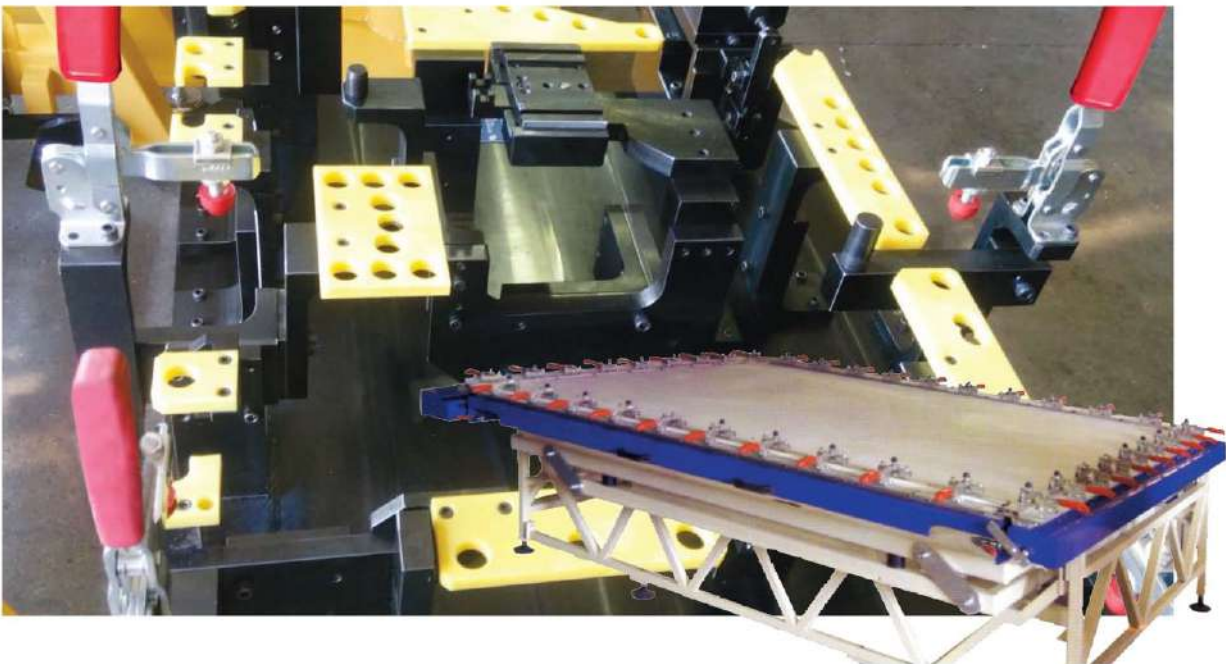
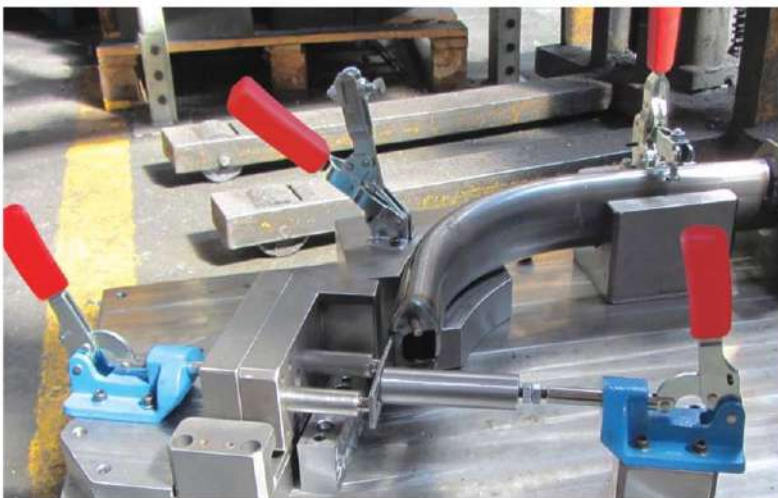

M10 Senkrechtspanner-Vertikalspanner waagrechter Fuß

M10





Vertical acting toggle clamps

Zinc plated, with red oil resistant plastic handles, bushes case hardened and greased, supplied complete with clamping screw and rubber nose.



Size	a	b	c	d	e	f	g	h	i	k	l	m	n	p	q	∅
0	5	34	13.5	4.5	16	10	8.5	17	8	4.5	-	25.5	-	-	10	88°
1	5.5	41	16	4.5	19	11	26.5	19.5	10	5.5	-	-	-	-	12	88°
2	6.2	51	20	5.3	24	10	23	26	12	6	11	30	26	3	13	100°
3	8.5	72	20	7	29	27	-	36	18	7.5	-	32	-	-	16	105°
4	9	101	34.5	8.5	61	30	34	48	20	9.25	17	45	-	-	22	105°
5	14	137	45	8.5	88	40	45	55	25	10.5	25	50	45	5	31.5	115°
6	14	165	50	10.5	90	55	-	70	30	13	-	55	-	-	35	115°



Size	F1 (kN)	F2 (kN)			hw		
0	0.5	0.7	90	50	-3 ÷ 4	M4 x 25	50
1	0.8	1.1	105	60	-4 ÷ 3	M5 x 30	114
2	1.0	1.2	140	76	-3 ÷ 6	M6 x 35	178
3	1.8	2.5	200	105	0 ÷ 12	M8 x 45	400
4	2.0	3.0	230	140	-8 ÷ 21	M8 x 65	740
5	3.0	5.0	265	190	10 ÷ 34	M12 x 80	1500
6	3.5	5.5	300	230	2 ÷ 57	M12 x 110	2160

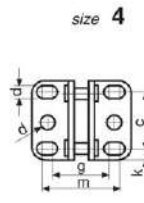
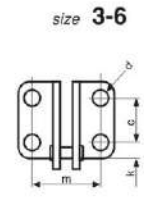
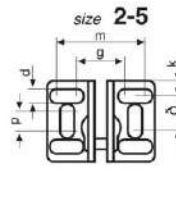
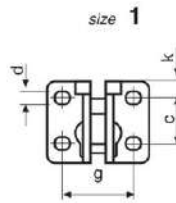
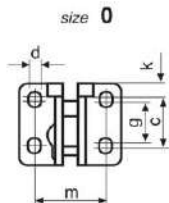
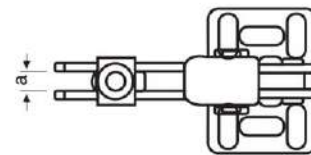
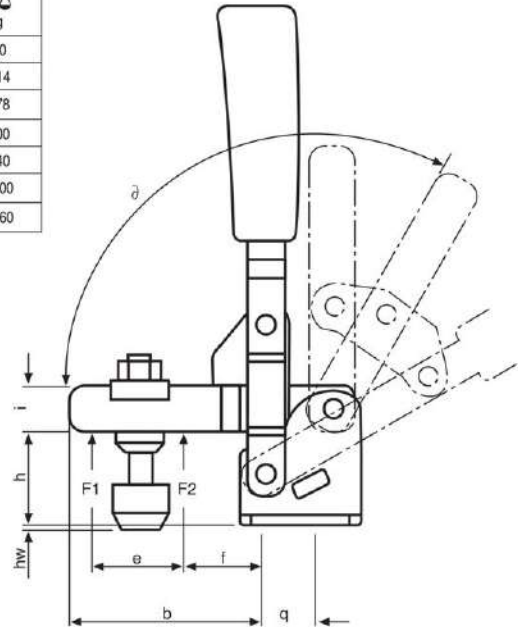

M11 Senkrechtspanner-Vertikalspanner senkrechter Fuß

M11

Vertical acting toggle clamps
with open clamping arm and vertical base.
Galvanized and passivated. Rivets of stainless steel running in case hardened
bushing, with bearing spots greased.
Ergonomic handle of red high quality oil-resistant plastic. Supplied complete
with tempered, galvanized clamping screw no.802

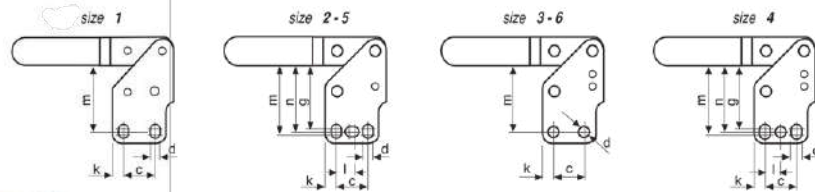
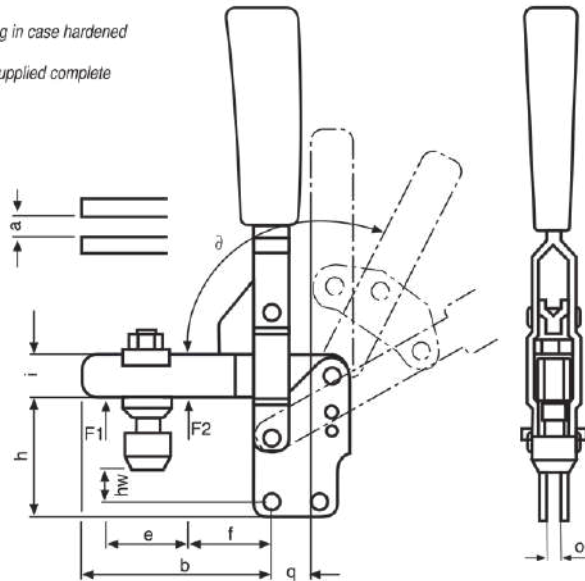
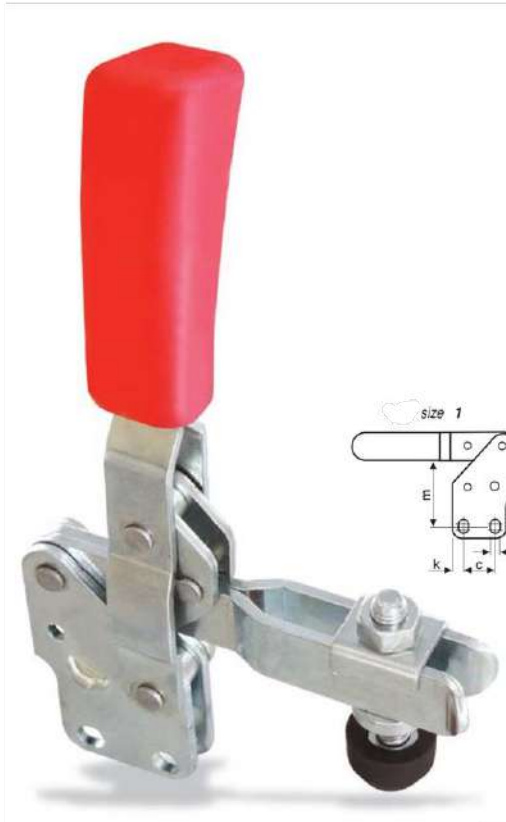

Size	F1 (kN)	F2 (kN)			hw		
1	0.8	1.1	117	60	2 ± 9	M5 x 30	114
2	0.8	1.2	153	76	5 ± 14	M6 x 35	178
3	1.8	2.5	210	105	8 ± 20	M8 x 45	400
4	2.0	3.0	255	140	5 ± 33	M8 x 65	740
5	3.0	5	323	190	22 ± 45	M12 x 80	1500
6	3.5	5.5	335	230	5 ± 57	M12 x 110	2160

Size	a	b	c	d	e	f	g	h	i	k	l	m	n	o	q	∠
1	5.5	41	16	4.5	19	14	-	31	10	5.5	-	27	-	5	12	88°
2	6.2	51	20	5.3	24	10	30	38	12	5	12	33	31.5	5	13	100°
3	8.5	72	20	7	29	27	-	50	18	7.5	-	44	-	6	16	105°
4	9	101	34.5	8.5	61	30	56.5	71.5	20	9.25	17	60	59	8	22	105°
5	14	137	45	8.5	88	40	65.5	78	25	10.5	25	68	67	10	31.5	115°
6	14	167	50	10.5	90	55	-	106	30	12.5	-	88.5	-	10	35	115°

M12 Senkrechtspanner-Vertikalspanner Winkelfuß

M12

Vertical acting toggle clamps
with open clamping arm and vertical base.
Galvanized and passivated. Rivets of stainless steel running in case hardened bushing, with bearing spots greased. Ergonomic handle of red high quality oil-resistant plastic. Supplied complete with tempered, galvanized clamping screw no.803

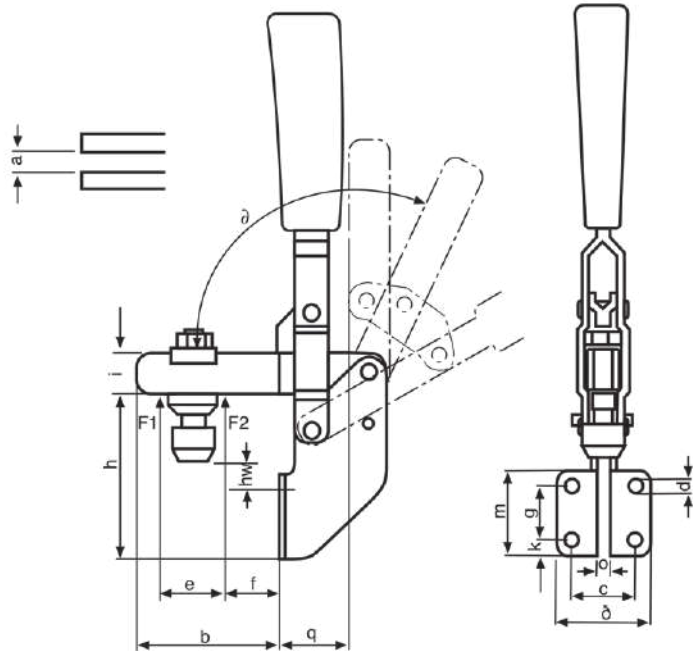

Size	F1 (kN)	F2 (kN)			hw		
1	0.8	1.1	132	60	-1.5 ± 5.5	M5 x 30	125
2	1.0	1.2	135	76	2 ± 11	M6 x 35	220
3	1.8	2.5	235	105	6 ± 18	M8 x 45	470
4	2	3	270	141	11 ± 40	M8 x 65	740

Size	a	b	c	d	e	f	g	h	i	k	l	m	n	o	q	∅
1	5	38	25	4.5	19	8	14.5	45	10	5.5	35.5	25	6	16	105 ^o	
2	6	40	25.5	6	25	9	22	61	12	6	37	34	5	24	105 ^o	
3	8.2	58	31.5	7.5	30	14	24	73	18	7	45	39	6	31	105 ^o	
4	10	77.5	42	8.5	35	19	28	77	20	7	60	42	8	35	105 ^o	





M10L Senkrechtspanner- massiver Haltearm-waagrechter Fuß

M10L

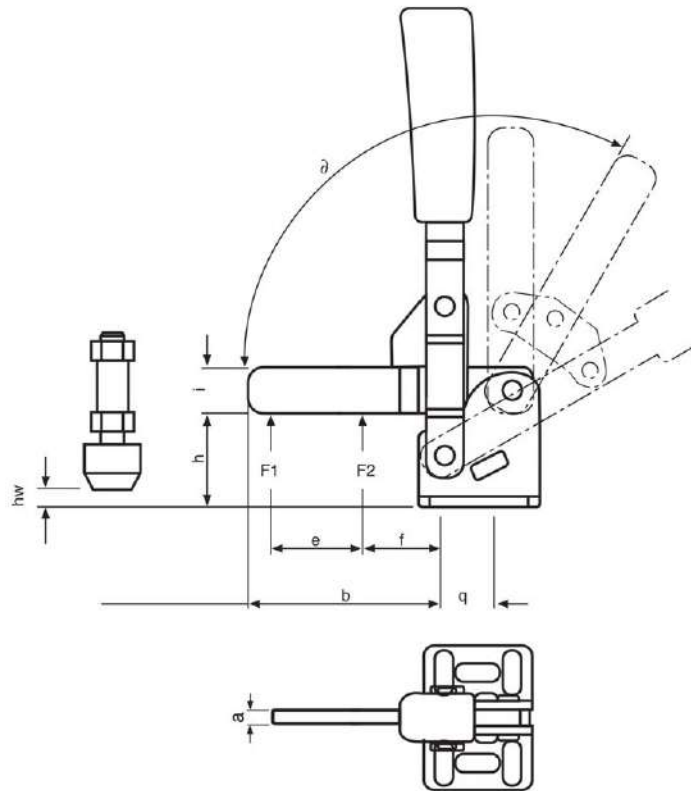
Vertical acting toggle clamps with solid arm

Zinc plated, with red oil resistant plastic handles, bushes case hardened and greased, supplied complete with clamping screw and rubber nose.



Size	F1 (kN)	F2 (kN)			hw		
2	1.0	1.2	140	76	-3 ÷ 6	M6 x 35	178
3	1.8	2.5	200	105	0 ÷ 12	M8 x 45	400
4	2.0	3.0	230	140	-8 ÷ 21	M8 x 65	740
5	3.0	5.0	265	190	10 ÷ 34	M12 x 80	1500

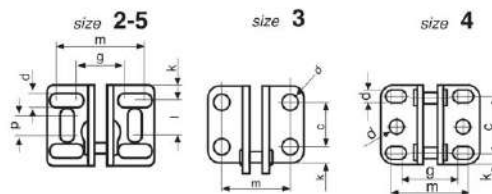

Size	a	b	c	d	e	f	g	h	i	k	l	m	n	p	q	θ
2	5	51	20	5.3	24	10	23	26	12	6	11	30	26	3	13	100°
3	6	72	20	7	29	27	-	36	18	7.5	-	32	-	-	16	105°
4	8	101	34.5	8.5	61	30	34	48	20	9.25	17	45	-	-	22	105°
5	10	137	45	8.5	88	40	45	55	25	10.5	25	50	45	5	31.5	115°

M11L Senkrechtspanner- massiver Haltearm-senkrechter Fuß

M11L

Vertical acting toggle clamps with solid arm with open clamping arm and vertical base. Galvanized and passivated. Rivets of stainless steel running in case hardened bushing, with bearing spots greased. Ergonomic handle of red high quality oil-resistant plastic. Supplied complete with tempered, galvanized clamping screw

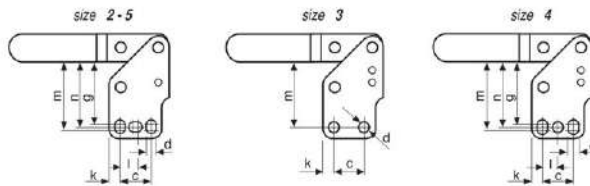
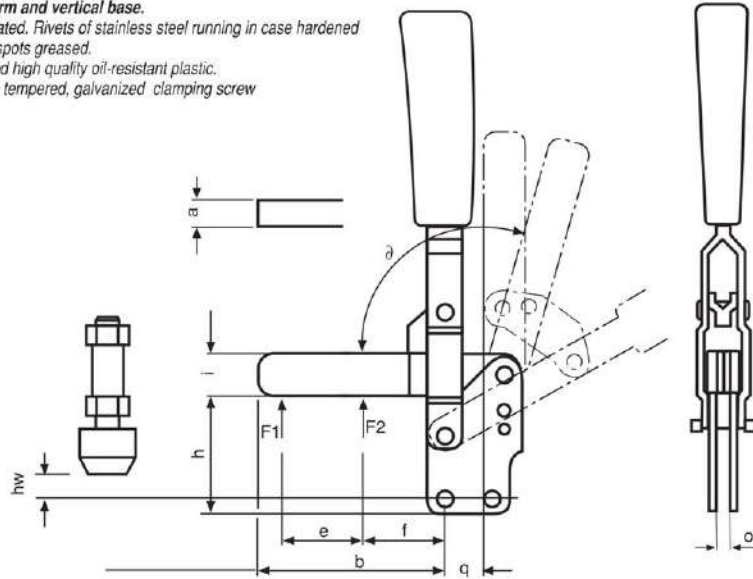
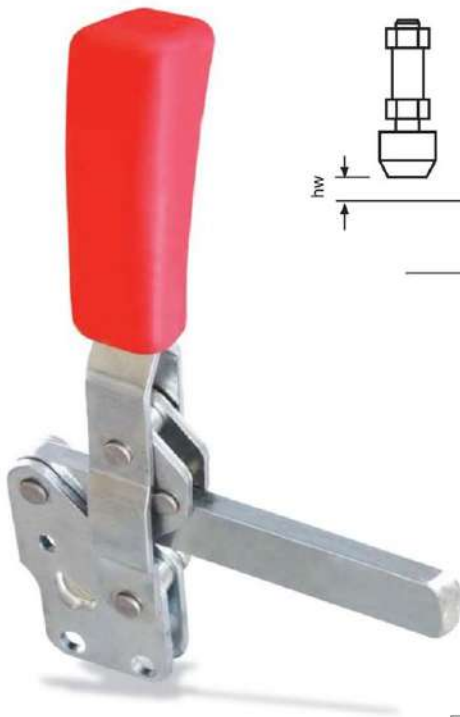

Size	F1 (kN)	F2 (kN)			hw		
2	0.8	1.2	153	76	5 + 14	M6 x 35	178
3	1.8	2.5	210	105	8 + 20	M8 x 45	400
4	2.0	3.0	255	140	5 + 33	M8 x 65	740
5	3.0	5	323	190	22 + 45	M12 x 80	1500

Size	a	b	c	d	e	f	g	h	i	k	l	m	n	o	q	\bar{d}
2	5	51	20	5.3	24	10	30	38	12	5	12	33	31.5	5	13	100°
3	6	72	20	7	29	27	-	50	18	7.5	-	44	-	6	16	105°
4	8	101	34.5	8.5	61	30	56.5	71.5	20	9.25	17	60	59	8	22	105°
5	10	137	45	8.5	88	40	65.5	78	25	10.5	25	68	67	10	31.5	115°

M12L Senkrechtspanner- massiver Haltearm-Winkelfuß

M12L

Vertical acting toggle clamps with solid arm with open clamping arm and vertical base.

Galvanized and passivated. Rivets of stainless steel running in case hardened bushing, with bearing spots greased. Ergonomic handle of red high quality oil-resistant plastic. Supplied complete with tempered, galvanized clamping screw

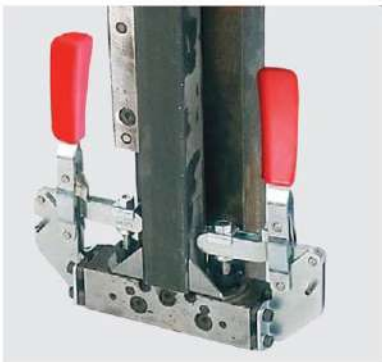
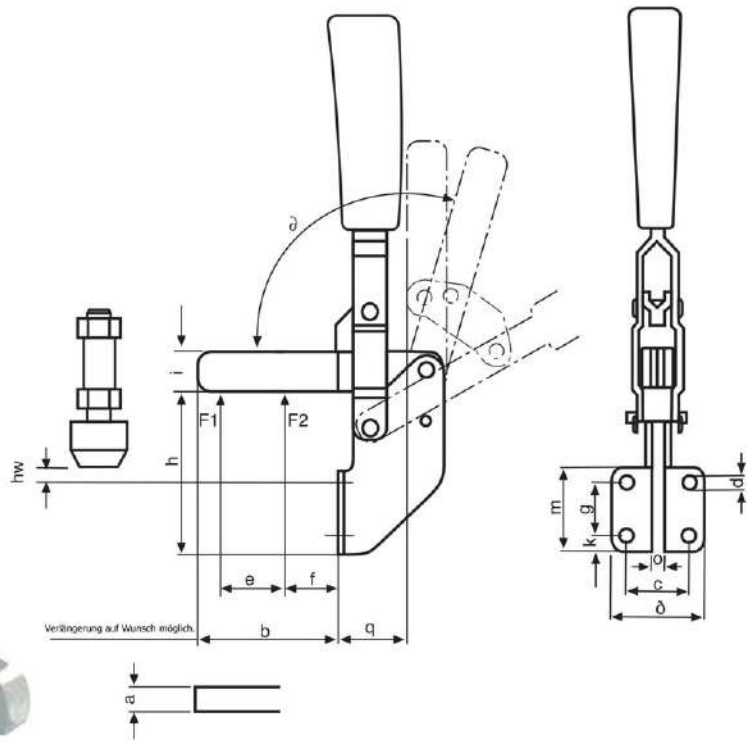

Size	F1 (kN)	F2 (kN)			hw		
2	1.0	1.2	135	76	2 ÷ 11	M6 x 35	220
3	1.8	2.5	235	105	6 ÷ 18	M8 x 45	470
4	2	3	270	141	11 ÷ 40	M8 x 65	740

Size	a	b	c	d	e	f	g	h	i	k	l	m	o	q	∠
2	5	40	25.5	6	25	9	22	61	12	6	37	34	5	24	105°
3	6	58	31.5	7.5	30	14	24	73	18	7	45	39	6	31	105°
4	8	77.5	42	8.5	35	19	28	77	20	7	60	42	8	35	105°

Anwendungsbeispiel



M20 Waagrechtspanner-Horizontalspanner waagrechtter Fuß

M20

Horizontal acting toggle clamps
Zinc plated; with red oil resistant plastic handle.
Bushes case-hardened and greased.
Supplied complete with clamping screw and rubber nose.



Size	F1 (kN)	F2 (kN)			hw		
0	0.25	0.40	23	85	-5 ± 2	M4 x 25	37
1	0.80	1.10	30	128	-4 ± 3	M5 x 30	112
2	1.00	1.20	44	158	-3 ± 6	M6 x 35	182
3	1.80	2.50	48	221	-1 ± 11	M8 x 45	340
4	2.00	3.00	74	293	-6 ± 23	M8 x 65	700
5	3.00	5.00	71	330	-1 ± 25	M8 x 65	1170

Size	a	b	c	d	e	f	g	h	i	k	l	m	n	q
0	4	25	16	4.1	11	10	11	15	7	4	-	16	-	2
1	5	40	24	5.2	26	11	19.5	20	10	5.5	-	23	20.5	5
2	6	51	26	5.4	28	12	-	30	13.5	6	13	30	22	6
3	8	72	28	6.5	44	22	21.5	33	15	7	-	25.5	21	8
4	10	111	41	8.5	66	34	-	44	20	8	20	44.5	29	8
5	12	120	43.5	8.5	78	30	-	46	25	-	26	-	-	10

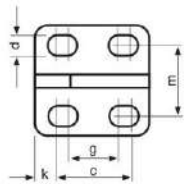

size 0

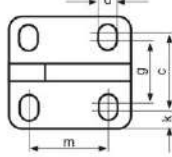

size 1

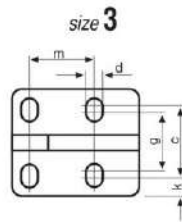

size 3

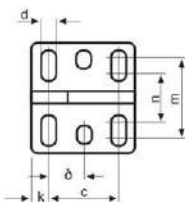

size 2-4

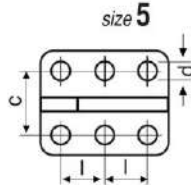

size 5

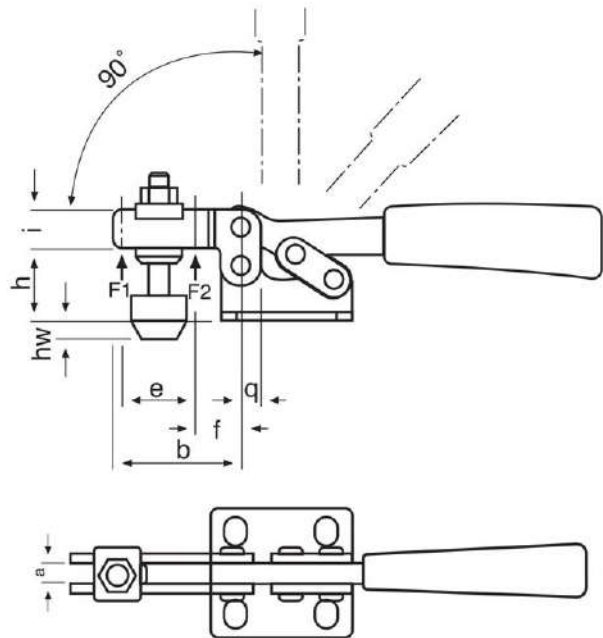

M21 Waagrechtspanner-Horizontalspanner senkrechter Fuß

M21

Horizontal acting toggle clamps

Zinc plated, with red oil resistant plastic handles, bushes case hardened and greased, supplied complete with clamping screw and rubber nose.

Size	F1 (kN)	F2 (kN)			hw		
0	0.25	0.40	32	85	0 + 7	M4 x 25	37
1	0.8	1.10	42	128	3 + 10	M5 x 30	112
2	1.0	1.20	59	158	7 + 16	M6 x 35	182
3	1.80	2.50	63	221	8 + 20	M8 x 45	340
4	2.00	3.00	96	293	9 + 38	M8 x 65	700
5	3.00	5.00	93	330	13 + 37	M8 x 65	1170

Size	a	b	c	d	e	f	g	h	i	k	l	m	n	o	q
0	4	25	16	4.1	11	10	11	24	7	4	-	21	-	3	2
1	5	40	23	5.2	26	11	24	32	10	5.5	-	28	25	5	5
2	6	51	28	5.4	28	12	-	46	13.5	6	13	43	38	5	6
3	8	72	25.5	6.5	44	22	-	49	15	7	-	43	38	6	8
4	10	111	41	8.5	66	34	-	66	20	8	20.5	60	53	8	8
5	12	120	-	8.5	78	10	10	68	25	7	26	60	12	22	23

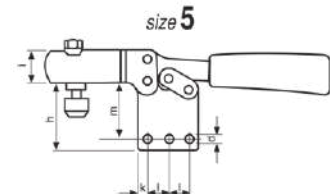
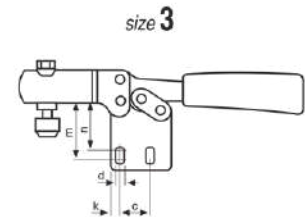
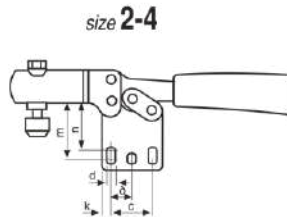
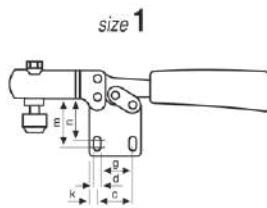
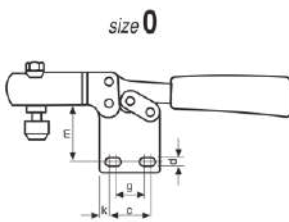
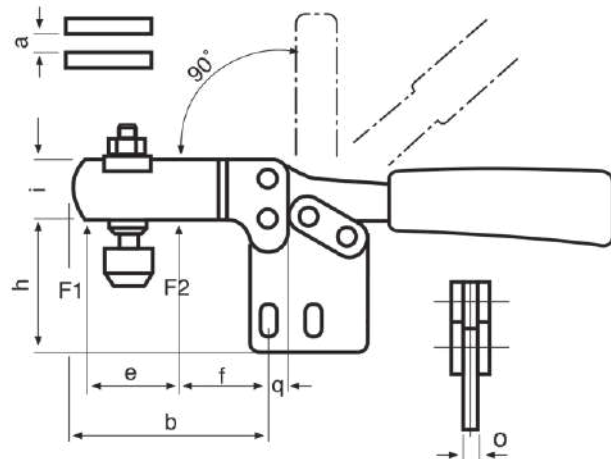

M22 Waagrechtspanner-Horizontalspanner Winkelfuß

M22

Horizontal acting toggle clamps

Zinc plated, with red oil resistant plastic handles, bushes case hardened and greased, supplied complete with clamping screw and rubber nose.

Size	F1 (kN)	F2 (kN)			hw		
1	0.8	1.1	68	128	3÷10	M5 x 30	170
2	1.0	1.2	94	155	20÷29	M6 x 35	250
3	1.8	2.5	86	221	6÷18	M8 x 45	400
4	2	3	97	261	12÷40	M8 x 65	750

Size	a	b	c	c1	d	e	f	g	h	i	k	m	n	o	p	q
1	5	30.5	13.5	19.5	5.2	26	4	-	58	10	6	28	-	-	31	15
2	6	38	18.5	-	5.5	26	10	27	80.5	13.5	6	32	9.5	19	40.5	17
3	8	58	24	-	6.5	42	8	28	72	15	7	38	12	21	23	41
4	10	91	30.5	-	8.5	52	11	37.5	93.5	20	7.5	77	16	30.5	56	28

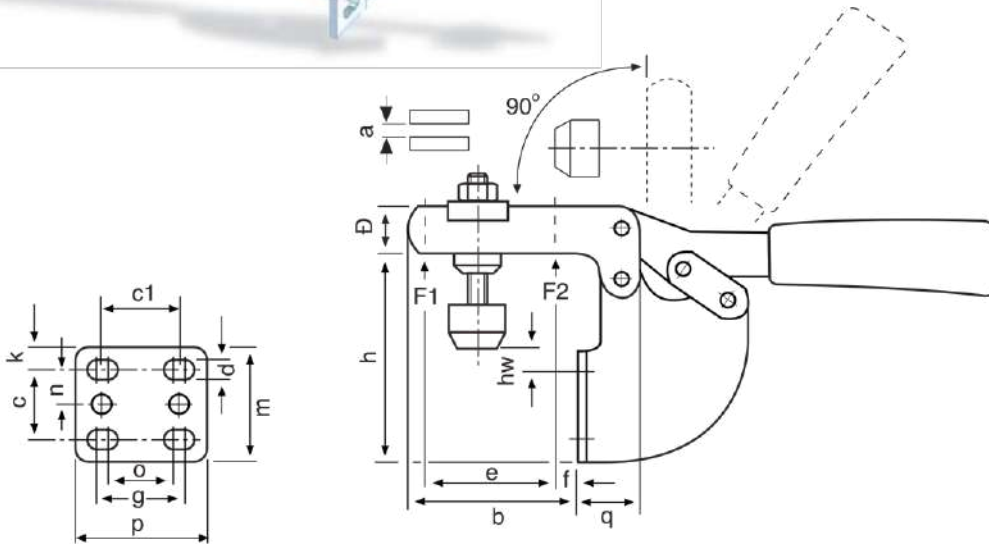



M25 Waagrecht- und Senkrechtspanner

M25

Horizontal and vertical acting toggle clamps

Zinc plated; with red oil resistant plastic handle. Bushes case-hardened and greased.
 Supplied complete with clamping screw and rubber nose.



Size	F1 (kN)	F2 (kN)		 g
5	2.50	5.00	M8 x 65	1.560

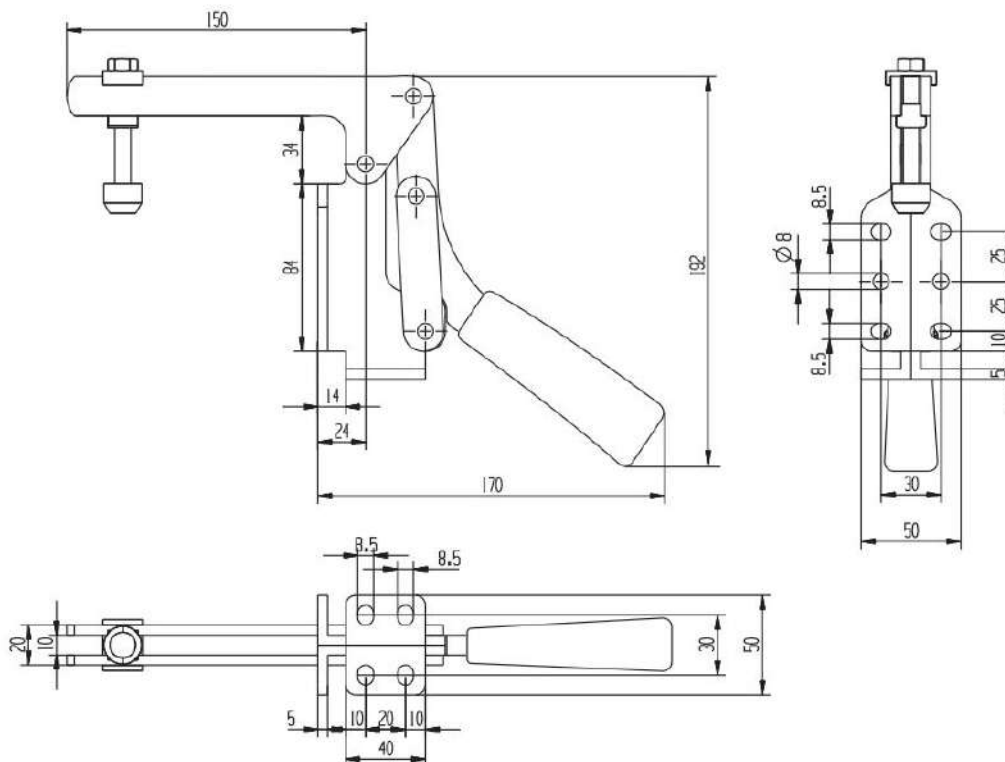

M30 Modulspanner-schweisbar-schwenkbarer Fuß

M30

Modular Toggle Clamps
with swivelling foot, welding version

Mechanism can be welded at an angle to its support. Reamed and case-hardened bearing bushes. Hardened, ground and permanently-lubricated pins. Clamp nuts on lever arm to vary friction in movement. Material: Steel, blued. Lever arm made of cast steel, blued.

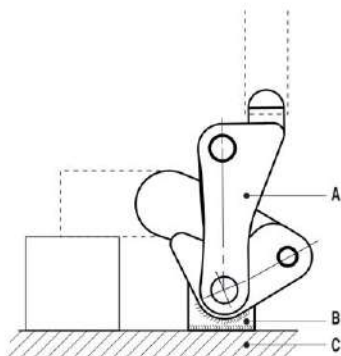
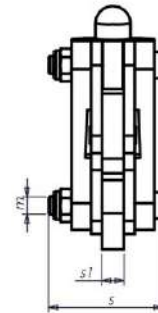
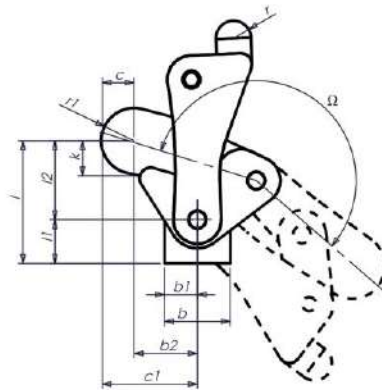
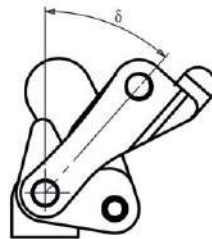

Anleitung Schweissposition :
Teil "A" wird an Teil "B" geschweisst.
Teil "B" wird an "C" geschweisst.

Size	F1 (kN)			L g
4	7.0	112	82	855
6	11.0	145	105	1600

Size	b	b1	b2	c	c1	k	l	l1	l2	m	r	r1	s	s1	Ω	∂	δ
4	30	15	10	16	41	12	58	20	38	M8	8	15	52	10	200°	70°	40°
6	38	18	12	20	55	16	78	28	50	M10	11	18	60	12	200°	70°	40°

M32 Modulspanner-schweisbar-senkrechter Fuß

M32

Modular Toggle Clamps
with svERTICAL foot, welding version

Mechanism can be welded at an angle to it's support. Reamed and case-hardened bearing bushes. Hardened, ground and permanently-lubricated pins. Clamp nuts on lever arm to vary friction in movement. Material: Steel, blued. Lever arm made of cast steel, blued.

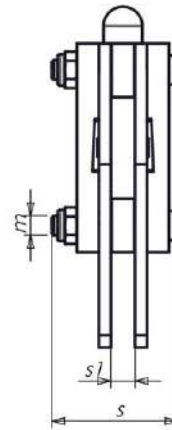
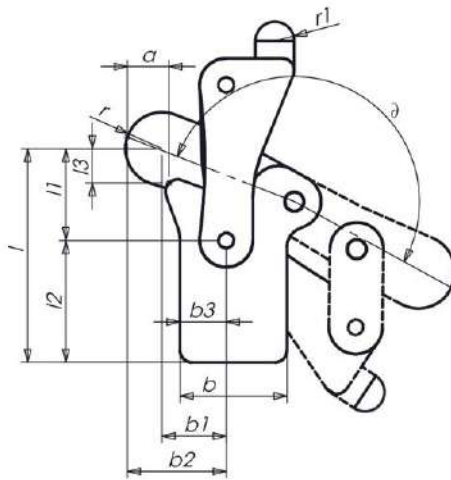

Size	F1 (kN)			
4	7.0	112	82	970
6	11.0	182	106	1750

Size	a	b	b1	b2	b3	l	l1	l2	l3	m	r	r1	s	s1	α
4	16	44	26	41	19	88	38	50	12	M8	15	8	52	10	190°
6	20	55	36	55	28	114	50	64	16	M10	18	11	60	12	190°

MS30 Modulspanner - ZUBEHÖR

MS30/16

Hand Grip
Red, oil-resitant plastic



Size	d4 x h4	g
4	18 x 90	20
6	22 x 100	28

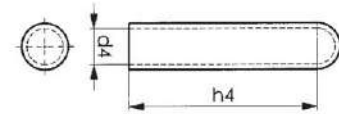

MS30/17

Lever Arm Tube - Short Type
For welding, chamfered to protect operator's hands.
Material steel, blued



Size	d2 x h2	g
4	18 x 95	104
6	22 x 105	150

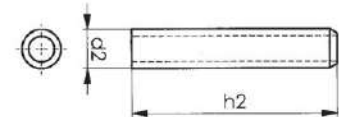

MS30/18

Lever Arm Tube - Long Type
For welding, chamfered to protect operator's hands.
Material steel, blued



Size	d2 x h2	g
4	18 x 120	132
6	22 x 150	210

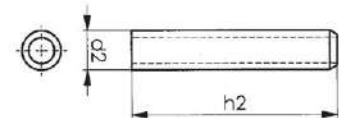

MS30/20

Clamping Arm Extension
For welding, slotted. Material steel, blued



Size	b x h x t	g
4	48 x 25 x 20	210
6	60 x 30 x 25	390

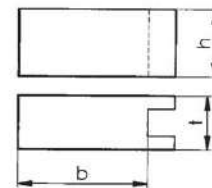

MS30/30

Clamping Screw Holder
For welding, thick-walled. Material steel, blued



Size	d1 x h1	g
4	12.1 x 24	50
6	12.1 x 30	65

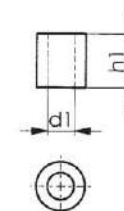

MS30/10

Baseplate
For welding, with mounting holes. Material steel, blued



Size	c	c3	d	m	l	s	c3	g
4	25	40	6.5	35	50	8	40	112
6	40	60	8.5	30	50	8	60	170

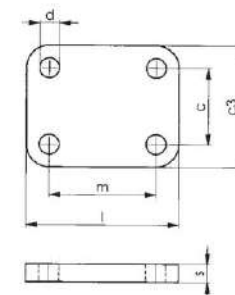

M33 Schwerer Senkrechtspanner – schwere Ausführung

M33

Heavy vertical acting toggle clamps
with horizontal base

Reamed and case-hardened bearing bushes. Hardened, ground and permanently-lubricated pins.
Clamp nuts on lever arm to vary friction in movement.
Materials, steel, blued.
Lever arm made of cast steel, blued. Handle of red, oil-resistant plastic.
Complete with tempered, galvanized clamping screw.

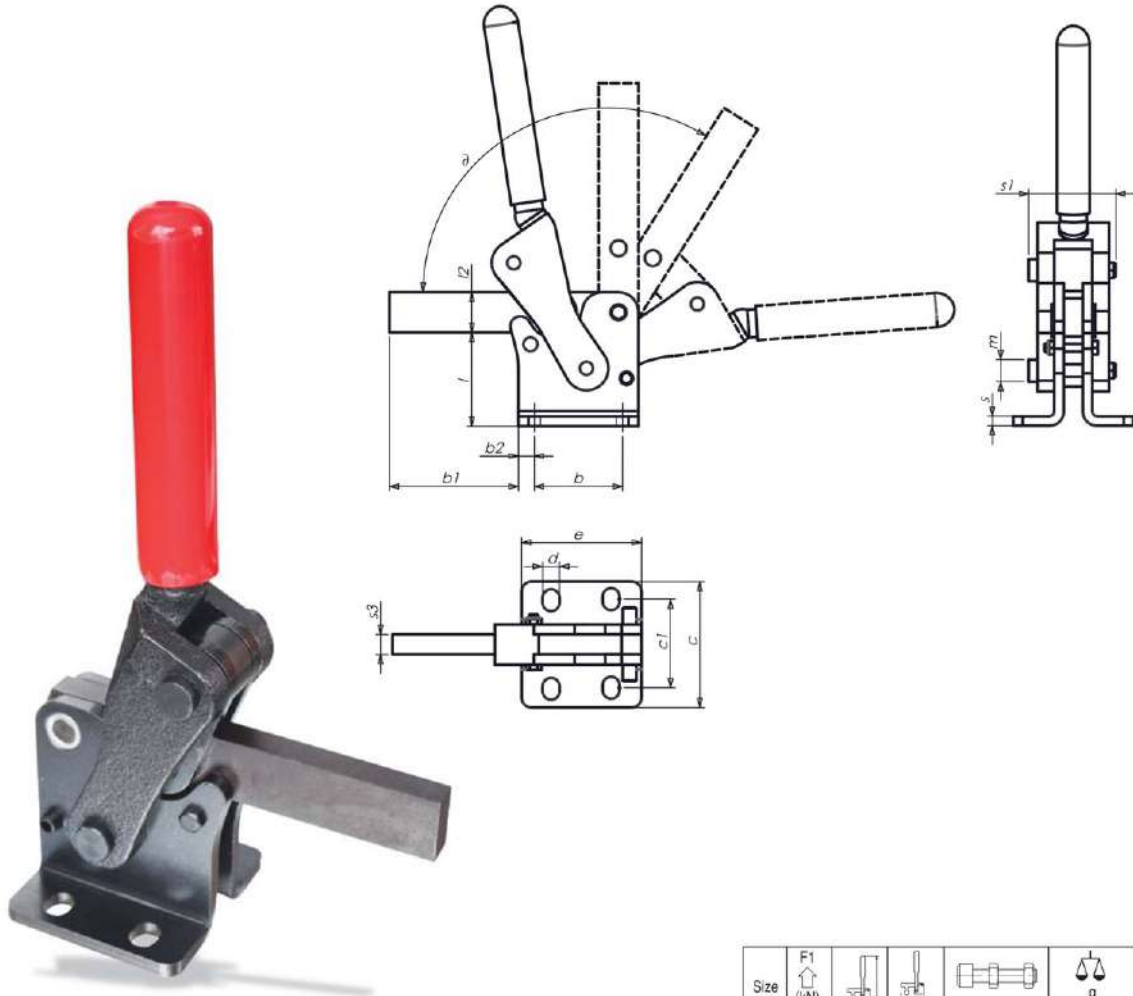

Size	F1 (kN)				
4	7.0	86	148	M12 x 80	970
6	10.0	106	182	M12 x 110	1750

/ Size	b	b1	b2	c	c1	d	e	l	l2	m	s	s1	s3	∅
4	30	70	15	63	44	8.5	60	47	20	M8	5	46	10	120°
6	45	95	15	75	52	10.5	75	67	25	M10	5	60	12	120°

M34 Schwerer Senkrechtspanner – schwere Ausführung

M34

Heavy vertical acting toggle clamps with vertical base and mounting holes.
Reamed and case-hardened bearing bushes. Hardened, ground and permanently-lubricated pins.
Clamp nuts on lever arm to vary friction in movement.
Materials, steel, blued.
Lever arm made of cast steel, blued. Handle of red, oil-resistant plastic.
Complete with tempered, galvanized clamping screw.

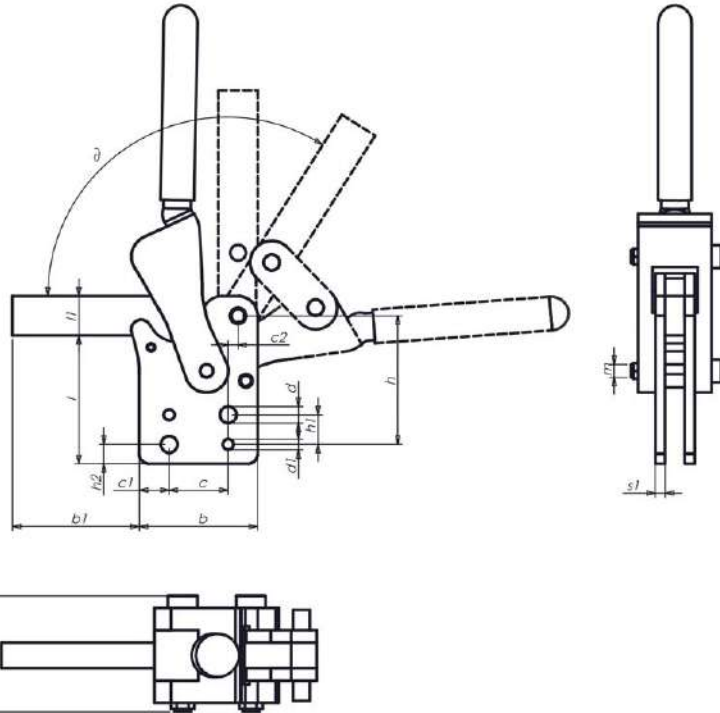
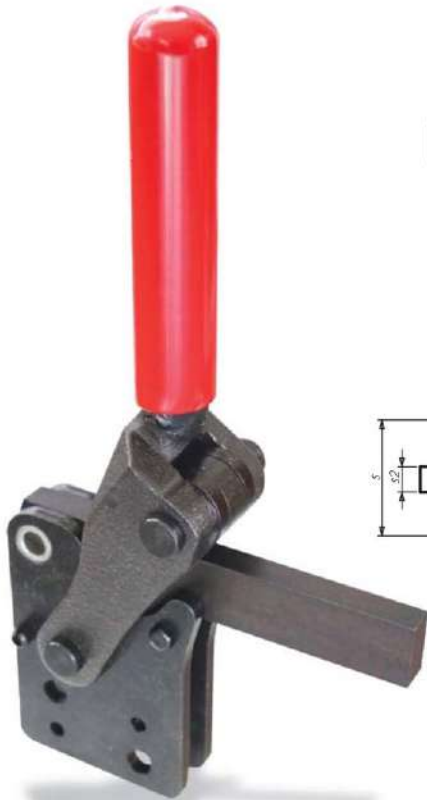

Size	F1 (kN)				
4	7.0	86	148	M12 x 80	970
6	10.0	106	182	M12 x 110	1750

Size	b	b1	c	c1	d	d1	h	h1	h2	l	l1	m	s	s1	s2	α
4	60	86	30	15	8.5	5.5	65	15	10	52	20	M8	52	5	10	120°
6	75	106	45	15	10.5	7.5	87.5	20	15	72	25	M10	60	5	12	120°

M40Y Verschlusspanner/Bügelspanner horizontal

M40Y

Hook type toggle clamps - horizontal
Galvanized and passivated.
Bushes case hardened and greased; rivets of stainless steel.
Hook and clamping sleeve tempered.
With traditional red oil-resistant plastic handle.

Size	← (kN)	Ayar Aralık Adjustm. distance (mm)			
1	1	26	28	60	90
2	1.4	32	43	70	110
3	2.5	42	64	102	300
4	4.5	55	84	140	710



Size	b	c	d	e	f	g	h	k	l	m	n	s	t
1	30-65	16	3.5	18-28	10	4.5	12	5.5	26.5	21	28	4	18.5
2	42-74	13	4	38-70	11	5.2	12	6.5	26	24	38	6	19
3	53-95	19	6	48-90	14	6.5	19	8	35	32	48	6	25
4	72-127	32	8	65-120	19	8.5	25	9.5	51	45	65	13	36

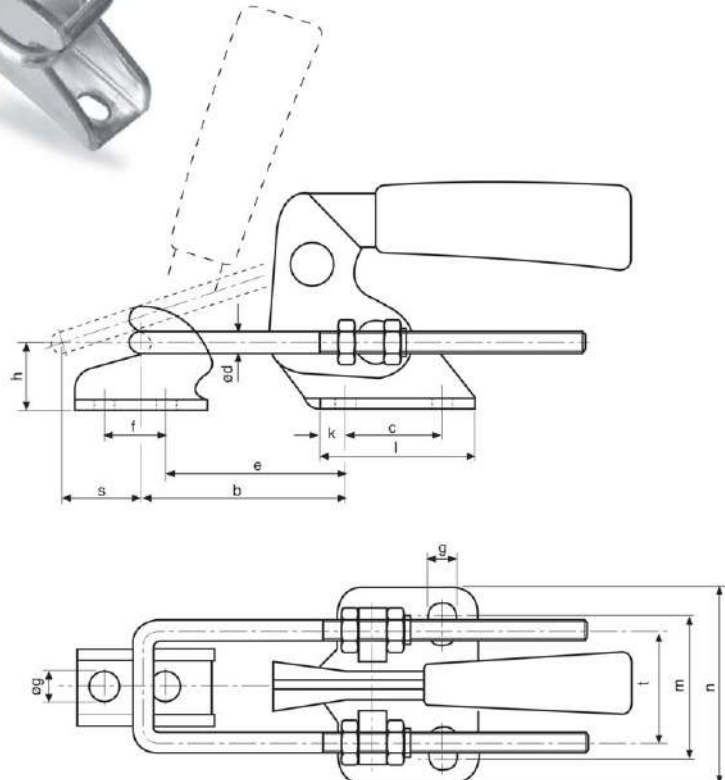



M40D Verschlussspanner/Bügelspanner vertikal

M40D

Hook type toggle clamps - Vertical

Galvanized and passivated.
Bushes case hardened and greased; rivets of stainless steel.
Hook and clamping sleeve tempered.
With traditional red oil-resistant plastic handle.

Size	↓ (kN)	Ayer Araligi Adjustm. distance (mm)			
2	1.6	26	45	100	130
3	3.2	28	68	135	340
4	7	36	90	165	810

Size	B	C	D	D1	E	F	H	H1	H2	K	L1	M	N	P
2	24 - 47	13	5.2	4	5 - 28	11	4.5	47	99	6.8	91 - 158	19.5 - 23.5	38	26
3	33 - 63	19	6.5	6	6.5 - 37	14	6	70	137	8	125 - 195	24.5 - 32.5	48	35
4	43 - 81	32	8.5	8	9 - 47	19	8	94.5	171	9.6	155 - 244	35 - 46	64.5	53.5

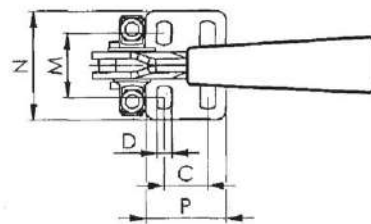
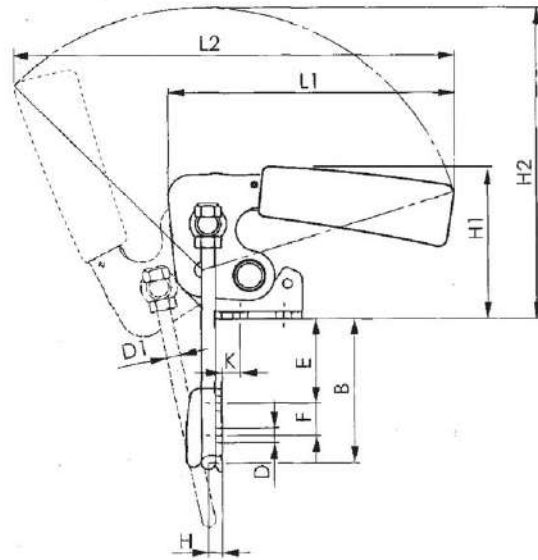

M42 Verschlussspanner/Bügelspanner horizontal

M42

Hook type toggle clamps

Galvanized and passivated.

Bushes case hardened and greased; rivets of stainless steel.

Hook and clamping sleeve tempered.

With traditional red oil-resistant plastic handle.

Size	← (kN)	Ayar Aralığı Adjustm. distance (mm)	⚖ g
3	3.2	26	230
4	10	32	800

Size	A	A1	A2	A3	A4	A5	B	B1	B2	B3	B4	C	C2	C3	øD	øD1	H	L	L1 max	L2	M	S
3	19	40	10.5	6.5	7.5	26	31.5	45	16	25	38	16.5	3	3	6.5	5.3	64	170	90	13	M5	45.5
4	41.5	60	19	9.25	8	41	39	55	28.5	44.5	47.5	25	4	4	8.3	8.3	77	255	136	20	M10	63.5

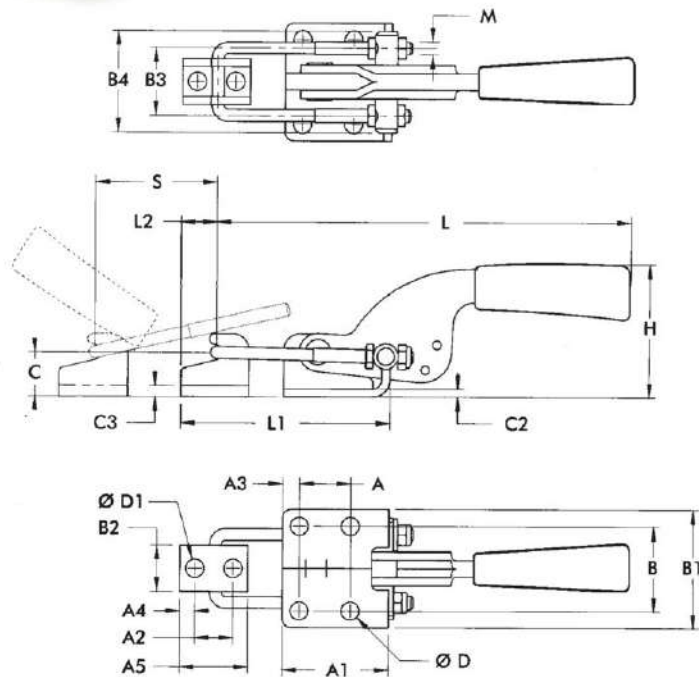

M44 Schwerer Verschlußspanner/Bügelspanner horizontal
M44

Heavy hook type toggle clamp
 for high retaining force.

Pins hardened, ground and permanently lubricated.
 Circlips are used to retain pins in bearing bushes, and to centre the clamping pin.
 Foot, lever arm and catch are made of cast steel and blued.
 Stirrup, pins and nuts are heat-treated zinc-plated.
 Handle grip is red, oil-resistant plastic.



Size	← (kN)	Ayar Aralığı Adjustm. distance (mm)		
4	15	50	90 280	1400 g

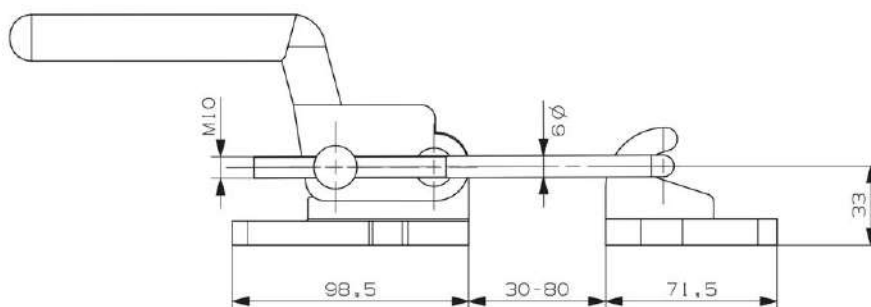
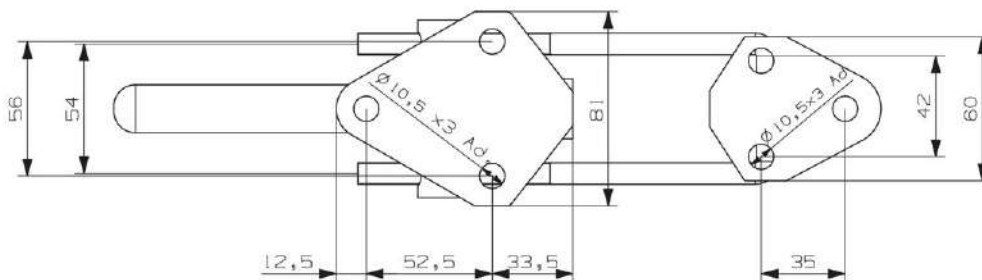

M46 Verschlusspanner-Hakenspanner

M46

Hook type toggle clamps

Galvanized and passivated. Bushes case hardened and greased; rivets of stainless steel.
Hook and clamping sleeve tempered.
With traditional red oil-resistant plastic handle.

Size	b	c	d	e	g	h	k	l	m	n	R	s
1	36-41	19	6	36.5 - 41.5	4.5	24	6.5	33	27-29	41	4.5	45
3	67-79	19	8	74.5 - 86.5	5.5	24	13	41	32-35	43	5.5	98
5	58-70	30	12	58.5 - 70.5	11	49	13	55	56-61	85	8	144



Size	↔ (kN)	Ayar Aralığı Adjustm. distance (mm)	↔	↔	⚖ g
1	2.0	5	33	130	100
3	3.0	12	36	230	300
5	5.0	12	70	310	850



Counter catch

Galvanized and passivated.
Bushes case hardened and greased; rivets of stainless steel.

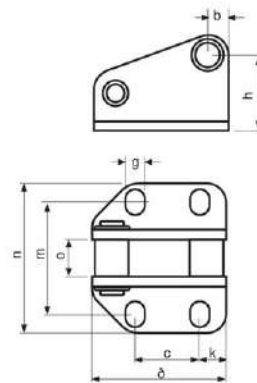
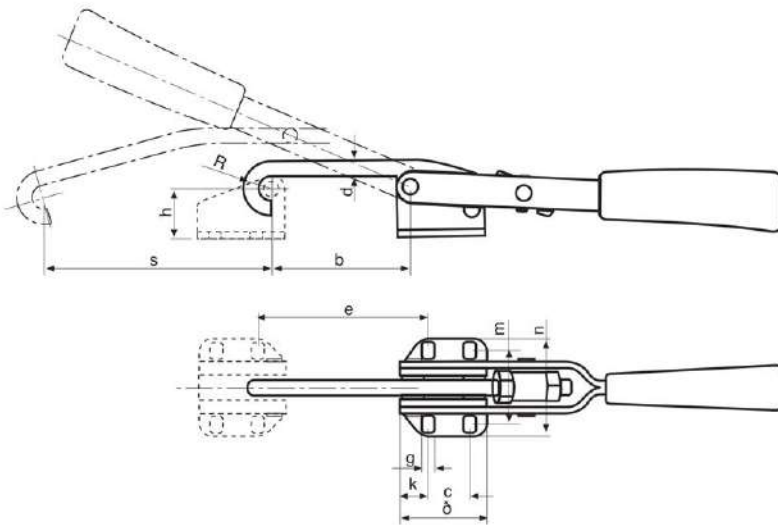

M46K Verschlussspanner-Hakenspanner



M46K

Hook type toggle clamps

Galvanized and passivated.

Bushes case hardened and greased; rivets of stainless steel.

Hook and clamping sleeve tempered. With traditional red oil-resistant plastic handle.

Size	← (kN)	Ayar Araligi Adjustm. distance (mm)			
3	3.0	12	36	230	300

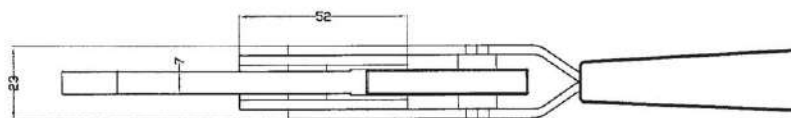
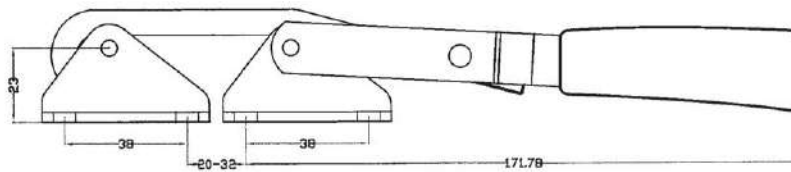
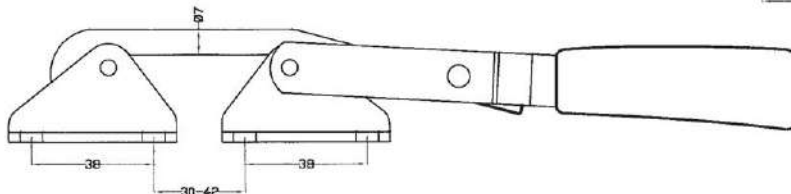
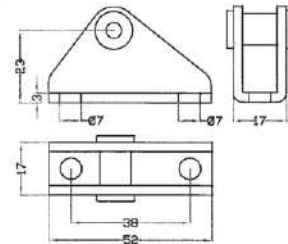

M50/2 Spannerverschluss-einstellbar

M50/2

Light duty toggle clamp

Light duty adjustable draw latch/toggle clamp/under centre fastener with variable overcenter. Features reverse action design. For tension adjustment and fitting tolerance latch has 10mm of screw adjustment.



Optional galvanized and stainless steel

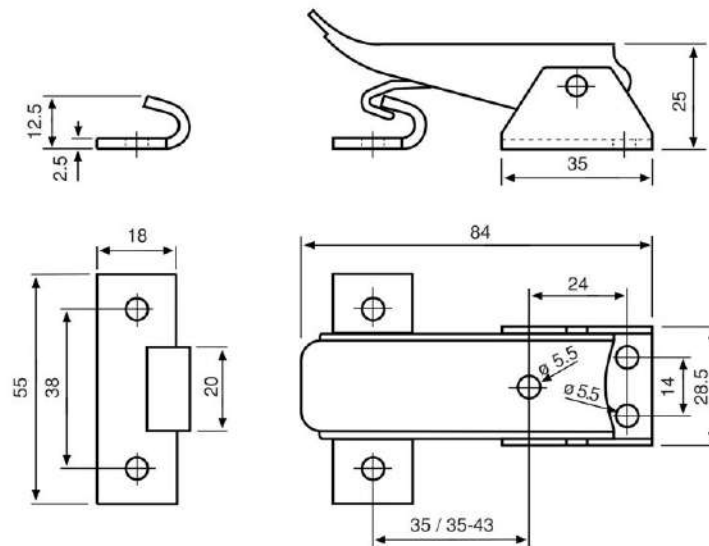

M52 Spannerverschluss-einstellbar

M52

Light duty toggle clamp

Light duty adjustable draw latch/toggle clamp/under centre fastener with variable overcenter. Features reverse action design. For tension adjustment and fitting tolerance latch has 10mm of screw adjustment.



İsteğe baęlı galvaniz kaplı ve paslanmaz çelikten yapılır.
Optional galvanized and stainless steel

Size	b	M	d	d1	s	h	l	m	n	c	k	g	e	o
2	80-95	5	4,3	4,3	2	15	56	20,5	25	18	6	6	21	14
4	100-125	6	6	5	2,5	17	70	25,5	30	17,5	9,5	13	23	17

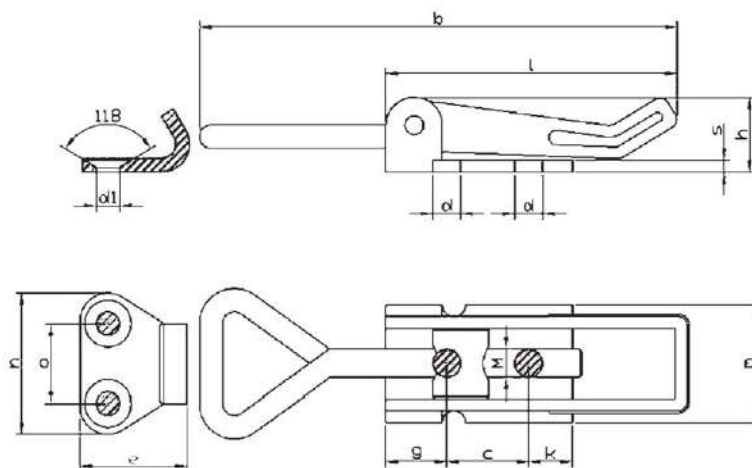

M52S/6 Spannerverschluss-einstellbar

M52S/6

Light duty toggle clamp

Light duty adjustable draw latch/toggle clamp/under centre fastener with variable overcenter. Features reverse action design. For tension adjustment and fitting tolerance latch has 10mm of screw adjustment.



Optional galvanized and stainless steel

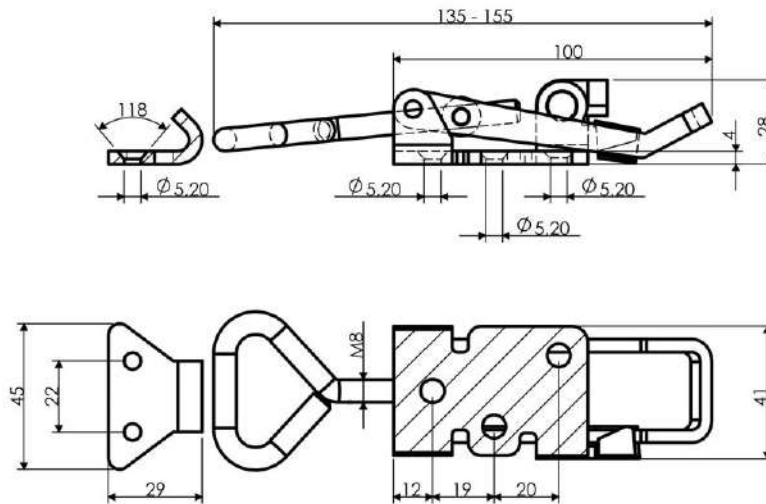

M60 Schubstangenspanner mit kleinem Winkelfuß

M60

Push-pull type toggle clamps

All parts are zinc plated; with red oil resistant plastic handle.
Bushes case-hardened and greased.
Stainless steel pivots.
Supplied complete with clamping screw and rubber nose.



Size	F1 (kN)	F2 (kN)				
0	0.8	0.8	40	110	M4 x 20	80
1	1.0	1.0	58	120	M4 x 20	120
2	2.0	2.0	80	175	M6 x 25	270
3	2.5	2.5	102	190	M8 x 35	450
5	4.5	4.5	123	230	M12 x 50	960

Size	a	b	c	d	f	g	h	k	l	m	n	o
0	6	34.5	16	4.5	16.5	16	12	M10 x 1	10	16	25	7
1	8	44	20	4.5	20	15	15.5	M12 x 1.5	13.5	20	30	7
2	10	59	28	5.5	28	28.5	22	M16 x 1.5	16	39.5	50	12.5
3	12	70	32	6.5	32	30	27	M20 x 1.5	19	42	60.5	15
5	16	82	40	8.5	36	28	30	M24 x 1.5	26	46	65	15

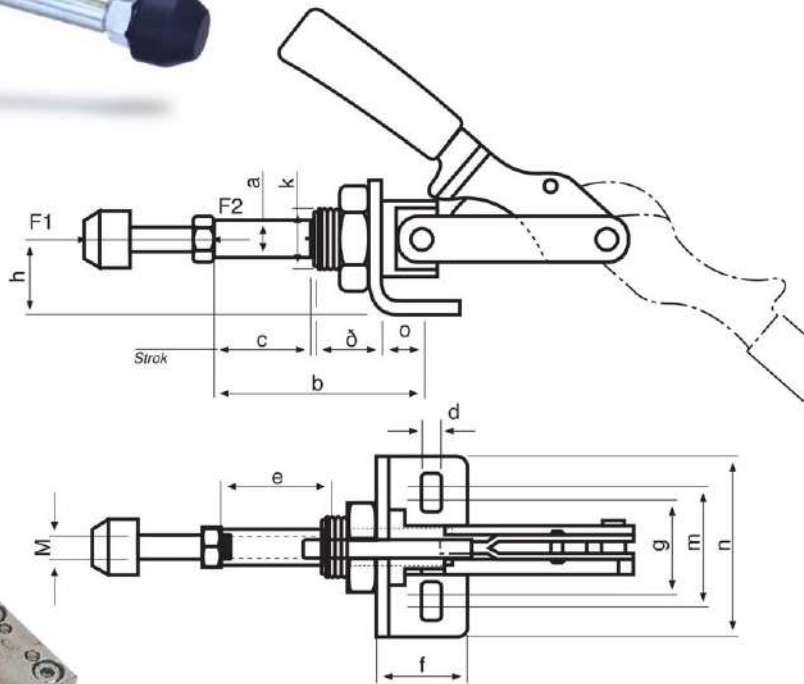





M61 Schubstangenspanner ohne Konsole

M61

Push-pull type toggle clamps

All parts are zinc plated; with red oil resistant plastic handle.
Bushes case-hardened and greased.
Stainless steel pivots.
Supplied complete with clamping screw and rubber nose.



Size	F1 (kN)	F2 (kN)				
2	1.0	1.0	85	70	M6 x 35	130
3	2.5	2.5	135	110	M8 x 35	320
5	4.0	4.0	155	175	M12 x 50	1200

Size	a	b	c	e	k	l	M
2	10	14-35	21	15	M16 x 1.5	13	M6
3	12	18-56	38	25	M20 x 1.5	16	M8
5	16	25-92	67	35	M24 x 1.5	22	M12

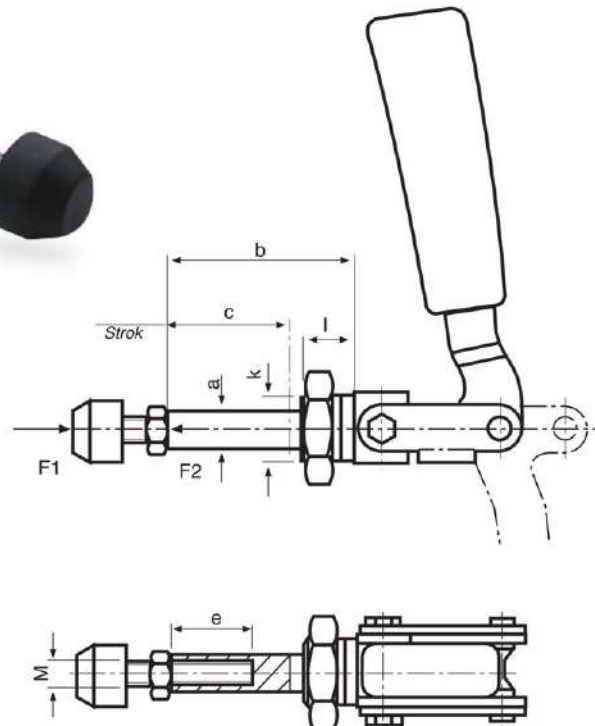

M62 Schubstangenspanner

M62

Push-pull type toggle clamps

*All parts are zinc plated; with red oil resistant plastic handle.
Bushes case-hardened and greased. Stainless steel pivots.*

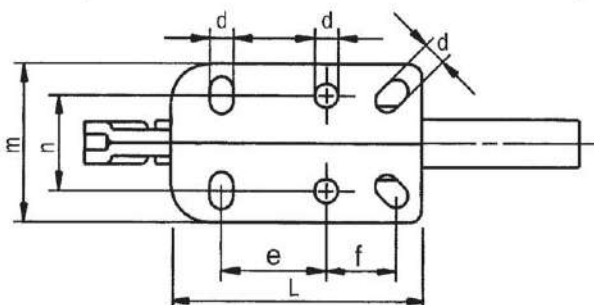
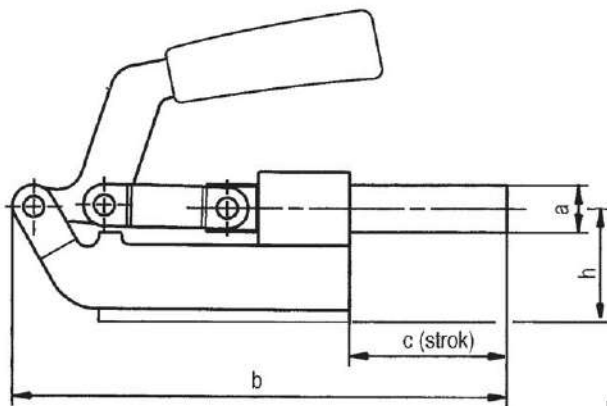
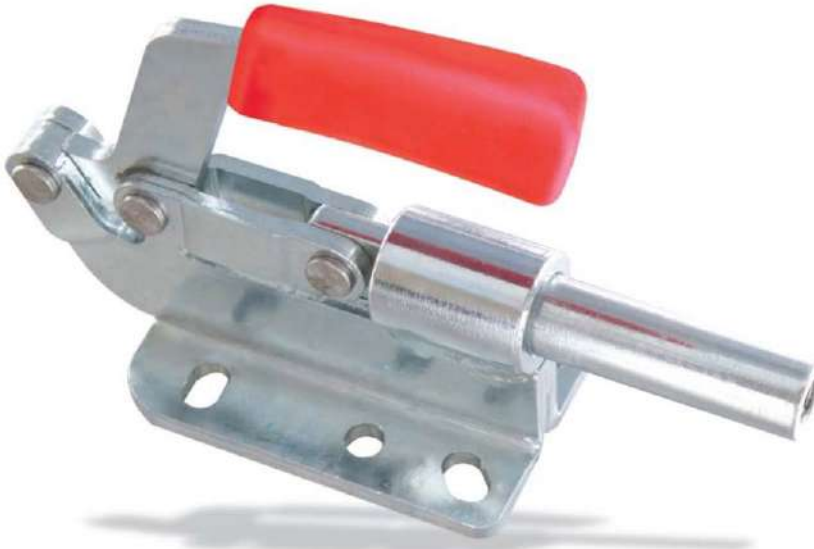

Size	F1 (kN)	F2 (kN)				
3	2.0	2.0	95	186	M8 x 45	500
5	4.0	4.0	115	190	M10 x 40	950

Size	a	b	c	d	e	f	h	l	m	n
3	14	134	32	6.5	30	37	32.5	100	55	32.5
5	18	190	44	9	40	26.8	44	96	60	36

M64 Schubstangenspanner – schwere Ausführung

M64

Push-pull type toggle clamps

All parts are zinc plated; with red oil resistant plastic handle.
Bushes case-hardened and greased. Stainless steel pivots. Supplied complete with clamping screw
and rubber nose.



Size	F1 (kN)	F2 (kN)				
3	4.0	4.0	115	191	M8 x 35	630
5	10.0	10.0	133	245	M12 x 50	1620
7	25.0	25.0	170	333	M12 x 50	3610

Size	a	b	c	d	e	f	g	h	k	l	m	n
3	12	72	32	6.5	30	99	36	32	28	40	43	63
5	16	86	40	8.5	45	128	43.5	42.5	35	75	53	72
7	22	98	50	11.5	45	163	65	55	40	100	73	96

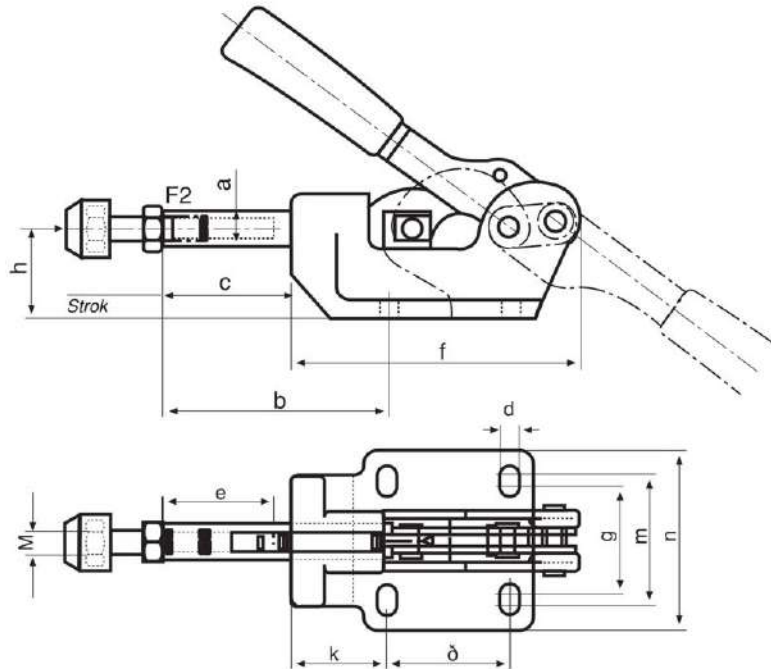

M64 Anwendungsbeispiel

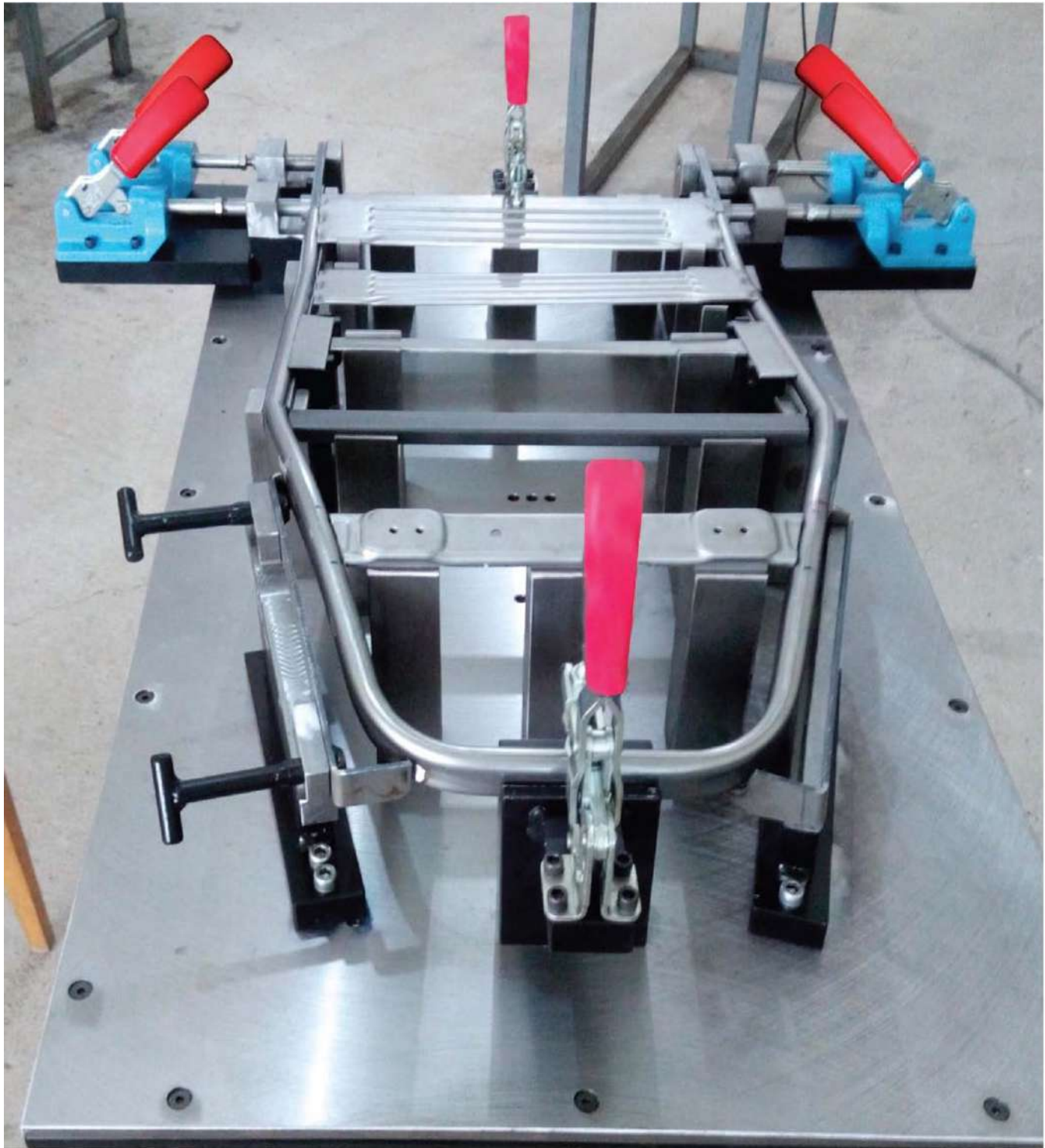

M66 Schubstangenspanner – schwere Ausführung

M66

Heavy Push-pull type toggle clamps

Heavy duty type with long rod-guide. Base of malleable casting, burnished. Lever-parts and rod of tempering steel, burnished. Hardend bolts, maintenancefree sintered bushes. Handle made of red oil-resistant plastic. Complete with tempered clamping screw.



Size	F1 (kN)	F2 (kN)				
4	7	7	65	122	M8 x 35	600
5	12	12	95	185	M10 x 50	1800

/Size	a	b	c	d	e	f	g	h	k	l	m	n
4	14	56	30.5	5.5	40	90	33.3	12	23	36.5	-	49
5	20	63	50	8.5	50	134	41.0	18	8	35	41	62

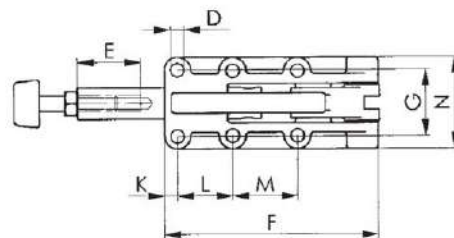
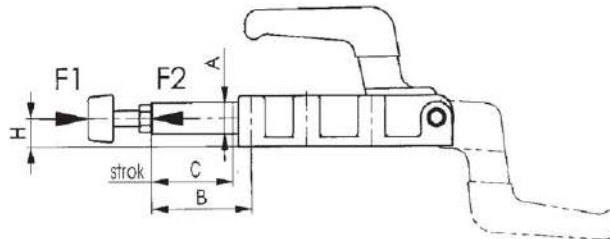

M66C Schubstangenspanner – schwere Ausführung

M66C

Heavy Push-pull type toggle clamps

Heavy duty type with long rod-guide.
Base of malleable casting, burnished. Lever-parts and rod of tempering steel, burnished.
Hardend bolts, maintenancefree sintered bushes.
Lever galvanized and passivated.
Handle made of red oil-resistant plastic. Complete with tempered clamping screw.

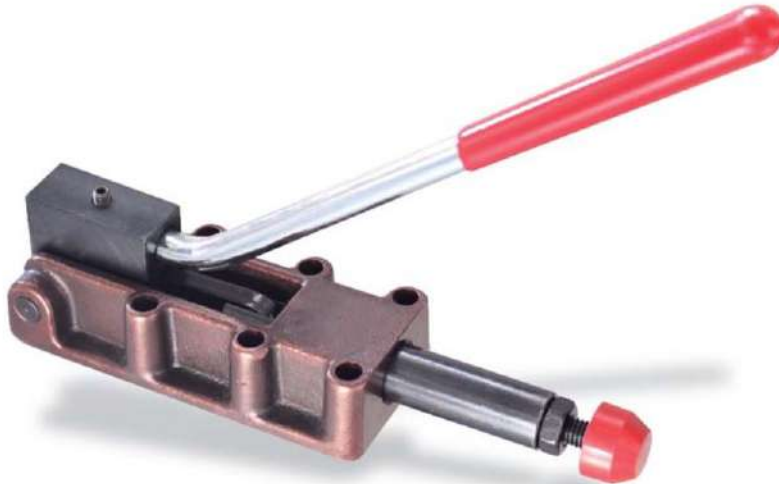

Size	F1 (kN)	F2 (kN)				
4	7	7	65	122	M8 x 35	600
5	12	12	95	185	M10 x 50	1800

Size	a	b	c	d	e	f	g	h	k	l	m	n
4	14	56	30.5	5.5	40	90	33.3	12	23	36.5	-	49
5	20	63	50	8.5	50	134	41.0	18	8	35.5	40.5	62

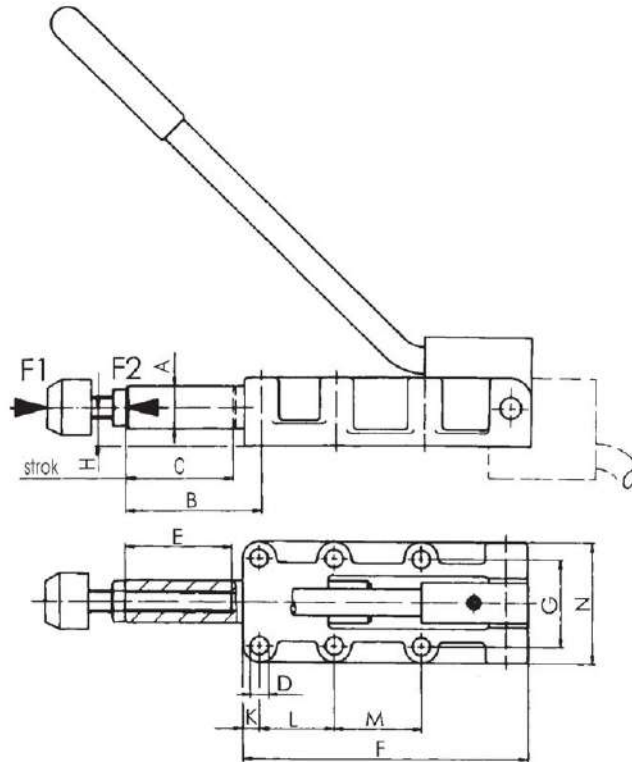

M68 Schubstangenspanner

M68

Push-pull type toggle clamps

All parts are zinc plated; with red oil resistant plastic handle.
Bushes case-hardened and greased.



Size	F1 (kN)	F2 (kN)				
4	15.0	15.0	166	190	M10 x 40	2000
5	15.0	15.0	172	269	M10 x 40	2500
6	15.0	15.0	172	380	M10 x 40	2800

Size	a	b	c	d	e	h	s	m	n	ød	ø2d	ød1	ød2	VD
4	145	154	40	25	45	30	10	70	90	20	35	8	14	M10 x 40
5	200	160	64	25	45	30	10	70	90	20	35	8	14	M10 x 40
6	210	160	90	25	45	30	10	70	90	20	35	8	14	M10 x 40

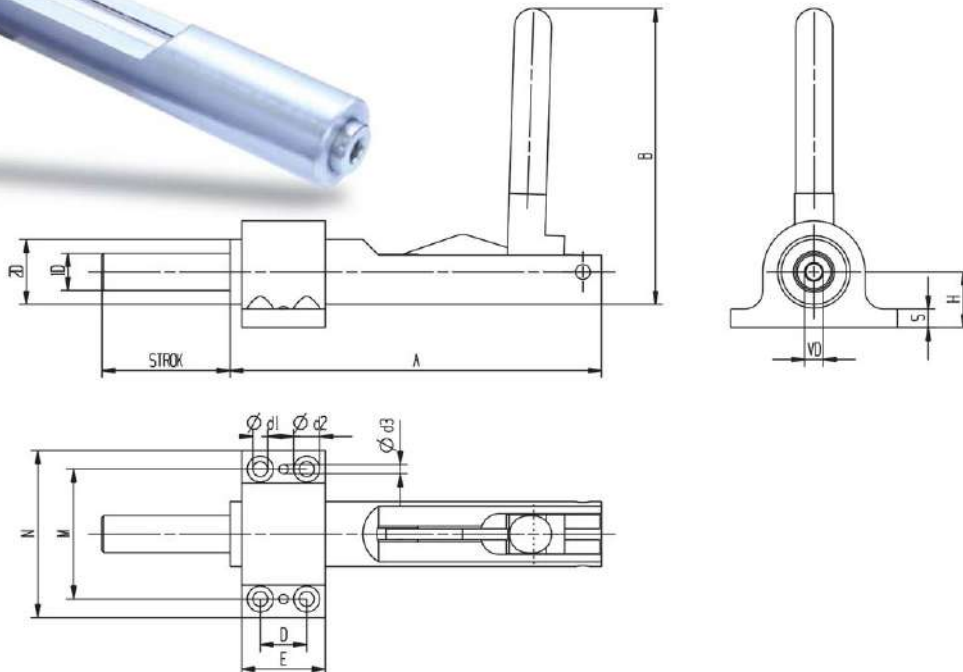

M70 Zugspanner-Niederspanner senkrecht



M70

Squeezing type toggle clamps

Steel body. Galvanized and passivated.

Ergonomic handle of red high quality oil-resistant plastic.

Supplied complete with tempered, galvanized clamping screw

Size	F3 (kN)		
4	4.00	M12 x 80	600

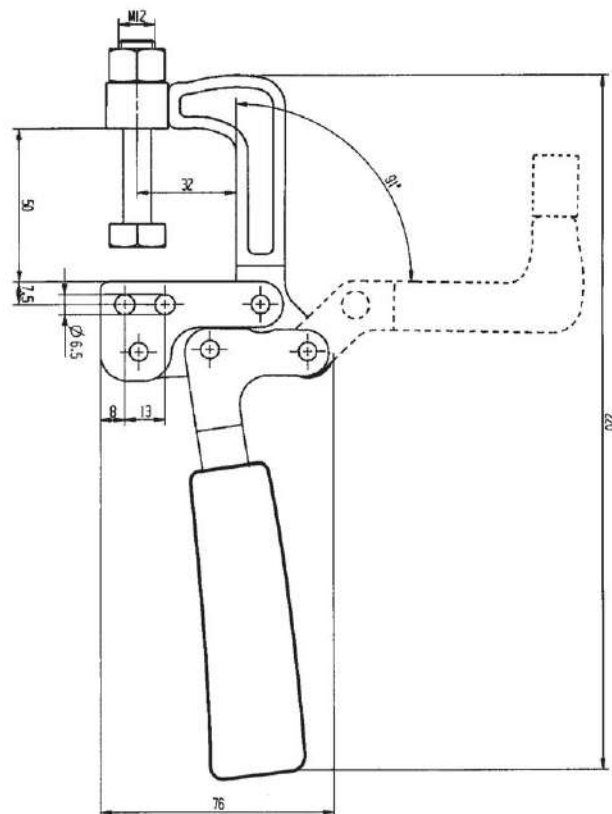

ANWENDUNGSBEISPIEL

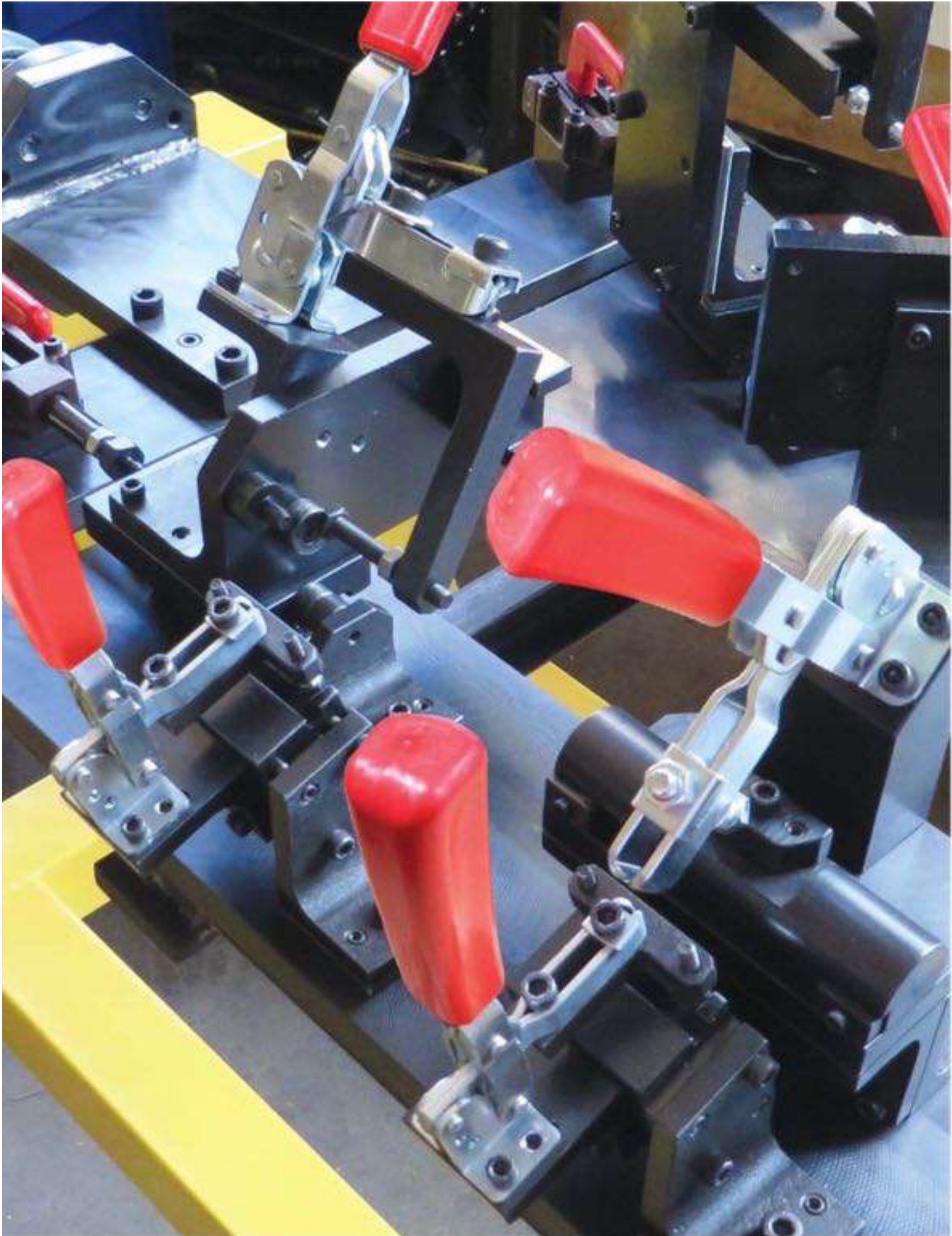

M10S Senkrechtspanner mit Sicherheitsverriegelung

M10S

Vertical toggle clamp with release lever

Zinc plated, with red oil resistant plastic handles, bushes case hardened and greased, supplied complete with clamping screw and rubber nose.



Size	F1 (kN)	F2 (kN)				
3	1.8	2.5	200	105	M8 x 45	400
4	2.0	3.0	230	140	M8 x 65	790



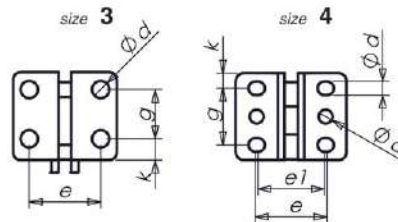
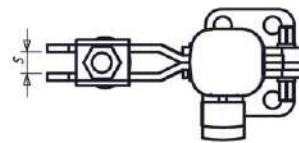
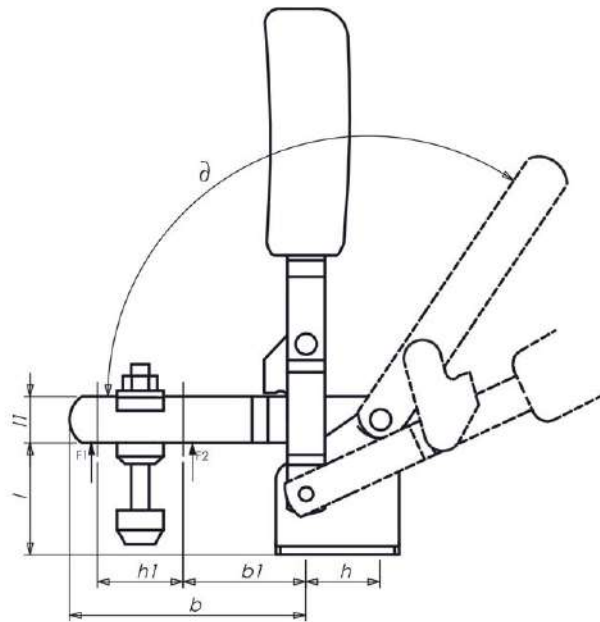

Size	b	b1	d	e	e1	g	h	h1	k	l	l1	s	∅
3	72	27	7	32	-	20	16	29	7.5	36	18	8.5	105°
4	101	30	8.5	45	34	34.5	22	61	9.25	48	20	9	105°



M11S Senkrechtspanner mit Sicherheitsverriegelung

M11S

Vertical toggle clamp with release lever
with open clamping arm and vertical base.
Galvanized and passivated.
Rivets of stainless steel running in case hardened bushing, with bearing spots greased.
Ergonomic handle of red high quality oil-resistant plastic.
Supplied complete with tempered, galvanized clamping screw no.802

Size	F1 (kN)	F2 (kN)			hw		
3	1.8	2.5	210	105	8 ÷ 20	M8 x 45	400
4	2.0	3.0	255	140	5 ÷ 33	M8 x 65	790

Size	a	b	c	d	e	f	g	h	i	k	l	m	n	o	q	∅
3	8.5	72	20	7	29	27	-	50	18	7.5	-	44	-	6	16	105°
4	9	101	34.5	8.5	61	30	56.5	71.5	20	9.25	17	60	59	8	22	105°

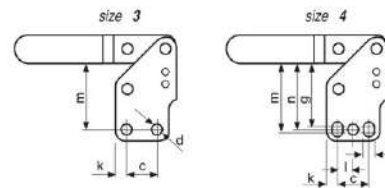
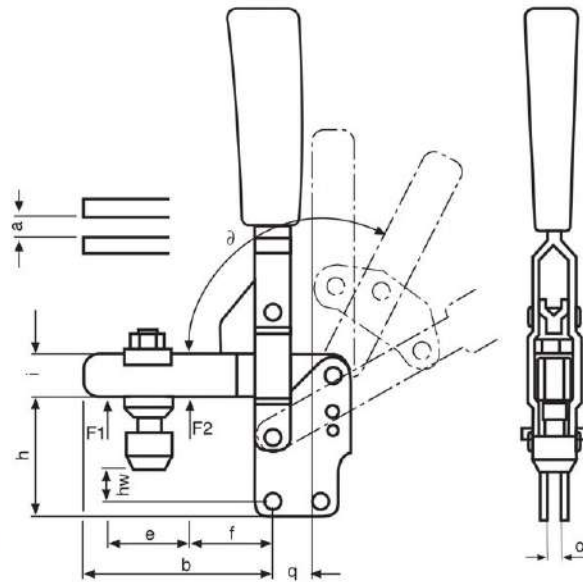

M12S Senkrechtspanner mit Sicherheitsverriegelung





M12S

Vertical toggle clamp with release lever
with open clamping arm and vertical base.

Galvanized and passivated. Rivets of stainless steel running in case hardened bushing, with bearing spots greased.

Ergonomic handle of red high quality oil-resistant plastic.

Supplied complete with tempered, galvanized clamping screw no.803

Size	F1 (kN)	F2 (kN)			hw		
3	1.8	2.5	235	105	6 ÷ 18	M8 x 45	470
4	2	3	270	141	11 ÷ 40	M8 x 65	790

Size	a	b	c	d	e	f	g	h	i	k	l	m	o	q	∅
3	8.2	58	31.5	7.5	30	14	24	73	18	7	45	39	6	31	105 [∅]
4	10	77.5	42	8.5	35	19	28	77	20	7	60	42	8	35	105 [∅]

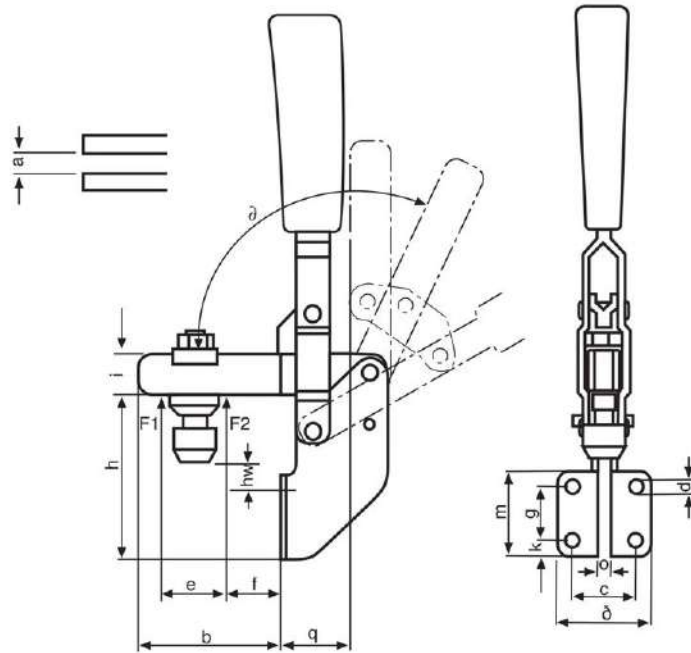
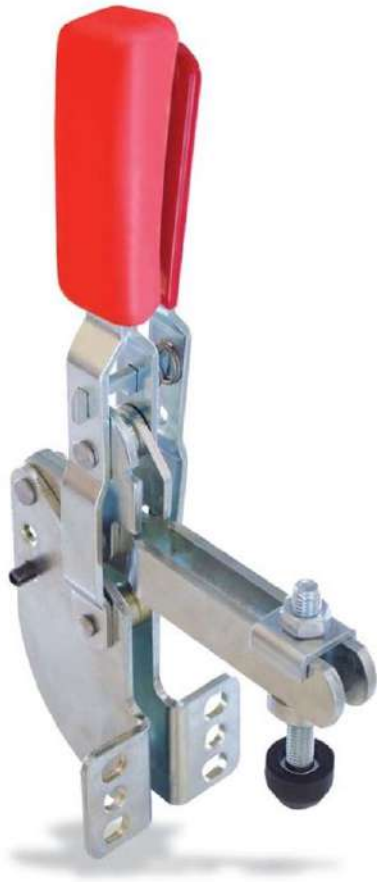

M20S Waagrechtspanner mit Sicherheitsverriegelung

M20S

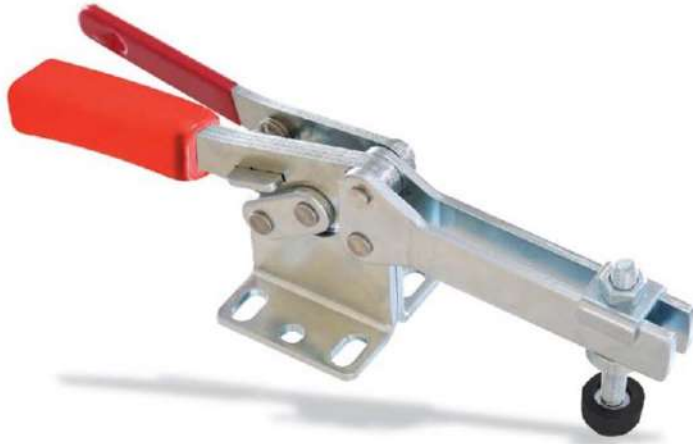

Size	F1 (kN)	F2 (kN)	Diagram		hw	Diagram	g
3	1.8	2.5	48	221	-1 ± 11	M8 x 45	340

Size	a	b	c	d	e	f	g	h	i	k	l	m	n	q
3	8	72	28	6.5	44	22	21.5	33	15	7	-	25.5	21	8

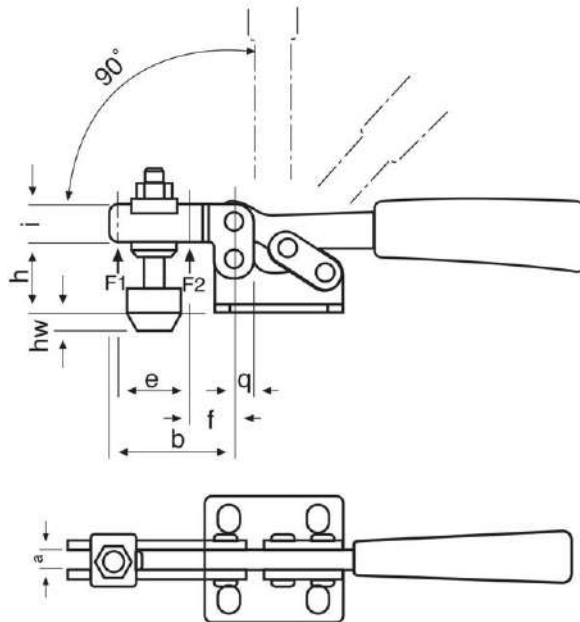
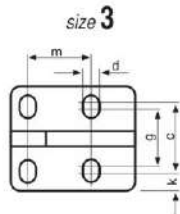

M21S Waagrechtspanner mit Sicherheitsverriegelung

M21S

Horizontal toggle clamp with release lever

Zinc plated, with red oil resistant plastic handles, bushes case hardened and greased, supplied complete with clamping screw and rubber nose.

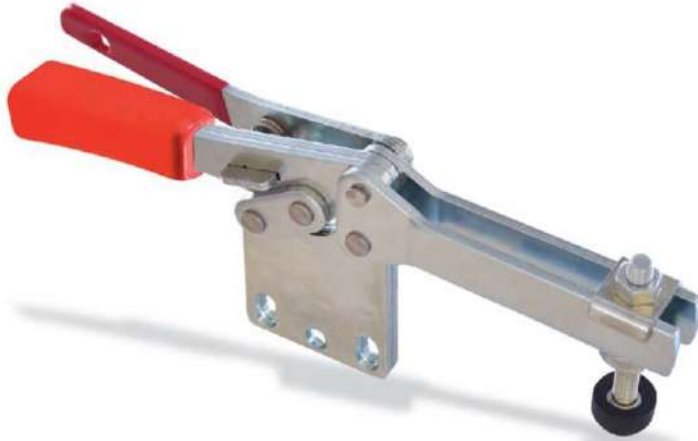

Size	F1 (kN)	F2 (kN)				
3	1.8	2.5	63	221	M8 x 45	340

Size	a	b	c	d	e	f	h	i	k	l	m	n	o	q
3	8	72	25.5	6.5	44	22	49	15	7	-	43	38	6	8

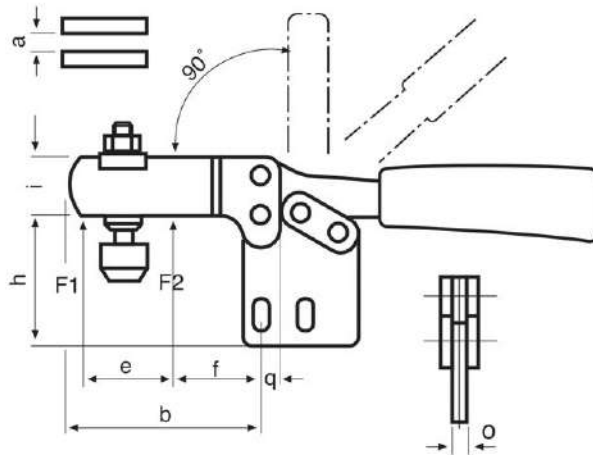

size 3

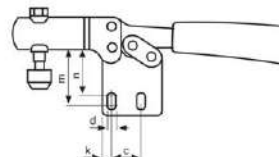

M22S Waagrechtspanner mit Sicherheitsverriegelung

M22S

Horizontal toggle clamp with release lever

Zinc plated, with red oil resistant plastic handles, bushes case hardened and greased, supplied complete with clamping screw and rubber nose.

Size	F1 (kN)	F2 (kN)					hw		
3	1.8	2.5	86	221	6+18	M8 x 45	400		

	a	b	c	d	e	f	g	h	i	k	m	n	o	p	q
3	8	58	24	6.5	42	8	28	72	15	7	38	12	21	23	41

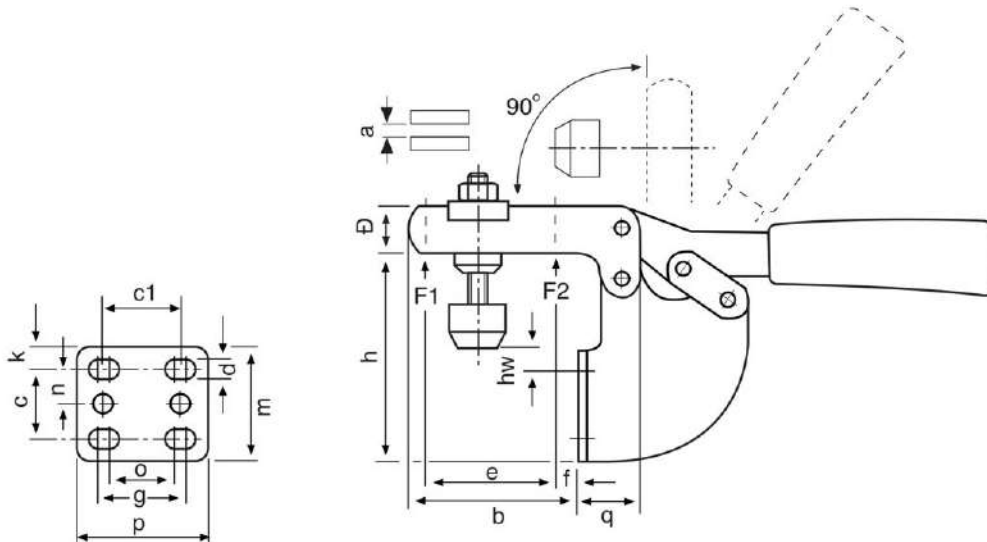
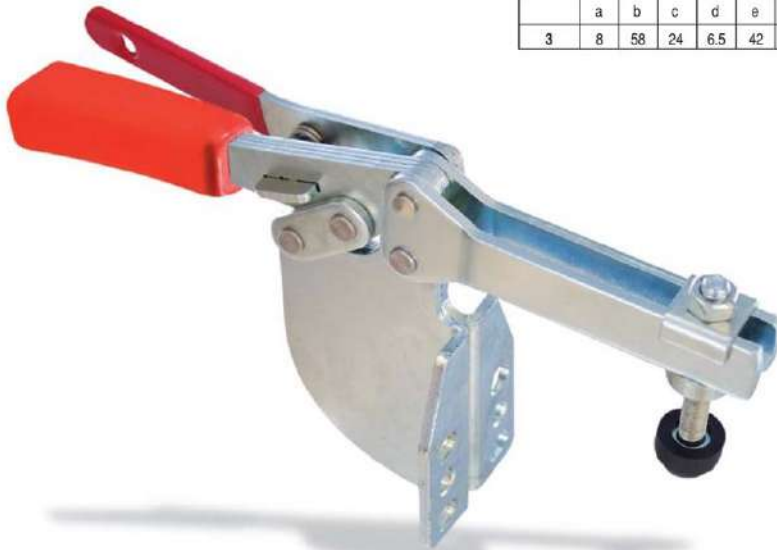

M40S Waagrechtspanner mit Sicherheitsverriegelung

M40S

Hook type toggle clamp with release lever

Galvanized and passivated.
Bushes case hardened and greased; rivets of stainless steel.
Hook and clamping sleeve tempered.
With traditional red oil-resistant plastic handle.

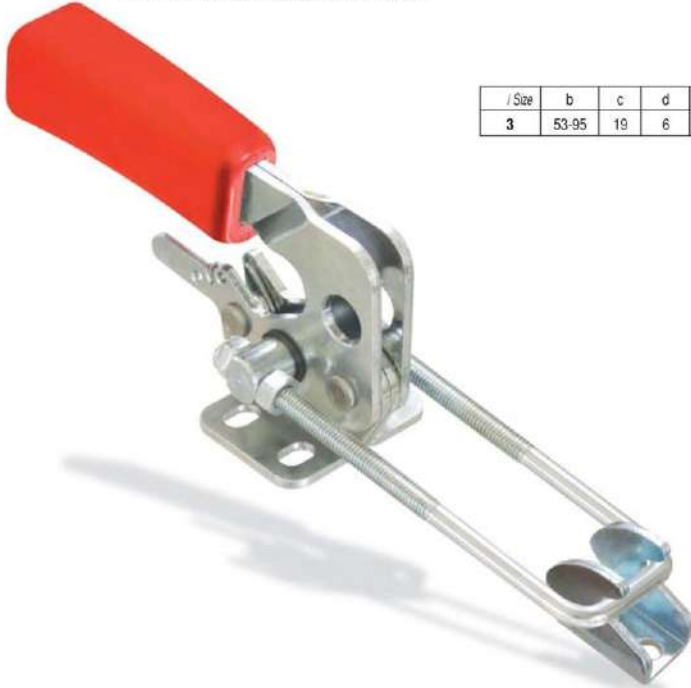

Size	↔ (kN)	Adjustm. distance (mm)			
3	2.5	42	64	102	300

/ Size	b	c	d	e	f	g	h	k	l	m	n	s	t
3	53-95	19	6	48-90	14	6.5	19	8	35	32	48	6	25

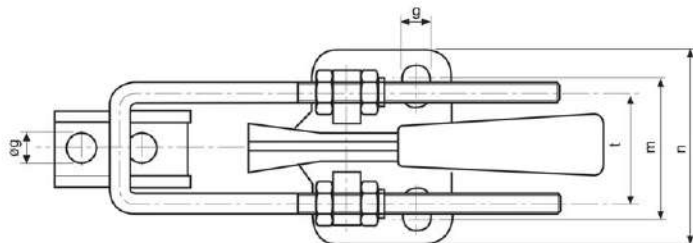
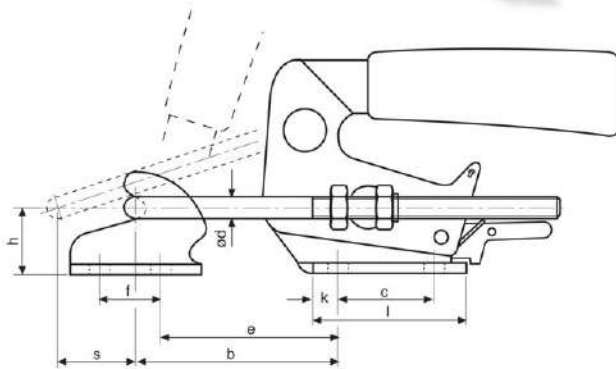





M46S Hakenspanner mit Sicherheitsverriegelung

M46S

Hook type toggle clamp with release lever
Galvanized and passivated.
Bushes case hardened and greased; rivets of stainless steel.
Hook and clamping sleeve tempered. With traditional red oil-resistant plastic handle.

/ Size	b	c	d	e	g	h	k	l	m	n	R	s
3	67-78	19	8	74.5 - 86.5	5.5	24	13	41	32-35	43	5.5	98

Size		Adjustin. distance (mm)			
3	3.0	12	36	230	300



Counter catch
Galvanized and passivated.
Bushes case hardened and greased; rivets of stainless steel.

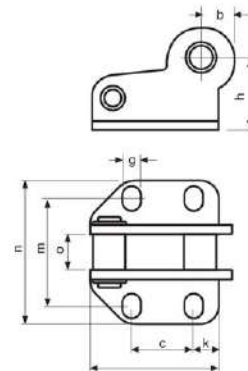
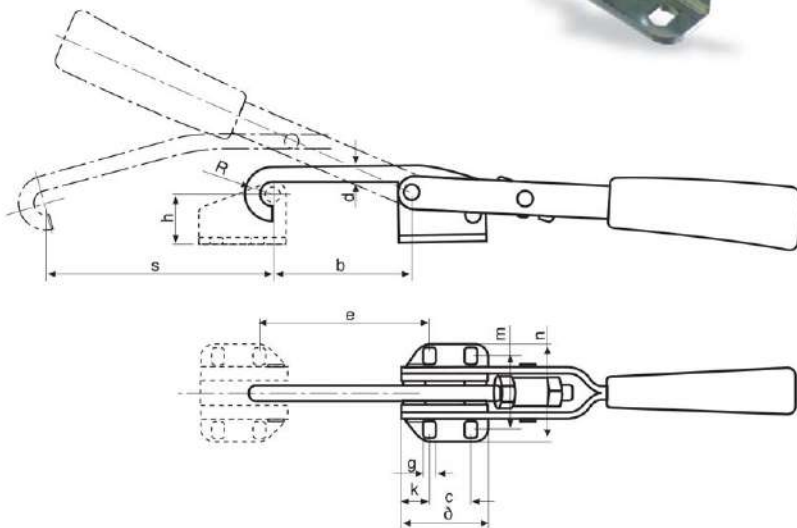





M10K Senkrechtspanner für optische Messtechnik

M10K

Vertical acting toggle clamps - black

Matte-black body with black oil resistant plastic handle.
Bushes case-hardened and greased.
Supplied complete with clamping screw and rubber nose.

Size	a	b	c	d	e	f	g	h	i	k	l	m	n	p	q	∅
0	5	34	13.5	4.5	16	10	8.5	17	8	4.5	-	25.5	-	-	10	88°
1	5.5	41	16	4.5	19	11	26.5	19.5	10	5.5	-	-	-	-	12	88°
2	6.2	51	20	5.3	24	10	23	26	12	6	11	30	26	3	13	100°
3	8.5	72	20	7	29	27	-	36	18	7.5	-	32	-	-	16	105°
4	9	101	34.5	8.5	61	30	34	48	20	9.25	17	45	-	-	22	105°
5	14	137	45	8.5	88	40	45	55	25	10.5	25	50	45	5	31.5	115°
6	14	165	50	10.5	90	55	-	70	30	13	-	55	-	-	35	115°

Size	F1 (kN)	F2 (kN)			hw		
0	0.5	0.7	90	50	-3 + 4	M4 x 25	50
1	0.8	1.1	105	60	-4 + 3	M5 x 30	114
2	1.0	1.2	140	76	-3 + 6	M6 x 35	178
3	1.8	2.5	200	105	0 + 12	M8 x 45	400
4	2.0	3.0	230	140	-8 + 21	M8 x 65	740
5	3.0	5.0	265	190	10 + 34	M12 x 80	1500
6	3.5	5.5	300	230	2 + 57	M12 x 110	2160

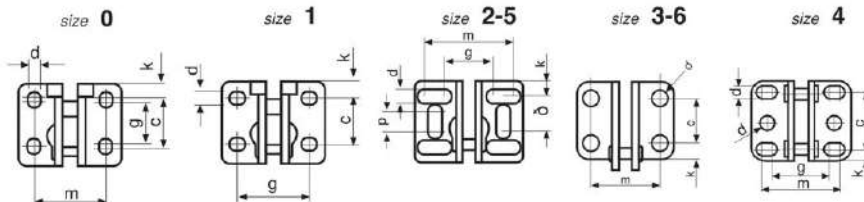
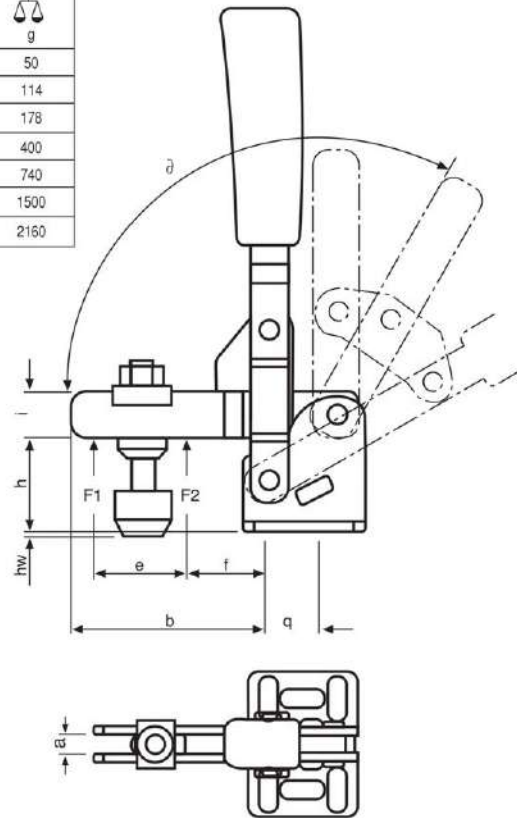

M20K Waagrechtspanner für optische Messtechnik

M20K

Horizontal acting toggle clamps - black
Matte-black body with black oil resistant plastic handle.
Bushes case-hardened and greased.
Supplied complete with clamping screw and rubber nose.



Size	F1 (kN)	F2 (kN)			hw		
0	0.25	0.40	23	85	-5 + 2	M4 x 25	37
1	0.80	1.10	30	128	-4 + 3	M5 x 30	112
2	1.00	1.20	44	158	-3 + 6	M6 x 35	182
3	1.80	2.50	48	221	-1 + 11	M8 x 45	340

Size	a	b	c	d	e	f	g	h	i	k	l	m	n	q
0	4	25	16	4,1	11	10	11	15	7	4	-	16	-	2
1	5	40	24	5,2	26	11	19,5	20	10	5,5	-	23	20,5	5
2	6	51	26	5,4	28	12	-	30	13,5	6	13	30	22	6
3	8	72	28	6,5	44	22	21,5	33	15	7	-	25,5	21	8

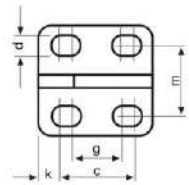

size 0

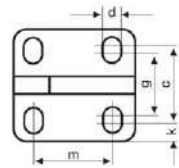

size 1

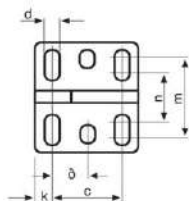

size 2

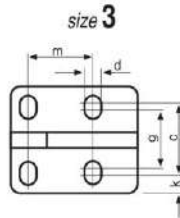

size 3

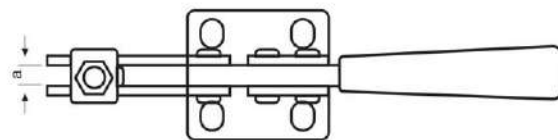
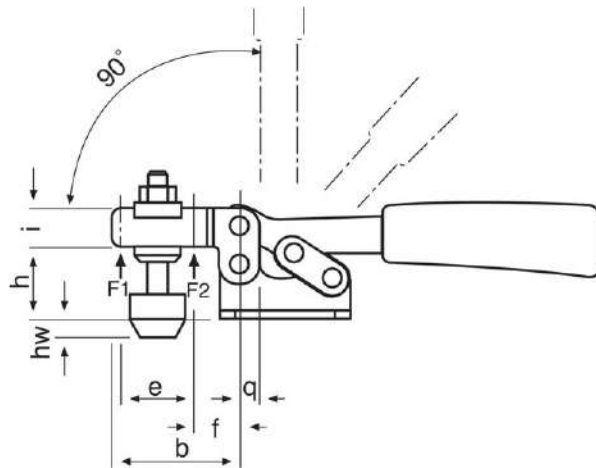

EDELSTAHL

Stainless Steels Products



M10P Senkrechtspanner – rostfreie Version

M10P

Vertical acting toggle clamps

Zinc plated, with red oil resistant plastic handles, bushes case hardened and greased, supplied complete with clamping screw and rubber nose.



Size	a	b	c	d	e	f	g	h	i	k	l	m	n	p	q	∅
1	5.5	41	16	4.5	19	11	26.5	19.5	10	5.5	-	-	-	-	12	88°
2	6.2	51	20	5.3	24	10	23	26	12	6	11	30	26	3	13	100°
3	8.5	72	20	7	29	27	-	36	18	7.5	-	32	-	-	16	105°
4	9	101	34.5	8.5	61	30	34	48	20	9.25	17	45	-	-	22	105°

Size	F1 (kN)	F2 (kN)			hw		
1	0.8	1.1	105	60	-4 ÷ 3	M5 x 30	114
2	1.0	1.2	140	76	-3 ÷ 6	M6 x 35	178
3	1.8	2.5	200	105	0 ÷ 12	M8 x 45	400
4	2.0	3.0	230	140	-8 ÷ 21	M8 x 65	740

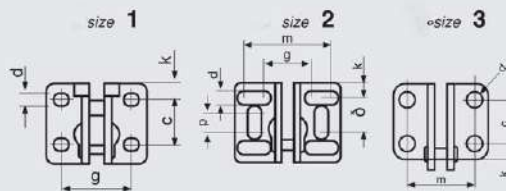
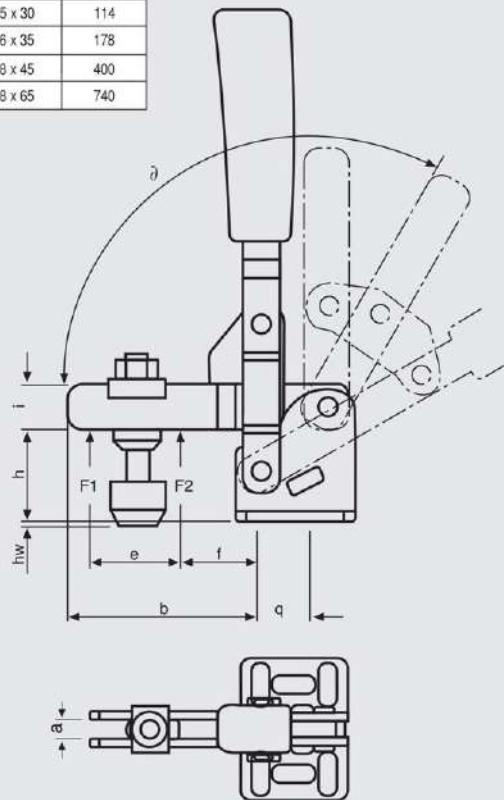

M20P Waagrechtspanner – rostfreie Version

M20P

Horizontal acting toggle clamps

Zinc plated; with red oil resistant plastic handle.

Bushes case-hardened and greased.

Supplied complete with clamping screw and rubber nose.



Size	F1 (kN)	F2 (kN)					g
0	0.25	0.40	23	85	M4 x 25		37
1	0.80	1.10	30	128	M5 x 30		112
2	1.00	1.20	44	158	M6 x 35		182
3	1.80	2.50	48	221	M8 x 45		340

Size	b	b1	c	c1	d	e	g	h	h1	l	l1	s	q
0	25	2	16	-	4.1	4	11	16	11	15	7	4	10
1	40	5	24	19.5	5.2	5.5	26	23	-	20	10	5	11
2	51	6	26	22	5.4	6	28	26	13	30	13.5	6	12
3	72	8	28	21	6.5	7	44	25.5	-	33	15	8	22

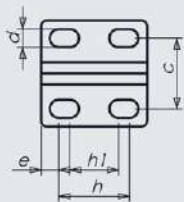

size 0

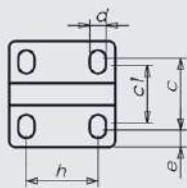

size 1-3

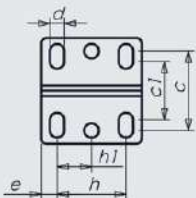

size 2

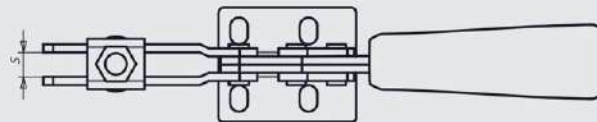
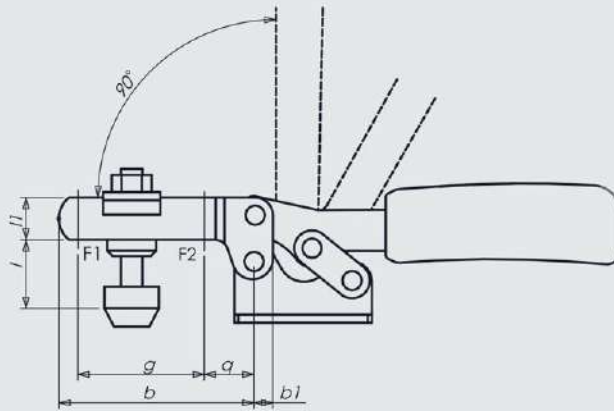

M40P Verschlussspanner – rostfreie Version

M40P

Hook type toggle clamps

Galvanized and passivated.

Bushes case hardened and greased; rivets of stainless steel.

Hook and clamping sleeve tempered.

With traditional red oil-resistant plastic handle.

Size	↔ (kN)	Ayar Aralık Adjustn. distance (mm)			
1	1	26	28	60	90
2	1.4	32	43	70	110
3	2.5	42	64	102	300
4	4.5	55	84	140	710

Size	b	c	d	e	f	g	h	k	l	m	n	s	t
1	30-65	16	3.5	18-28	10	4.5	12	5.5	26.5	21	28	4	18.5
2	42-74	13	4	38-70	11	5.2	12	6.5	26	24	38	6	19
3	53-95	19	6	48-90	14	6.5	19	8	35	32	48	6	25
4	72-127	32	8	65-120	19	8.5	25	9.5	51	45	65	13	36

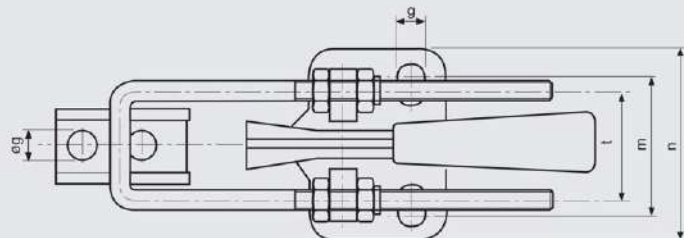
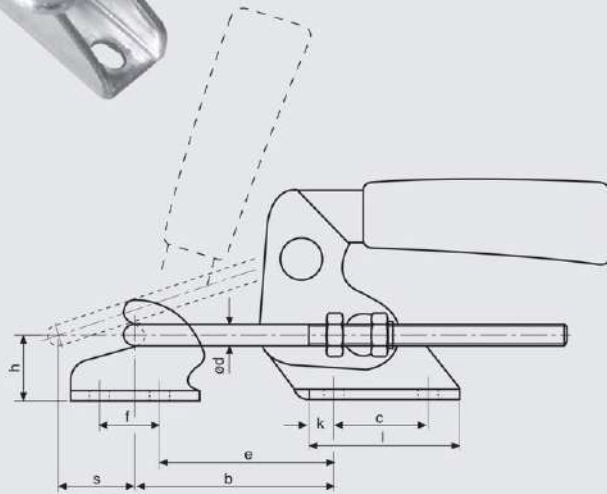

Pneumatische Automations-Kraftspanner



P10 Automations-Kraftspanner

P10

Pneumatic toggle clamp - Double acting

Mini design in block version for clamping and grasping uses.

High-strength aluminium, red anodised. Magnetic piston for end-position monitoring. Clamping arm made of steel, burnished, with three holes.

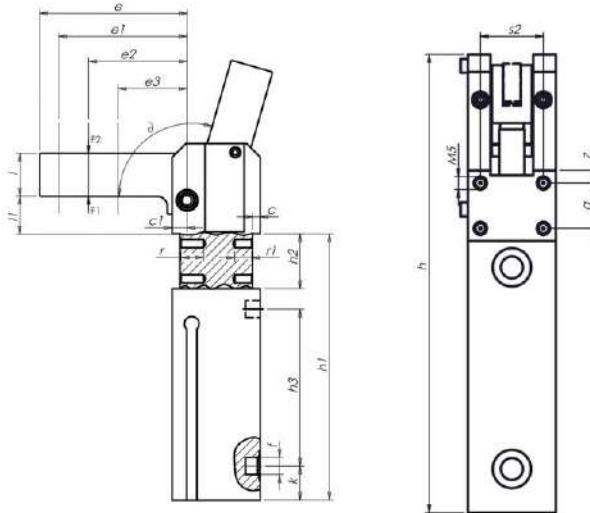

Red or Blue colour options

Size	Clamping Moment (Nm)	Holding Moment (Nm)	g
20	15	54	550
25	25	74	850

Size	c	c1	d	d1	e1	e2	e3	f	g	g2	h	h1	h2	h3	k	l	l1	r	r1	s	s1	s2	T	T1	z	φ	Piston
20	3	7	5	6.5	52	42	32	G1/8	15	8	158	120	25	69	15	18	15	8	6	30	12	20	39	22	5	105°	20
25	4	7.5	6	8.5	65	52.5	40	G1/8	18	10	182	136	28	80	17.5	22	19	8	6	35	16	25	45	25	5	105°	25

Max. Betriebsdruck 6 bar!
Max. pressure 6 bar!

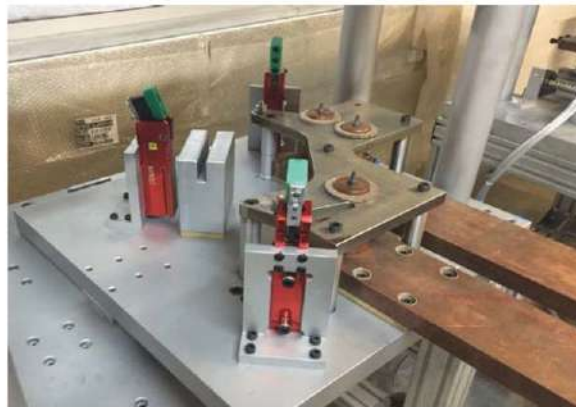

P12 Pneumatischer Hebelspanner

P12

Pneumatic link toggle clamp - Double acting
 Parts of mechanism are made of steel and blued.
 Piston rod non-rusting, polished.
 Body is made of aluminium, anodised.HART-COAT® surface for wear-resistance.
 Complete with clamping screw

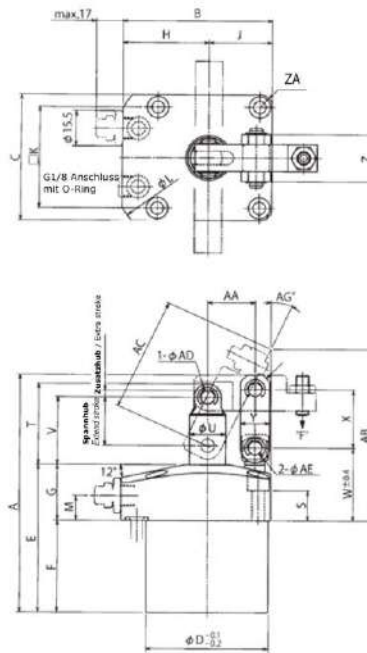

ANSCHLUSSMASSE
Dimensions of mounting area

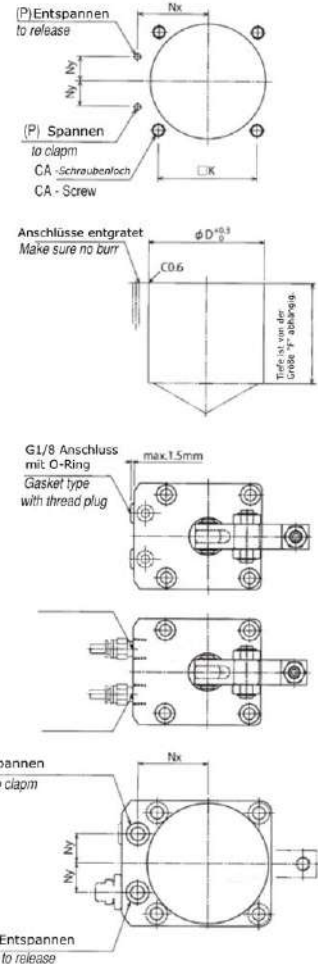

Größe / Size	Gesamthub / Full stroke	Spannhub / Extend stroke	Zusatzhub / Extra stroke	Max. (F) (kN)	Min. Betriebsdruck / Max. operating pressure	Max. Betriebsdruck / Min. operating pressure	Max. Belastungsdruck / Max. withstanding pressure	Betriebstemperatur / Operating temperature	Medium / Usable fluid	
32	23	20	3	0.42	10 bar	1 bar	15 bar	0 - 70°C	Druckluft - Dry air	400

Größe / Size	A	B	C	D	E	F	G	H	J	K	L	M	Nx	Ny	P	Q	R	S	T	U	V	W	X	Y	Z	AA	AB	AC	AD	AE	AG	CA	ZA
32	99	60	50	46	64	39	25	35	25	39	79	11	28	10	5	9.5	5.5	14	31.5	14	27	31	23.5	11	19	19.5	72	46.9	5	5	26.5	M5x0.8	R5

P20 Pneumatischer Schwenkspanner, Blockversion

P20

Pneumatic swing toggle clamp - Block version - Double acting

For recessed installation in fixtures.

Both compressed-air connections are in the flange.

Piston rod non-rusting, polished.

Body is made of aluminium, anodised.HART-COAT® surface for wear-resistance.

Including screw and spring washer for simple setting of the clamp arm position.

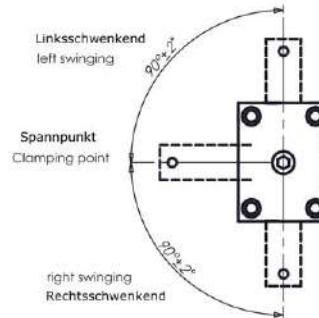
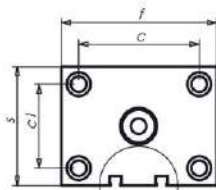
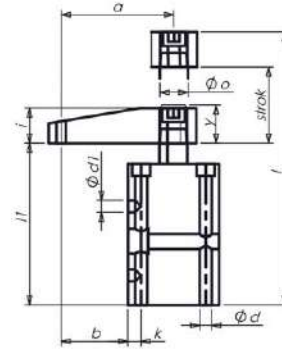
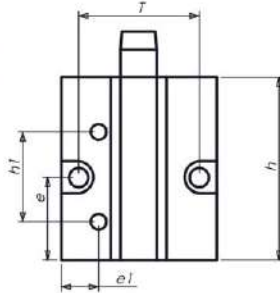

Größe Size	rechtsschwenkend Right swinging	linksschwenkend Left swinging	F3 (kN)	Anschlussgewinde für Andruckschraube Clamping Screw	g
32	✓	-	0.27	M8	800
32	-	✓	0.27	M8	800
40	✓	-	0.45	M8	920
40	-	✓	0.40	M8	920
50	✓	-	0.70	M12	1000
50	-	✓	0.70	M12	1000
63	✓	-	1.10	M12	1150
63	-	✓	1.10	M12	1150

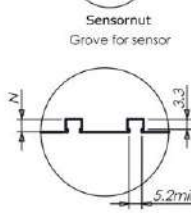

DESETEC SPANNTECHNIK
SPANNTWERKZEUGE UND NORMALIEN

Größe/Size	a	b	c	c1	Ød	Ød1	e	e1	f	h	h1	i	k	l	l1	n	ØQ	s	T	Piston Ø	Spannen Clamp*-Y	Strok
32	60	40	45	30	M8	8.5	43	12	80	90	50	20	7.5	145	96	6.5	16	45	45	32	15	30
40	70	45.5	52	37	M10	8.5	40	22	70	90	52	19	9	145	96	8	16	55	52	40	15	30
50	80	49	66	46	M10	10.5	45	66	85	100	53.5	25	9.5	162	106	6.5	16	65	66	50	15	30
63	90	52.5	80	60	M12	10.5	36	30	100	100	53	25	10	162	106	8.5	20	80	80	63	15	31

* Der Spanner darf nur innerhalb des Spannhubs Y belastet werden / Swing clamps may only be loaded during the clamping stroke "Y"

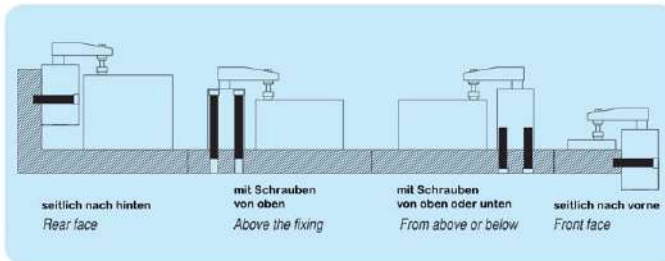

fitting and removing clamping arm



Fitting clamping arm
Hold clamping arm with spanner. Tighten/loosen screw.
Removing clamping arm
Loosen clamping arm from piston rod.
Caution: Do not strike sides of clamping arm.

P21 Pneumatischer Schwenkspanner

P21

Pneumatic swing toggle clamp - Double acting

For recessed installation in fixtures.

Both compressed-air connections are in the flange.

Piston rod non-rusting, polished.

Body is made of aluminium, anodised.HART-COAT® surface for wear-resistance.

Including screw and spring washer for simple setting of the clamp arm position.

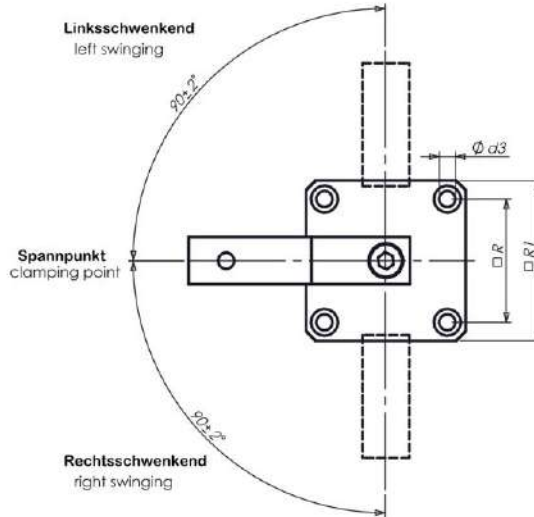

Größe Size	Rechtsschwenkend Right swinging	Linksschwenkend Left swinging	F3 (kN)	Anschlussgewinde für Anschlussschraube Clamping Screw	g
40	✓	-	0.45	M8	800
40	-	✓	0.45	M8	800

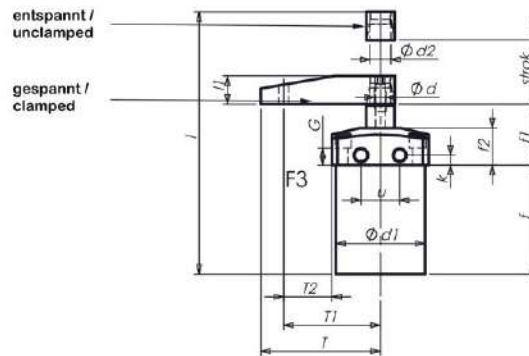

Größe/Size	d	d1	d2	d3	f	f1	l2	g	k	l	l1	R	R1	u	Piston Ø	Spanner-clamp* - Y	Strok
40	M8	M55x1.5	16	6.5	73	30	25	13	10.5	152	19	50	65	26	40	15	30

* Der Spanner darf nur innerhalb des Spannhubes Y belastet werden / Swing clamps may only be loaded during the clamping stroke "Y"

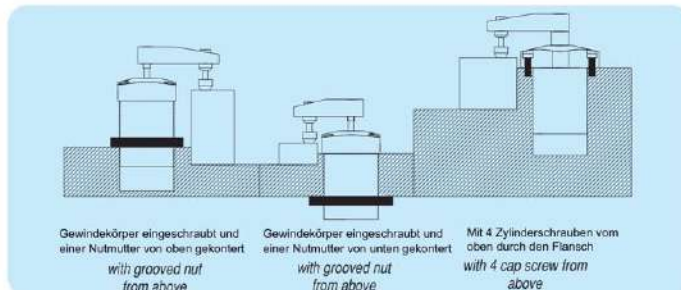

Fitting and removing clamping arm



Fitting clamping arm

Fold clamping arm with spanner. Tighten/loosen screw

Removing clamping arm

Loosen clamping arm from piston rod.

Caution: Do not strike sides of clamping arm.

P30 Automations-Kraftspanner

P30

*Pneumatic power toggle clamps
Double acting / High Torque
Modular design
Compact design
High holding torque
Long life cycle
Low weight (aluminium body)
Wide range of clamping arm variants
Adjustable opening angle without need for accessory parts 15°...135°
Mounting areas at front, back and sides
Toggle action mechanism
Manual unlocking in case of pressure drop
Inductive sensing module with LED display*

Size	Clamping Moment (Nm)	Holding Moment (Nm)	g
40	120	380	1400

Max. Betriebsdruck 6 bar !
Max pressure 6 bar !

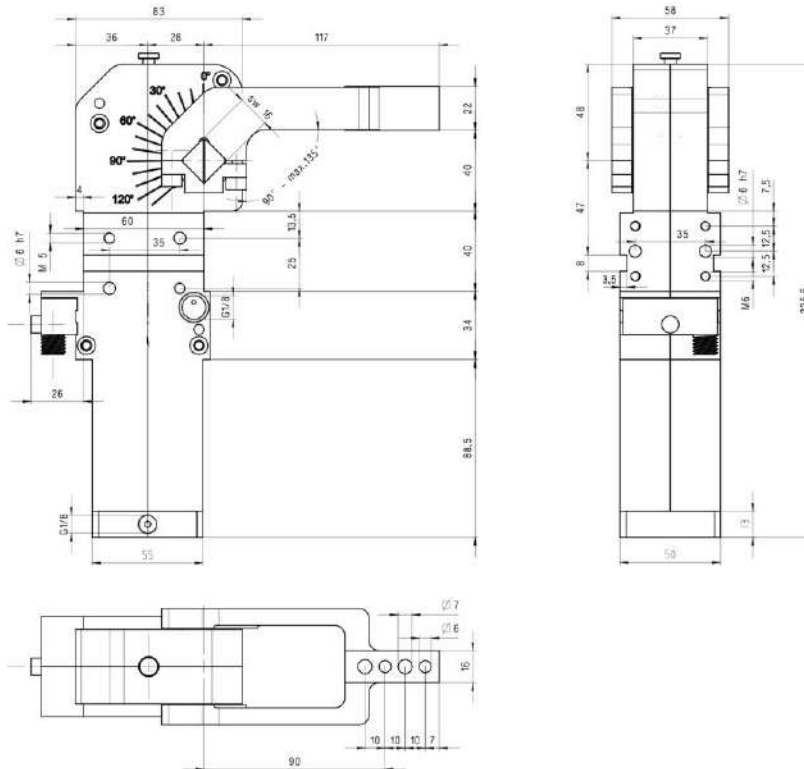
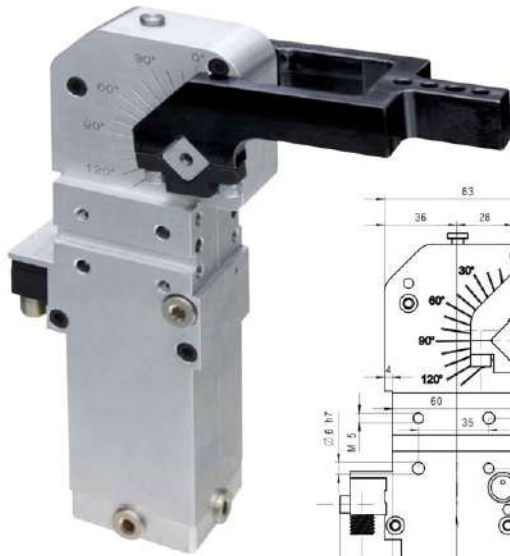

Applications

Automotive manufacturing, sheet processing industry, jig and general mechanical engineering.
Clamping, holding, gripping and positioning of metal sheets and other parts, mainly jigs and handling systems. Your best choice for carefully inserting and clamping components are the clamps with a handle lever.

P32 Automations-Kraftspanner

P32

*Pneumatic power toggle clamps
Double acting / High Torque
Modular design
Compact design
High holding torque
Long life cycle
Low weight (aluminium body)
Wide range of clamping arm variants
Adjustable opening angle without need for accessory parts 15°...135°
Mounting areas at front, back and sides
Toggle action mechanism
Manual unlocking in case of pressure drop
Inductive sensing module with LED display*



Size	Clamping Moment (Nm)	Holding Moment (Nm)	g
50	160	800	3500
63	380	1500	4600

Max. Betriebsdruck 6 bar !
Max. pressure 6 bar !

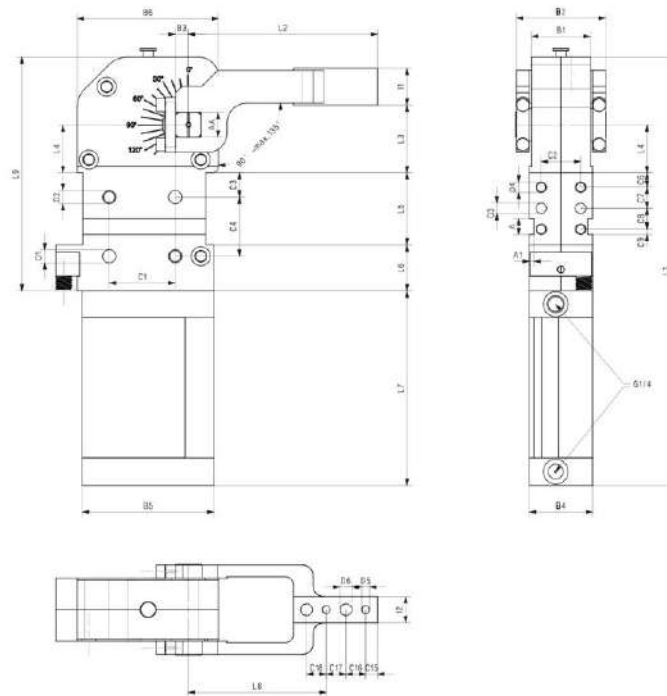

Applications

Automotive manufacturing, sheet processing industry, jig and general mechanical engineering.
Clamping, holding, gripping and positioning of metal sheets and other parts, mainly jigs and handling systems. Your best choice for carefully inserting and clamping components are the clamps with a handle lever.

Size	AA	A	A1	B1	B2	B3	B4	B5	B6	C1	C2	C3	C4	C6	C7	C8	C9	C15	C16	C17	C18	C19
50	19	12	3.5	45	68	10	48	100	107.5	50	30	18.5	45	11	16	16	4	9	15	15	15	15
63	22	12	3.5	52	78	10	54	140	107.5	50	30	18.5	45	11	16	16	4	9	15	15	15	15

Size	D1	D2	D3	D4	D5	D6	I1	I2	L1	L2	L3	L4	L5	L6	L7	L8	L9
50	10	M10	8	M8	6	9	28	20	326	144	51.5	36.5	55	35	148	105	178
63	10	M10	8	M8	6	9	28	20	340	144	51.5	36.5	55	35	148	105	178

P50 Pneumatischer Kniehebelspanner – vertikaler Zylinderanbau

P50

Pneumatic toggle clamp with vertical cylinder.

Space-saving angled form. Can be mounted vertically or horizontally. Fitted with pneumatic cylinder, double-acting, replaceable.

Magnetic piston for end-position monitoring.

Adjustable speed.

Clamp are galvanized and passivated. Stainless steel rivets running in case-hardened bushes.

Bearings are pre-lubricated.

Complete with tempered, galvanized clamping screw MS10/20 ve MS10Z

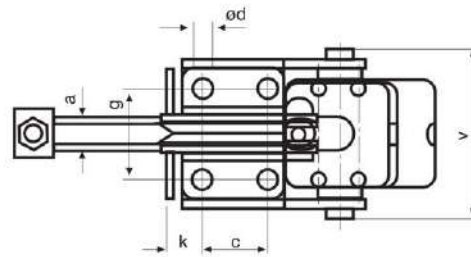
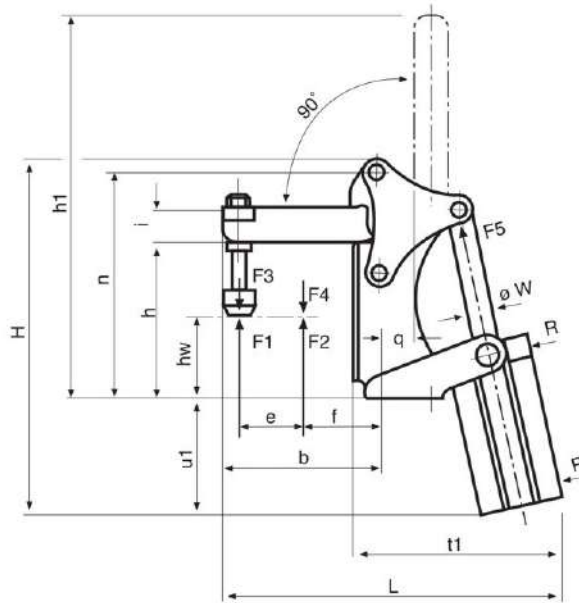

Größe Size	F1 (kN)	F2 (kN)	F3* (kN)	F4 (kN)	F5 (kN)	Vn**				
2	1.0	1.2	0.7	1.0	0.30	0.28	170	130	M6 x 35	800
3	1.4	2.5	0.6	1.1	0.50	0.35	205	160	M8 x 45	1100
4	2.0	3.0	1.5	2.2	0.75	0.08	260	220	M8 x 65	1600

*F3 + F4 = Max. Haltekraft bei 6 / Max. Holding capacity at 6 bar
**Vn = Luftverbrauch pro Doppelschub bei 6 bar (dm³) / Air consumption per double stroke at 6 bar (dm³)

Größe Size	a	b	c	ød	e	f	g	h	h1	h3	h4	h5	hw	i	k	n	q	t1	u1	v	øw	Strok	Zylinder Durchmesser	R
2	6	56	12.5	5.5	27	24	27.0	65	145	16	12.5	12.5	37 - 46	12	16	94	8	90	70	62	10	42	25	M5
3	8	82	16.0	6.5	41.2	30	25.4	72	185	18	16.0	-	38 - 50	18	16	108	13	105	90	70	12	52	32	G 1/8
4	10	101	32.0	8.5	61	30	45.0	100	240	22	32.0	32.0	50 - 79	20	17.5	145	22	135	105	85	16	62	40	G 1/8

Kolbendurchmesser x = F5 : Notwendiges Zylinderdurchmesser für die angegebene Kraft bei 6 bar

Pneumatische Kniehebelspanner



P52 Pneumatischer Kniehebelspanner-horizontaler Zylinder

P52

Pneumatic toggle clamps

With horizontal cylinder attachment

Fitted with pneumatic cylinder, double-acting anodised, installed and ready to connect. Magnetic piston for end-position monitoring.

With flow-restriction drillings for reduced speed. Clamps are galvanized and passivated. Stainless steel rivets running in case-hardened bushes. Bearings are pre-lubricated.

Complete with tempered, galvanized clamping screw MS10/20 ve MS10Z

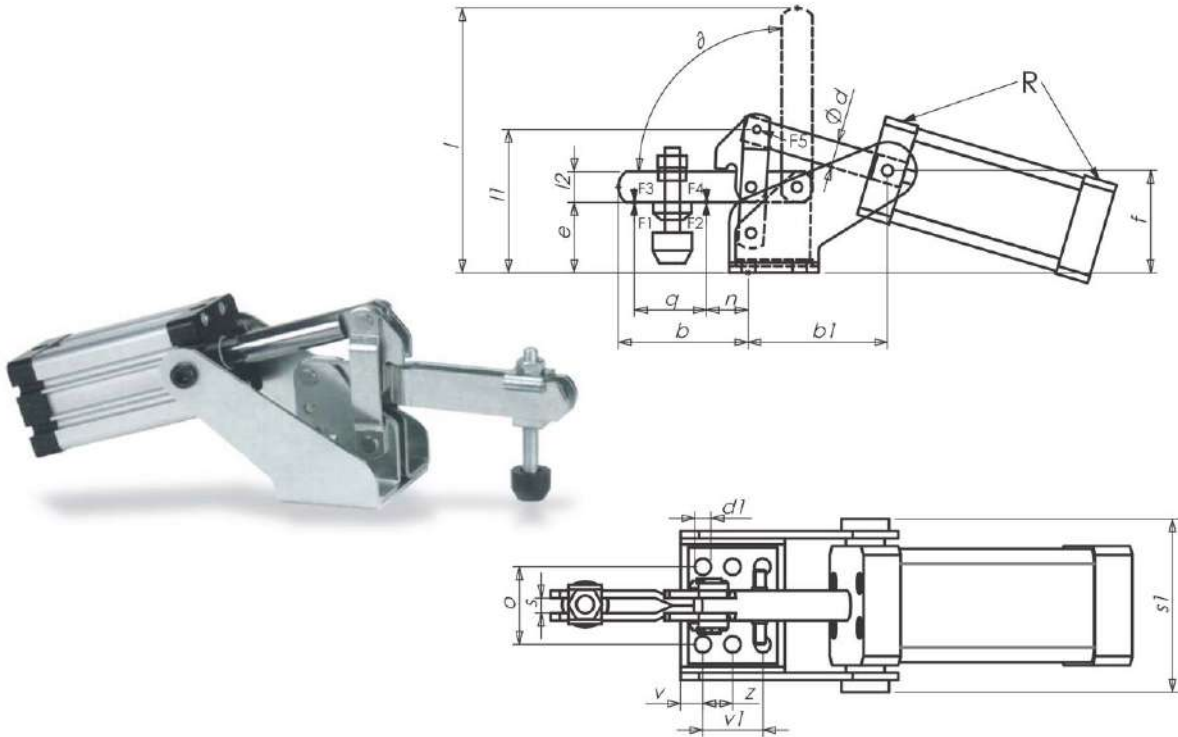

Size	F1*** (kN)	F2 (kN)	F3* (kN)	F4* (kN)	F5 (kN)	hs**				
1	0.8	1.1	0.20	0.3	0.10	0.08	52	175	M5 x 30	610
2	1.0	1.2	0.70	1.0	0.30	0.26	64	200	M6 x 35	870
3	1.4	2.5	0.65	1.1	0.50	0.35	85	250	M8 x 45	1180
4	2.0	3.0	1.50	2.2	0.75	0.80	100	290	M8 x 65	1900

*F3 + F4 = Max. Haltekraft bei 6 bar
**hs = Luftverbrauch für Doppelhub in dm³
***F1 / F2 = Haltekapazitäten

Size	b	b1	d	d1	e	f	l	l1	l2	n	o	s	s1	v	v1	z	q	∅	Strok	Kolbendurchmesser	R
1	38	58	6	4.5	22	32	100	46	10	11	27	5.5	50	8	16	-	19	90°	34	20	M5
2	51	53	12	5.5	27	41	108	57	12	10	26	6.2	62	7.5	20	10	24	90°	42	25	M5
3	80	63	12	7.1	39	56	155	75	18	27	31	8.5	70	7.5	20	-	29	90°	52	32	G1/8
4	100	86	16	8.5	51	64	200	85	20	30	41.5	8.5	84	9	20	17.5	61	90°	62	40	G1/8

Kolbendurchmesser F2 - benötigtes Kolbendurchmesser für die angegebene Haltekraft bei 6 bar

P53 Pneumatischer Kniehebelspanner-Horizontaler Zylinder

P53

Pneumatic toggle clamps

With horizontal cylinder attachment

Fitted with pneumatic cylinder, double-acting anodised, installed and ready to connect. Magnetic piston for end-position monitoring.

With flow-restriction drillings for reduced speed. Clamps are galvanized and passivated. Stainless steel rivets running in case-hardened bushes.* Bearings are pre-lubricated.

Complete with tempered, galvanized clamping screw MS10/20 ve MS10Z

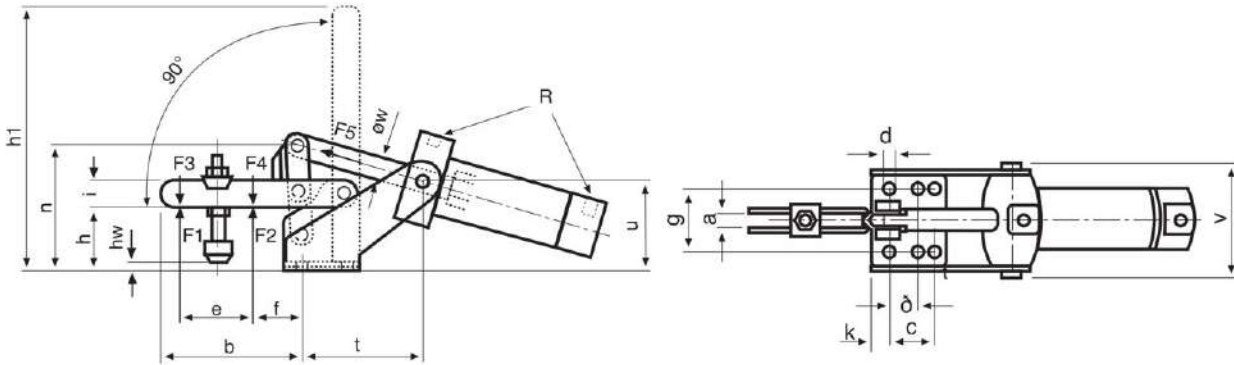

Size	F1*** (kN)	F2 (kN)	F3* (kN)	F4 (kN)	F5 (kN)	hs**				
1	0.8	1.1	0.35	0.5	0.19	0.15	55	195	M5 x 30	630
2	1.0	1.2	0.70	1.0	0.30	0.28	65	220	M6 x 35	800
3	1.4	2.5	0.65	1.1	0.50	0.35	90	250	M8 x 45	1200
4	2.0	3.0	1.50	2.2	0.75	0.80	105	320	M8 x 65	2000

*F3 + F4 = Max. Haltekraft bei 6 bar
 **hs = Luftverbrauch für Doppelhub in dm³
 ***F1 / F2 = Haltekapazitäten

Size	a	b	c	ed	e	f	g	h	h1	hw	i	k	l	n	t	u	v	øw	Strok	Zylinder Kolbenfläche	R
1	5.5	38	16	4.5	19	11	27	22	100	-2-5	10	8	-	46	58	32	50	8	34	16	M5
2	6.2	51	20	5.3	24	10	26	27	108	-1-8	12	7.5	10	57	53	41	62	12	42	25	M5
3	8.5	80	20	7	29	27	31	39	155	2+14	18	7.5	-	75	63	56	70	12	52	32	G1/8
4	8.5	100	34.5	8.5	61	30	41.5	51	200	-5-24	20	9	17.2	85	86	64	84	16	62	40	G1/8

Kolbendurchmesser F2 - benötigtes Kolbendurchmesser für die angegebene Haltekraft bei 6 bar

Pneumatische Kniehebelspanner



P55 Schubstangen-Pneumatikspanner

P55

Push type pneumatic toggle clamp

Heavy version for long working life. Fitted with double-acting pneumatic cylinder with flow-restriction drillings for reduced speed anodised, assembled and ready to connect. Materials: console galvanized and passivated, clamp body is malleable iron casting, painted. Toggle parts and push rod are heat-treated steel, galvanized and passivated. Rivet is stainless steel. Bearings are pre-lubricated.



Size : 5,7

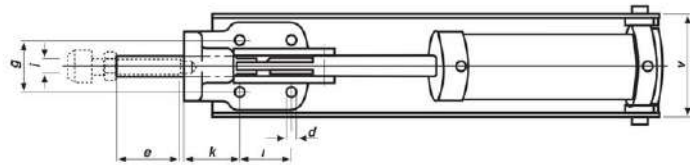
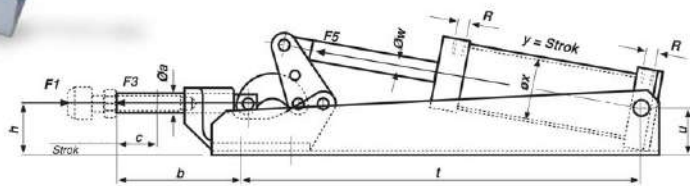

Size : 3

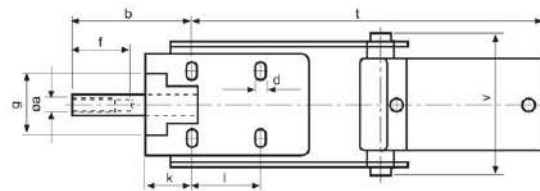
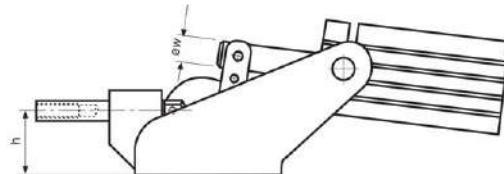

Size	F1*** (kN)	F2 (kN)	F3* (kN)	hs**			
3	4.0	2.5	0.75	0.8	85	320	M8 x 35 2000
5	10.0	5.0	1.0	2.2	115	450	M12 x 50 3500
7	25.0	10	1.0	4.5	150	533	M12 x 50 7680

*F3 + F4 = Max. Haltekraft bei 6 / Max. Holding capacity at 6 bar
**hs = Luftverbrauch pro Doppelhub bei 6 bar (dm³) / Air consumption per double stroke at 6 bar (dm³)
***F1 / F2 = Haltekraft

Size	øa	b	c	ød	e	f	g	h	i	k	l	t	u	v	øw	ex*	Strok y	R
3	12	70	20	6.5	30	94.5	36	35	M8	28	40	210	62	74.5	16	40	100	G 1/8
5	16	86	29	8.5	45	125	54.5	45.5	M12	45	75	334	37.5	83	16	50	100	G 1/8
7	22	105	36	11	50	125	54.5	59	M12	44	101	450	49	112	16	63	125	G 1/4

Kolbendurchmesser x = F5 : Notwendiges Zylinderdurchmesser für die eingetragene Kraft bei 6 bar

P60 Schwerer Pneumatikspanner-Horizontaler Zylinder

P60

Heavy pneumatic toggle clamp

With horizontal cylinder attachment
With swivel mounting and adjustable end position cushioning.
Magnetic piston for end position monitoring.
Tempering steel, burnished.
The axle bolts running in bearing bushes are tempered, ground and locked with circlips.
Clamp is ready for installation and consists of:
Toggle clamp element P61

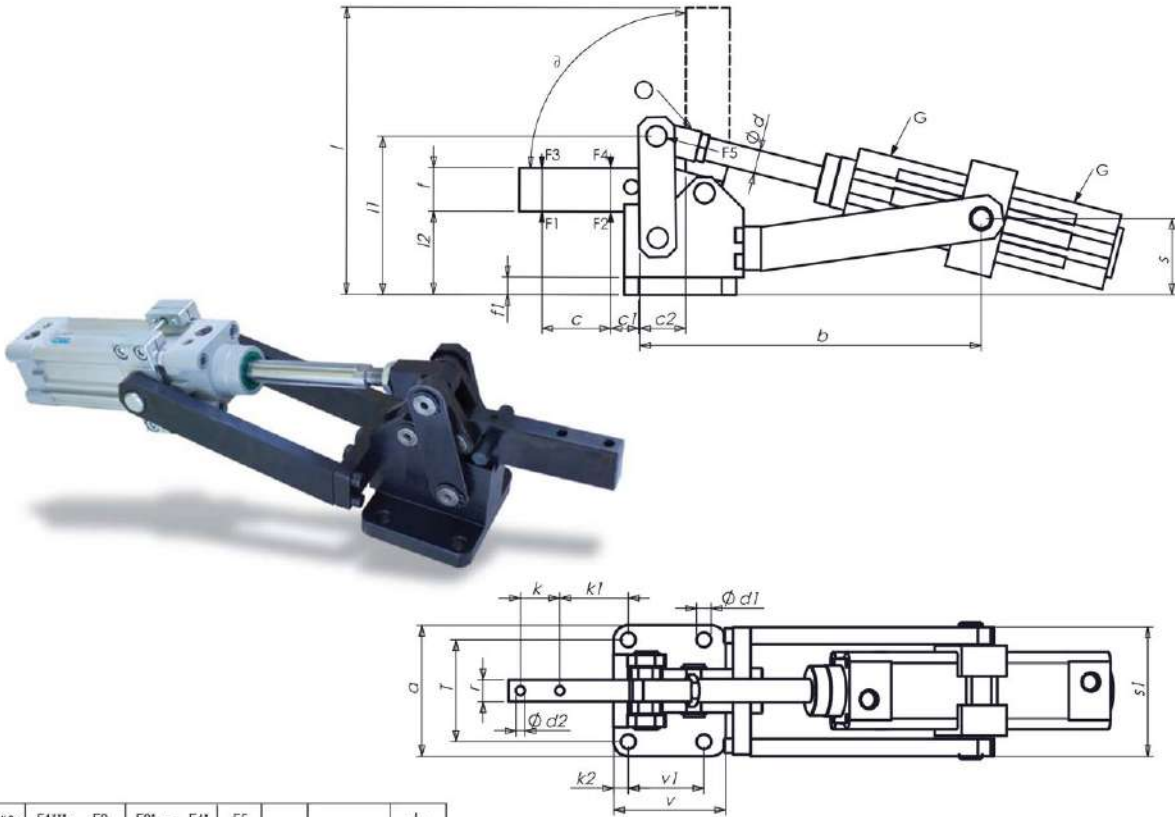

Größe Size	F1*** (kN)	F2 (kN)	F3* (kN)	F4* (kN)	F5 (kN)	hs**		
4	6	9	1.5	2.2	0.75	1.0	122 416	5500
6	12	18	2.5	3.5	1.00	1.8	147 480	7800
8	20	30	4.0	6.0	1.80	4.3	196 580	17800

*F3 + F4 = Max. Haltekraft bei 6 / Max. Holding capacity at 6 bar
**hs = Luftverbrauch pro Doppelhub bei 6 bar (dm³) / Air consumption per double stroke at 6 bar (dm³)
***F1 / F2 = Haltekraft

Größe/Size	a	b	c	c1	c2	d	d1	d2	f	f1	r	k	k1	k2	d	l	l1	l2	s	s1	T	v	v1	∅	Zylinder/cylinder Strok HUB	Koben- Anschrauber	G
4	90	235	54	20	32	16	11	6.2	30	12	15	27	47	10	M6	76	109	57	53	87.5	70	77	52	90°	80	40	G1/4
6	105	280	60	21	30	20	11	8.2	40	12	30	26	53	11	M8	97	129	61	55	101	83	85	55	90°	100	50	G1/4
8	135	320	95	22	47	20	13	8.7	60	12	30	40	69.5	12.5	M12x12.5	198	176	86	78	114.5	111	112.5	80	90°	120	63	G3/8

Kobendurchmesser x = F5 - Notwendiges Zylinderdurchmesser für die angegebene Kraft bei 6 bar



P61 Mechanik-Element für Pneumatikspanner P60

P61

Toggle clamp element

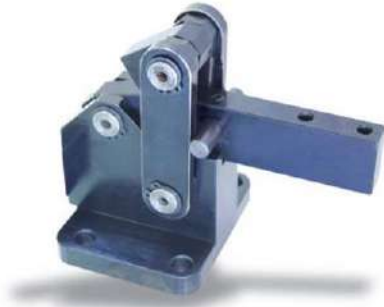
Matching with heavy pneumatic toggle clamp, with horizontal cylinder attachment P60
Tempering steel, burnished.
The axle bolts are tempered, ground and locked with circlips.
Dimension table as for P60



Größe Size	F1** (kN)	F2 (kN)	F3* (kN)	F4* (kN)	F5 (kN)			
4	6	9	1.5	2.2	0.75	122	154	2535
6	12	18	2.5	3.5	1.00	147	169.5	4215
8	20	30	4.0	6.0	1.80	196	240	10670

*F3 + F4 werden mit einem Zylinder Kolbenkraft F5 angeschlossen erreicht /
*F3+F4 can be achieved with a cylinder with the piston force F5.

**F1 / F2 = Haltekraft / Holding capacity

DESETEC SPANNTECHNIK
SPANNWERKZEUGE UND NORMALIEN

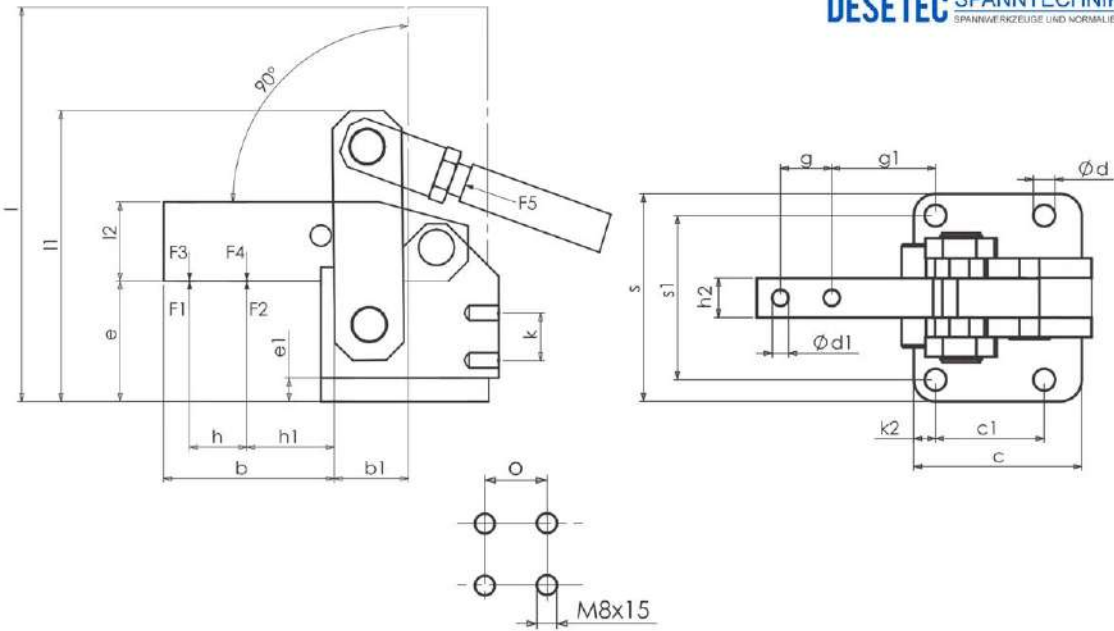

Größe/Size	b	b1	c	c1	d	d1	e	e1	g	g1	h	h1	h2	k	k1	l	l1	l2	o	s	s1
4	82	32	77	52	11	6.2	57	12	27	47	54	20	15	20	10	197	122	30	18	90	70
6	90	30	85	55	11	8.2	61	12	26	53	60	22	20	24	11	215	147	40	24	105	83
8	127.5	47	112.5	80	13	13.0	86	12	40	69.5	95	24.5	30	40	12.5	306	196	60	34	136	111

P62 Schwerer Pneumatikspanner-Vertikaler Zylinder

P62

Heavy pneumatic toggle clamp

With vertical cylinder attachment

Tempering steel, burnished. The axle bolts running in bearing bushes are tempered, ground and locked with circlips.

With magnetic piston for end-position monitoring.

The clamp is ready for installation.

With double-acting pneumatic cylinder.

Toggle clamp element P63

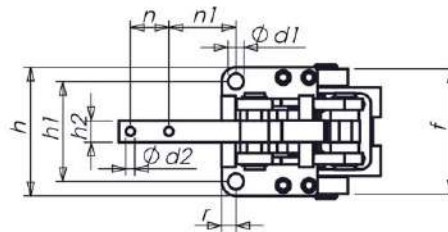
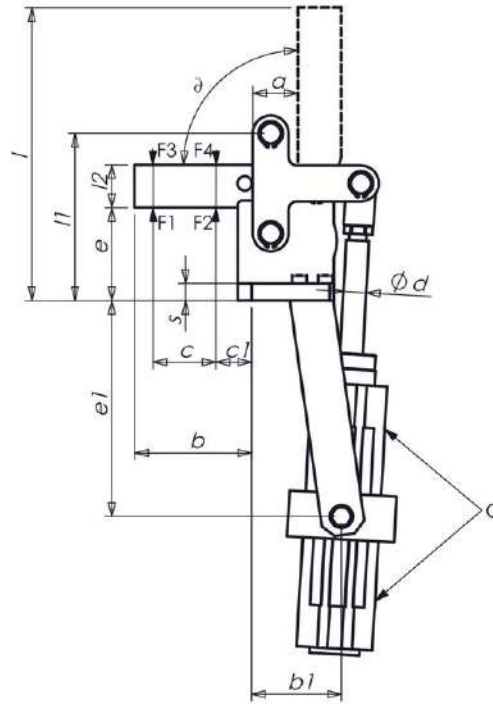

Größe Size	F1*** (kN)	F2 (kN)	F3* (kN)	F4* (kN)	F5 (kN)	hs**			
4	6	9	1.5	2.2	0.75	1.0	172	340	5100
6	12	18	2.5	3.5	1.00	1.8	195	286	72500
8	20	30	4.0	6.0	1.80	4.3	272	470	16800

*F3 + F4 = Max. Haltekraft bei 6 bar / Max. Holding capacity at 6 bar
 **hs = Luftverbrauch pro Doppelhub bei 6 bar (dm³) / Air consumption per double stroke at 6 bar (dm³)
 ***F1 / F2 = Haltezeit

Größe/Size	a	b	b1	c	c1	d	d1	d2	e	e1	f	h	h1	h2	l	l1	l2	n	n1	r	s	t	u	∂	Zylinder/cylinder Stroke PLUB Kolben- diameter	G	
4	32	82	46	54	20	16	11	6.2	57	193	90	90	70	15	206	117	30	27	47	10	12	46	193	90°	74	40	G1/4
6	29	91	48	60	22	16	13	8.2	69	221	100	107	83	20	226	137	40	26	54	12	15	48	221	90°	87	50	G1/4
8	45	125	77	95	24.5	16	17	13.2	94	255	123	145	115	30	318	184	60	40	67	15	20	77	255	90°	120	63	G1/4

Kolbendurchmesser x = F5. Notwendiges Zylinderdurchmesser für die angegebene Kraft bei 6 bar

P63 Mechanik-Element für Pneumatikspanner P62

P63

Toggle clamp element

Matching with heavy pneumatic toggle clamp, with horizontal cylinder attachment P62
Tempering steel, burnished.
The axle bolts are tempered, ground and locked with circlips.
Dimension table as for P62

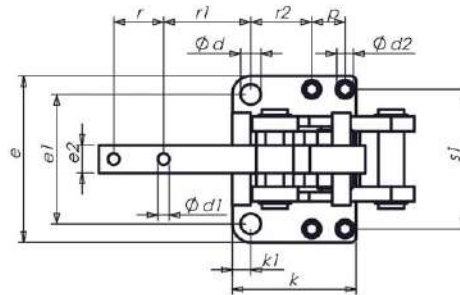
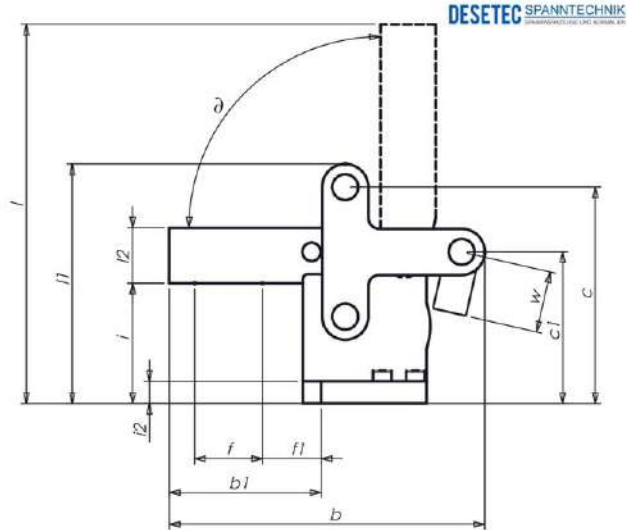

Größe Size	F1** (kN)	F2 (kN)	F3* (kN)	F4* (kN)	F5 (kN)			
4	6	9	1.5	2.2	0.75	130	172	2400
6	12	18	2.5	3.5	1.00	155	200	4300
8	20	30	4.0	6.0	1.80	204	265	11000

*F3 + F4 werden mit einem Zylinder Kolbenkraft F5 angeschlossen erreicht /
*F3+F4 can be achieved with a cylinder with the piston force F5

**F1 / F2 = Haltekraft / Holding capacity

Größe/Size	b	b1	c	c1	d	d1	d2	e	e1	e2	f	f1	l	l1	l2	p	r	r1	r2	s	w	alpha				
4	172	82	117	82	11	6.2	6.5	90	70	15	54	20	65	12	67	10	206	130	30	18	27	47	33	75.5	29.5	90°
6	200	91	137	92	13	8.2	6.5	107	83	20	60	22	69	15	73.5	12	226	155	40	24	26	54	29.5	87.5	37	90°
8	265	125	184	124	13	13.2	6.5	145	115	30	95	24.5	94	20	109	15	318	204	60	40	40	67	44	102.5	32	90°

H12 Hydraulischer Hebelspanner

H12

Hydraulic link toggle clamp - Double acting

Cylinder housing is made of high-strength black casting.

Piston rod case-hardened and chrome plated.

Wiper piston rod. Pin made of tempering steel. Integrated, adjustable restrictor.

Clamp arm included.

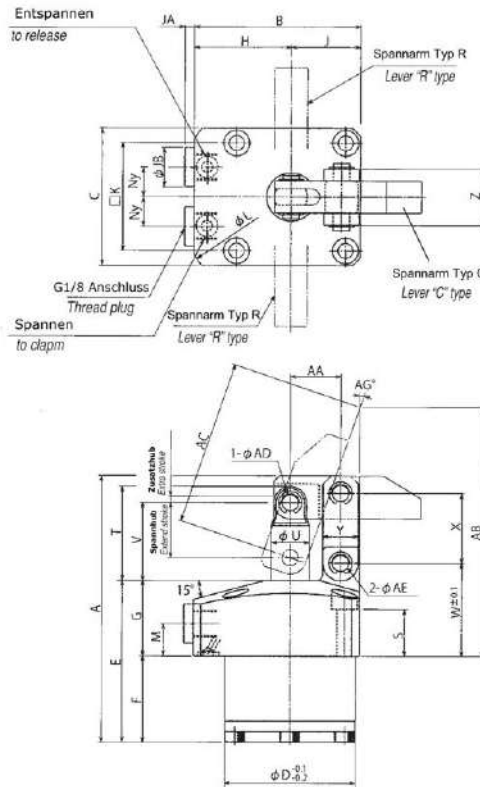

ANSCHLUSSMASSE
Dimensions of mounting area

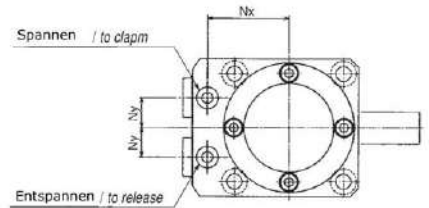
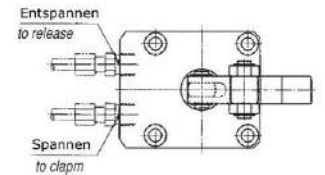
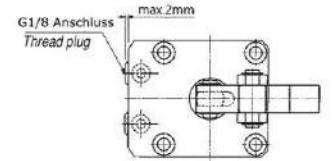
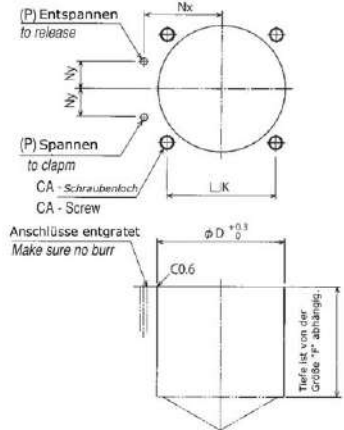

Größe Size	Gesamthub Full stroke	Spannhub Extend stroke	Zusatzhub Extra stroke	Max. Betriebsdruck Max. operating pressure	Min. Betriebsdruck Min. operating pressure	Max. zul. Belastungsdruck Max. withstanding pressure	Medium Usable fluid	Betriebstemperatur Operating temperature	g
24	18.5	16	2.5	7.0 mpa	0.5 mpa	10.5 mpa	Öl - oil	0 - 70°C	600
30	23.5	20.5	3	7.0 mpa	0.5 mpa	10.5 mpa	Öl - oil	0 - 70°C	800

Größe/Size	A	B	C	D	E	F	G	H	J	K	L	M	Nx	Ny	P	Q	R	S	T	U	V	W	X	Y	Z	AA	AB	AC	AD	AE	AG	CA	JA	JB
24	78.5	49	40	36	48	23	25	29	20	31.4	66	11	23.5	8	3	7.5	4.5	15.5	27	10	22.5	30	20	11	19	14.5	74.3	47.3	5	5	19.6	M4x0.7	3.5	14
30	100	61	51	48	60	32	28	35.5	25.5	40	81	12	30	11	3	9	5.5	16	35	14	29	34.5	26	13	24	18.5	92.4	61.2	6	6	18.9	M5x0.8	3.5	14

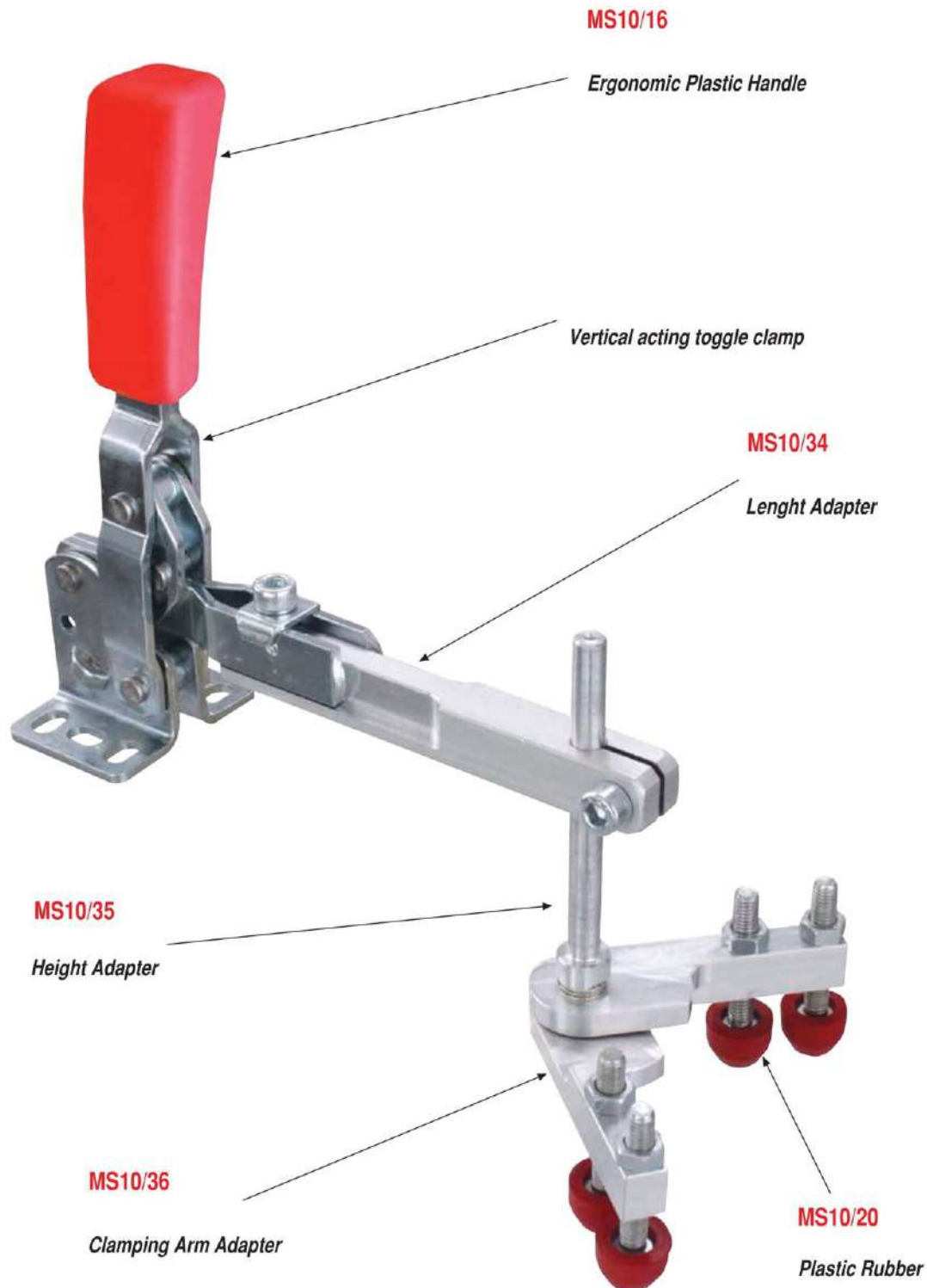
MS10 Schnellspanner - ZUBEHÖR

MS10 Schnellspanner - ZUBEHÖR

MS10/34

Lenght Adapter

Size	B	B1	B2	B3	B4	eD	eD1	eD2	L	L1	L2	L3	L4	M	M1
2	12	6.5	9	12	2x45°	5.5	10	6	95	70	15	48	6	M5	M5
3	15	9	12	15	2x45°	5.5	10	6	95	70	15	78	6	M5	M5

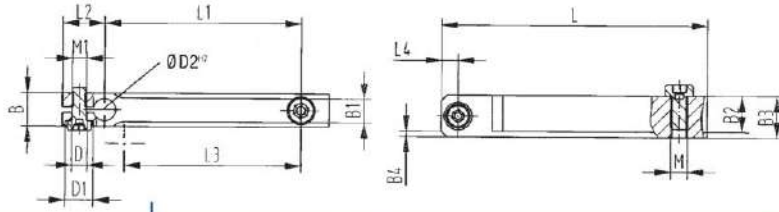

MS10/36

Clamping Arm Adapter



Size	B	B1	B2	B3	B4	B5	eD	L	L1	L2	L4	L5	L6	M	M1
2-3	10	6	20	8	12	92	6	60	51	32	15	15	10	M5	M5

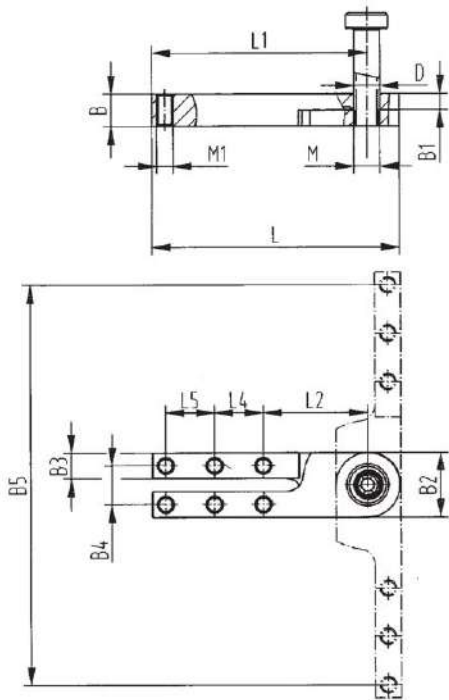

MS10/32

Arm Extension



Size	B	B1	B2	B3	B4	L	L1	L2	L3	L4	L5	L6	M	M1
2	12	6.5	9	12	2x45°	127	110	35	48	15	75	10	M5	M5
3	15	8.5	12	15	2x45°	167	150	45	73	15	105	10	M5	M5
4	17	9	16	20	2x45°	220	200	45	73	15	105	10	M8	M8

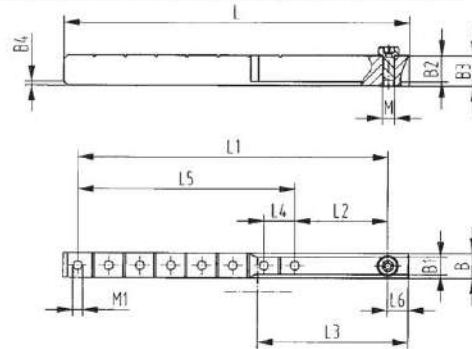

MI0/35

Height Adapter



Size	eD	eD1	eD2	L	L1	L2	L3	SW	M
2-3	10	6	6	52 82	35 65	8	12	8	M6

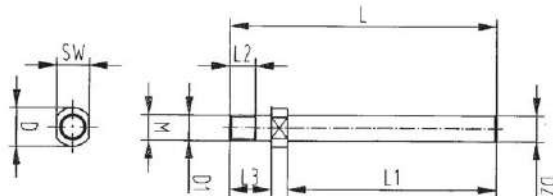

Schnellspanner - ZUBEHÖR

MS68/I

Toggle Clamp for Stand

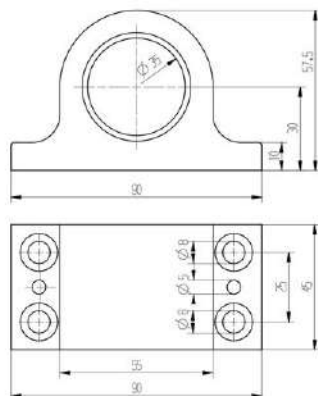

MS60/I

Toggle Clamp for Stand

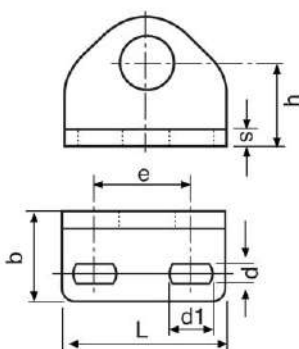

Size	d	d1	e	L	b	h	s
0	4.5	4.5	16	25	16	12	2.5
1	4.5	6.5	17.5	30	20	15.5	3
2	5.5	8	34	50	28	22	4
3	6.5	12	36	60	31.5	26	5
5	8.5	17	37	65	36	30	6

PS20/4

Clamp arm

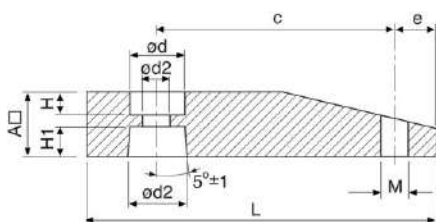

Size	A	H	H1	C	L	e	od	od1	od2	M
32	20	8	9	59	80	9.5	13.5	15.5	8.5	M8
40	19	8	9	64	90	14.5	13.5	15.5	8.5	M8
50	25	10.5	10	78.5	105	9.5	17	19.5	11	M12
63	25	9	10	90	115	9.5	19	19.5	11	M12

Fitting and removing clamping arm



Fitting clamping arm

Hold clamping arm with spanner. Tighten /loosen screw

Removing clamping arm

Loosen clamping arm from piston rod.

Caution : Do not strike sides of clamping arm.

Schnellspanner - ZUBEHÖR

MS46/I



Counter catch
Galvanized and passivated.
Bushes case hardened and
greased; rivets of stainless steel.

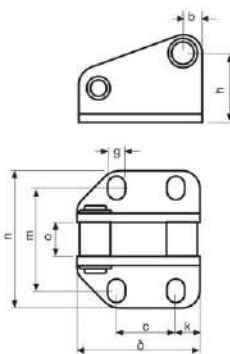

Size	b	c	h	g	k	l	m	n	o
1	6	19	22.5	4.5	6	31	28	41	6.8
3	6	19	23.0	5.5	13	31	32-35	46	10.8
5	12	29	49.0	11.0	13	31	60	89	13.7

MS46K/I



Counter catch
Galvanized and passivated.
Bushes case hardened and
greased; rivets of stainless steel.

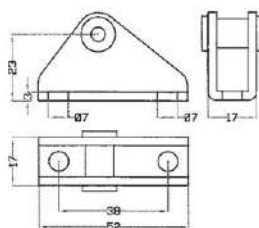

MS40/5



Counter catch
Galvanized and passivated.
Bushes case hardened and
greased; rivets of stainless steel.

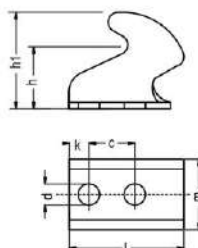

Size	d	c	k	l	m	h	h1
1	4.5	10	5	20	13.5	12	17.5
2	5.5	11	7.5	26	16	15	20
3	6.5	14	6	35	21.5	19	29
4	8.5	19	8	47	28	25	39

MS40S/I



Counter catch
Galvanized and passivated.
Bushes case hardened and
greased; rivets of stainless steel.

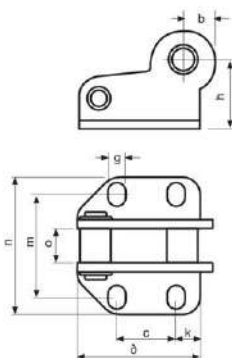

Size	b	c	h	g	k	l	m	n	o
3	6	19	24	5.5	13	41	32-35	43	6.8

Schnellspanner - ZUBEHÖR

MS44/3

Counter catch

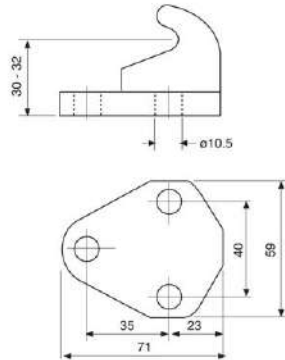

MS52/3

Counter catch
Galvanized and passivated.
Bushes case hardened and
greased; rivets of stainless steel.

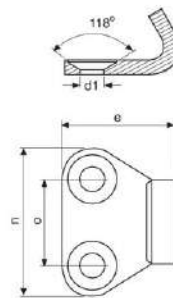

Size	d1	n	e	o
2	4.3	25	21	14
4	5	30	23	17

MS50/3

Counter catch
Galvanized and passivated.
Bushes case hardened and
greased; rivets of stainless steel.

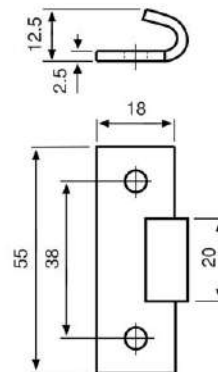

Schnellspanner - ZUBEHÖR

MS46/3

Catch

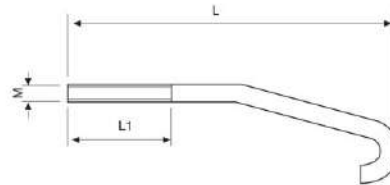

Size	M	L1	L
1	M6	30	86
3	M8	50	142
5	M12	107	186

MS40/4

Catch

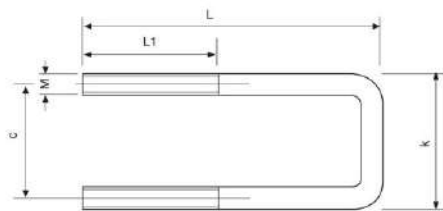

Size	L	L1	c	k
M4	55	25	19	23
M4	83	52	24	28
M5	85	40	25	30
M6	112	67	31	37
M8	146	87	42	50
M10	130	60	44,5	54,5
M10	170	80	54	64

MS52/4

Catch

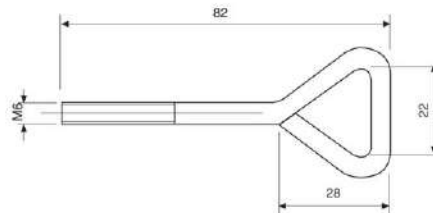

MS50/5

Catch

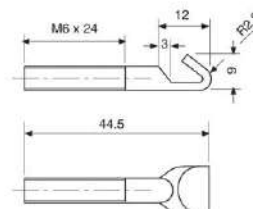



Schnellspanner - ZUBEHÖR

MS10/20

Clamping Screws
Stainless Steel



**Gummifuß leer
Kann an die
Andrückschraube
montiert werden.**

Size		h	L	 g
0	M4 x 25	18,5	31	7,70
1	M5 x 30	22	38	13,80
2	M6 x 35	25	43	19,80
3+4	M8 x 45	29	57	44,20
	M8 x 65	47	77	63,30
5	M12 x 80	56	97	165,40

Auf Wunsch auch in rostfreiem Stahl produzierbar !



**Gummifuß leer
Kann an die
Andrückschraube
montiert werden.**



**Gummifuß voll,
bildet eine Einheit mit
der Andrückschraube .**

Schnellspanner - ZUBEHÖR

MS10/22

Clamping Screw
Stainless Steel

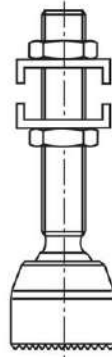

MS10/23

Clamping Screw
Stainless Steel

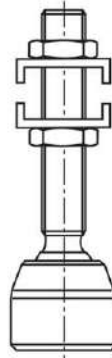

MS10/24

Clamping Screw
Stainless Steel

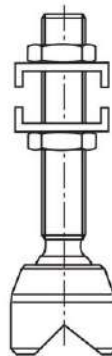

Size		A	B	C
2	M6	53.5	13	ø16
3	M8	64.5	17	ø20
4	M10	86	21	ø26.5
5	M12	98	24	ø30

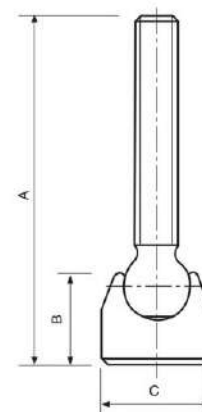

Schnellspanner - ZUBEHÖR

MS10/16

Plastic Handle

MS10/16E



Size : (0 - 4)

MS10/16C



Size : (5, 5+7)

MS10/16Y



Size : (0 - 5)

MS10/15

Plastic Rubber Nose

Of oil resistand rubber to prevent damage to delicate components.



Size				
0	M4	11	8.5	1
1	M5	12	9	1
2	M6	15	11.5	2
3	M8	19	14	4
4	M10	24	17	6
5	M12	25	20	8

MS10/30

Supporting arm for toggle clamps

Galvanized and passivated, complete with two clamping screw no.891 and fastening screw.

Size				
1	M5 x 30	22 - 72	85	65
2	M6 x 35	28 - 85	100	90
3	M8 x 45	34 - 100	120	200
4	M8 x 65	40 - 125	150	370
5	M8 x 65	40 - 125	150	370

Part no. of toggle clamps	Size						
	0	1	2	3	4	5	6
M10	-	1	2	3	4	-	5
M11	-	1	2	3	4	-	5
M12	-	1	2	3	4	-	5
M20	-	1	2	3	4	5	-
M21	-	1	2	3	4	5	-
M22	-	-	-	3	-	-	-

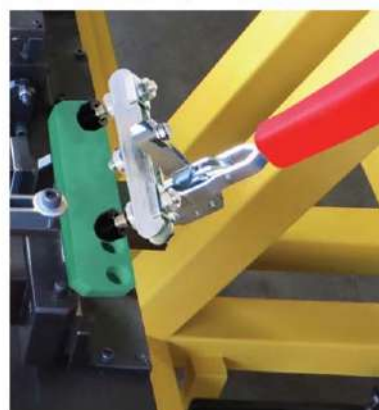
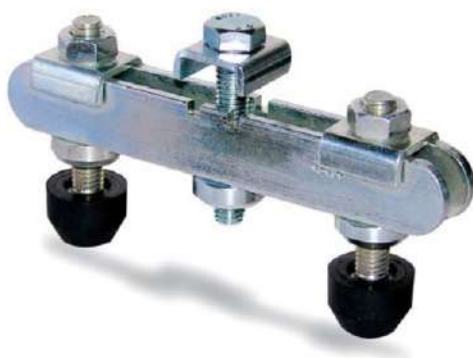

Ersatzteile, Vorrichtungen und Formenbau im Kundenauftrag

spare parts.. moulds.. some of our speciales

