



Our strength:  
Water Treatment

DEWEKON ENGINEERING  
ONDERNEMINGENSTRAAT 11  
8630 VEURNE  
INFO@DEWEKON.BE  
WWW.DEWEKON.BE



# CABLE SCREEN

The cable screens designed by **Dewekon Engineering** consist of:

- The frame is a welded plate-construction, calculated to resist the highest water level ahead of the screen.
- Guiding profiles to guide the scraper mechanism.
- The screen bars have a hydrodynamic section, to prevent the screen from clogging, and to create a minimum of hydraulic loss through the screen.
- A backplate above the bars to bring out the screened waste.
- The scraper is lifted by one or two cables, depending on the width of the screen.
- The scraper is guided by 4 wear resistant wheels. They have a grease point.
- The drive unit is on top of the screen frame. It consists of the main driving shaft and one or two cable drums, driven by a motor gearbox.
- The drive unit is a hermetical closed oil-bath gearbox with brake motor.
- The scraper goes down in "open" position at a distance of 40cm from the screen surface.
- When the scraper arrives in the lower position it closes slowly. The speed of closing the scraper is adjustable.
- The teeth penetrate between the bars, and the screenings are moved upwards.
- The teeth of the scraper are replaceable.
- The positions at the top and bottom are detected by a limit switch, next to the gearbox.
- The movement downwards of the scraper is protected by a "slack rope detection".
- During the rise of the scraper the mechanism is protected by a torque limiter (option).
- The screen is equipped with all safety devices according to the European CE directive.

Aligement	Vertically	Inclined
Inclination	90°	80°
Channal depth	1...20m	
Useful width	300...4000mm	
Bar spacing	10,15,20,25,30,40,50,60,80,100mm	



# 3-CABLE SCREEN

The 3-cable screens designed by **Dewekon Engineering** consist of:

- The frame is a welded plate-construction, calculated to resist the highest water level ahead of the screen.
- Guiding profiles to guide the scraper mechanism.
- The screen bars have a hydrodynamic section, to prevent the screen from clogging, and to create a minimum of hydraulic loss through the screen.
- A back plate above the bars to bring out the screened waste.
- The scraper is lifted by two cables.
- The scraper is guided by 4 wear resistant wheels. They have a grease point.
- The drive unit is on top of the screen frame. It consists one motor gearbox for lifting the scraper unit and one for opening and close the scraper.
- The drive unit is a hermetical closed oil-bath gearbox with brake motor.
- The scraper goes down in "open" position at a distance of 40cm from the screen surface.
- When the scraper arrives in the lower position or when it touches an obstruction it closes slowly.
- The teeth penetrate between the bars, and the screenings are moved upwards.
- The teeth of the scraper are replaceable.
- All movements downwards of the scraper are protected by a "slack rope detection".
- During the rise of the scraper the mechanism can be protected by a torque limiter.
- The screen is equipped with all safety devices according to the European CE directive.
- The advantage of this 3-cable screen is the possibility that the scraper can close at each position. So he can dig a way through the waste.

Inclination	90°
Channal depth	1 tot 20m
Channal width	600 tot 2500mm
Bar spacing	10,15,20,25,30, 40,50,60,80,100mm

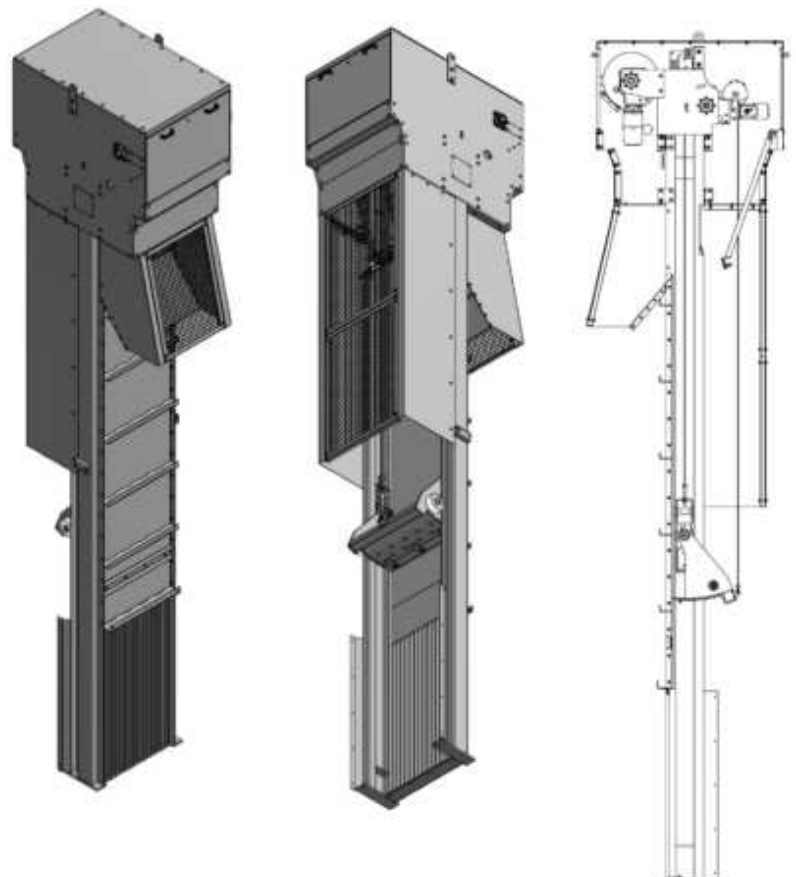

# CHAIN SCREEN

- A rigid frame, composed of U-sections with transverse reinforcements. It is a fully welded construction.
- Guiding profiles are welded on the chassis for the wheels.
- The grill consists of a number of parallel bars. For grids up to 20mm bar spacing a hydrodynamic section applied. For more than 20mm the bars are rectangular. They are reinforced to eliminate distortion.
- The rake moves down in open position. In the lower position the rake moves towards to the grate bars. The teeth of the rake penetrate between the bars.
- The solids are moved along the bars; on a guiding plate they are moved to the surface.
- When the rake is in upper position the solids are pushed back with a scraper. All movements are smoothly without shocks or any noise.
- The rake is powered by two rigid chains. The chains are guided by rollers. There are no moving parts under the water level.
- The rake is driven by a hermetically sealed IP55 gear motor.
- In case of overload, the movement of the rake is stopped by means of a torque limiter.
- The screen is built-in vertically or at an angle of 10 to 20° to the vertical.
- The entire screen is secured to the CE regulations.
- The screen is fully automatic. The cleaning cycle can be set with a time clock or with a difference in level measurement.



# CHAIN SCREEN TYPE 2

- A rigid frame, composed of U-sections with transverse reinforcements.
- The screen pack consist of a number of parallel bars. A hydrodynamic profile is used for gratings of 10 mm bar spacing. The bars above are rectangular. They are strengthened sufficiently to prevent distortion.
- Ideal for narrow channels with limited space.
- The scraper bars lower due to the conduction of the chain. When the scraper bars come down, they take the grate up with them. The teeth of the slats penetrate between the bars.
- The grid is brought up along the bars and a guide plate.
- When the scraper bars coming above the grid well is removed by a doctor blade of the scraper bars. All movements happen gradually without jerks to work quietly.
- The scraper bars are driven by two heavy chains. The chain is guided by rollers.
- The bars are driven by a hermetical closed geared motor IP55.
- In case of overload, the motion of the scraper bars is stopped by means of an electronic torque limiter (optional).
- The screen is installed at an angle of 10 to 20 ° with the vertical.
- The installation works fully automatically. The cleaning cycle can be set with a timer or with a level difference measurement.
- The entire installation complies with the applicable CE regulations.



# STEP SCREEN

The fine screen of the type «step» is designed to remove solids from the sewage.

The surface of the grid consists of a package of parallel blades. They are inclined at an angle of 55 degrees. This package consists of 2 groups of blades:

- The fixed blades (pair blades)
- The movable blades (odd blades)

The shape of the blades is designed to accumulate the screenings on the grate surface.

The circular moving blades bring the screenings step by step to the upper point of the blade package.

The movement of the blade package is originated with the aid of a chain.

The blades are replaceable one by one, without removing all the blades.

The package moving blades always stops at the same point by means of a inductive sensor.

The stop position of the blades is adjustable with a brake motor.

The geared motor is optionally provided with a heating resistor to avoid condensation.

The step screen is optionally protected with a torque limiter.



Specifications	
Channel width	625,...1500mm
Distance between bars	3 of 6mm
Thickness of bars	3mm
Installation angle	55°
Materials	SS304, optional SS316



# CURVED SCREEN

- The bars package consists of concentric curved bars.
- The lower part of the bars is specially profiled to minimize the accumulation of solids.
- Rotating arms with toothed scraper bar brings up the solids.
- The scraper bar is mounted on a with self-aligning bearings shaft.
- The scraper is mechanically designed to prevent blockage.
- If the resistance is yet to large, the movement will be stopped by a torque limiter.
- The scraper is driven by a hollow shaft geared motor.
- When the scraper is in upper position, the solids are sheared off by a hinged wiper.
- The scraper has a plastic abrasion profile.
- The bars package and the scraper bars are fixed on a frame.
- The unit is aligned and tested at the factory.

Specifications	
Channel width	0,30,.....2m
Channel depth	0,30,.....1,50m
Distance between bars	10,20,30,40,50mm
Materials	AISI304, AISI316

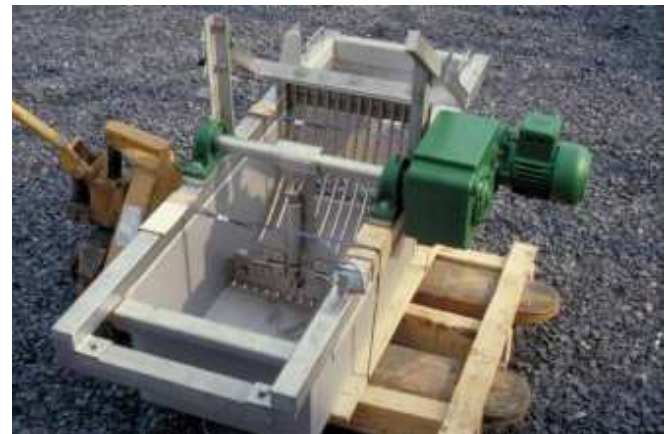

# STATIC CURVED SCREEN

The static curved screen is a simple mechanical filter. The filter surface has a curved or parabolic surface. The advantage of this shape is that the suspended solids, which are sieved from the water, will slide down the parabolic surface and are collected in a container. Water will go through the parabolic surface and is collected in the bottom of the sieve.

The curved screen is optionally provided with a cover with gas springs and with a spraying system.

### Advantages:

- Continuous separation,
- Minimal maintenance costs,
- Low noise.

Type	Nominal capacity [m <sup>3</sup> /h]				Useful width	Inlet	Exhaust
	Slot between the wire bars						
	0,25 mm	0,5 mm	1 mm	1,5 mm			
300	12	18	25	30	300	NW 100	NW 100
600	24	36	50	60	600	NW 100	NW 100
1000	40	60	84	100	1000	NW 150	NW 200
1200	48	72	100	120	1200	NW 150	NW 200
1500	60	90	125	150	1500	NW 150	NW 200
1800	72	108	150	180	1800	NW 200	NW 250
2000	80	120	168	200	2000	NW 200	NW 250

Other types can be customized

The indicated flows depend on the main characteristics of the outflow, like: Solids concentrations, viscosity, temperature, etc.....

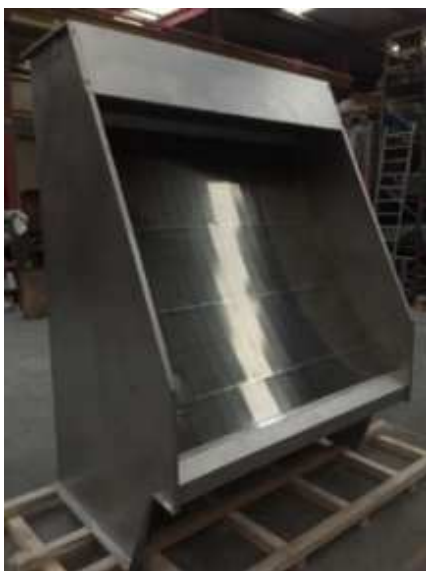



# SAND TRAP BRIDGE RECTANGULAR

## General:

- Welded frame with a minimum width of 0,80m;
- Hand railings:
  - Upper bar, height 1,10m above tread;
  - Intermediate bar at half height;
  - Plinth, height 150mm, according to ARAB;
- 4 wheels with 2 drive wheels;
- One or more air lift pipes;
  - One or more motorized surface scrapers;
- Galvanized gratins for an overload of 300kg/m<sup>2</sup>;
- Limit switches, torque-limiter, obstacle detection, wheel slip detection, emergency stop.



## Standard materials:

- Bridge: steel, with surface protection:
  - Sandblasting SA 2 ½;
  - Zinc spraying;
  - Epoxy paint 2 layers;
  - Standard color: Emerald green, RAL6001
- All parts in contact with water: AISI 304.



## Electrical equipment:

- Obstacle detection;
- Wheel slip detection;
- Emergency stop;
- Complete cabling on the bridge.



# SAND TRAP BRIDGE CIRCULAR

## General:

- Welded frame with a minimum width of 0,80m;
- Hand railings:
  - Upper bar, height 1,10m above tread;
  - Intermediate bar at half height;
  - Plinth, height 150mm, according to ARAB;
- One air lift pipe;
- One or more surface scrapers;
- Galvanized gratins for an overload of 300kg/m<sup>2</sup>;
- Emergency stop and torque-limiter.



## Standard materials:

- Bridge: steel, with surface protection:
  - Sandblasting SA 2 ½;
  - Zinc spraying;
  - Epoxy paint 2 layers;
  - Standard color: Emerald green, RAL6001
- All parts in contact with water: AISI 304.



## Electrical equipment:

- Emergency stop;
- Complete cabling on the bridge.

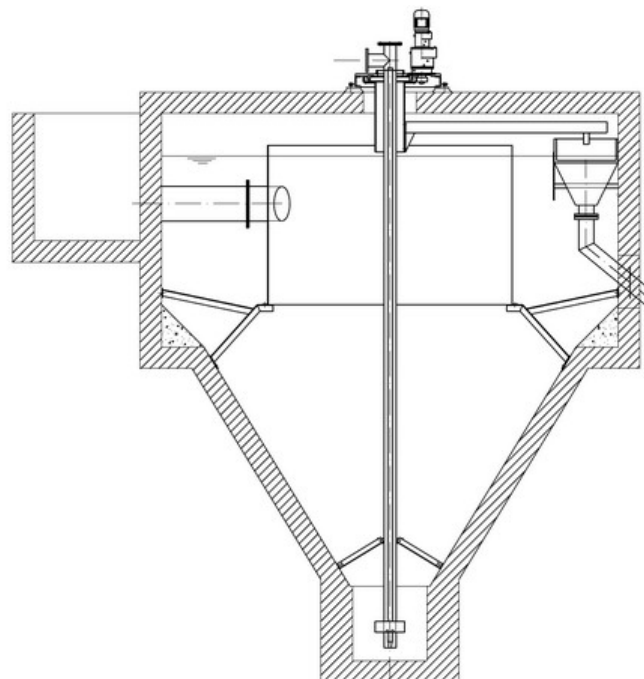

# AIRLIFT

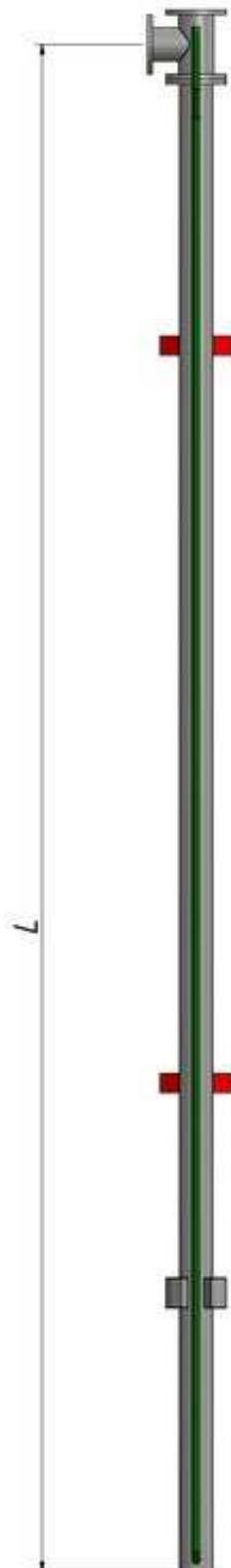

*Air/water  
to unclog  
min. 3bar*

*Air supply*



Main pipe	Air supply	Unclog pipe
DN100	1"	1"
DN150	5/4"	5/4"
DN200	6/4"	6/4"
Material : SS304/316		
L=3...7m		



# GRIT CLASSIFIER

Type: shaft less screw

- Sedimentation tank in rigid plate welded construction.
- Inlet zone with baffle to prevent short-circuit water current.
- Inlet and outlet flange adapted to the flow.
- The trough is equipped with hardened steel rails.
- The shaft less screw is made of a 20mm thick spiral of special high wear-resistant steel.
- Inclination: 25°.
- The end of the screw is coupled by a support, bolted to the gearbox.
- The screw is driven by a hollow shaft motor-reducer.
- The reducer is fixed to the trough by a support plate.
- The reducer can be removed without disassembling the screw.
- The trough is covered by a bolted cover plate.
- The screw is equipped with inlet and outlet hoppers, and is entirely closed.
- The screw is made of special hard steel to resist to the maximum wear of friction.
- The supports are adapted to the local circumstances, according to description in the offer.

Materials:

- Sedimentation tank, trough, covers, supports: AISI304,
- Spiral: special high resistant steel,
- Drive shaft: Steel P335

Models			
Type	Sand-water mixture [m <sup>3</sup> /h]	Volume [m <sup>3</sup> ]	Surface [m <sup>2</sup> ]
		To overflow gutter	
ZKL30	30	0,55	1,30
ZKL70	70	1,16	2,30
ZKL150	150	2,57	3,70
Larger types up to 6m <sup>3</sup> are customized			



# GRIT CLASSIFIER

## Type: scraper type

- The construction consists of:
  - A steel storage room, thickness 5mm;
  - 1 supply opening;
  - 1 overflow tube;
  - 1 drain connection, with stop plug.
- In this tank, there is a scraper mechanism placed, that consist of:
  - A hermetic worm gear motor with degree of protection IP55;
  - A drive rod with ball bearings;
  - Two swing bases, each consisting of two swing arms, each with 2 ball bearings.
  - Two rocker levers, of which one is connected to the connecting rod;
  - A drawbar that connects the rocker levers;
  - A frame with 2 flange connections that are attached to the rocker levers. The frame consists of 2 longitudinal bottom H-profiles, on which every 15cm the scraper blades are welded. The thickness of the scraper blades is 6mm.
- 4 supports each with a foot plate 30x30cm. Each foot plate has 4 holes to fix the structure to the ground with anchor bolts.
- Because of the special relationship connecting rod and lever distances following movements of the scrapers obtain:
  - During the forward movement the scrapers moves practically parallel to the inclined bottom, then they lifted and turn back to the starting position.
- The moving parts are sufficiently protected so that they cannot be touched from the ground floor
- At the inlet, a construction fence is placed so that the turbulence in the setting chamber is limited;

## Paint work:

- Sandblasting SA3;
- Zinc epoxy primer: 40micron;
- Coal tar epoxy 2x150micron.

## Specifications:

- Length: 6m,8m,10m,12m;
- Width: 0,40m, 0,50m,0,60m,0,70m,0,80m;

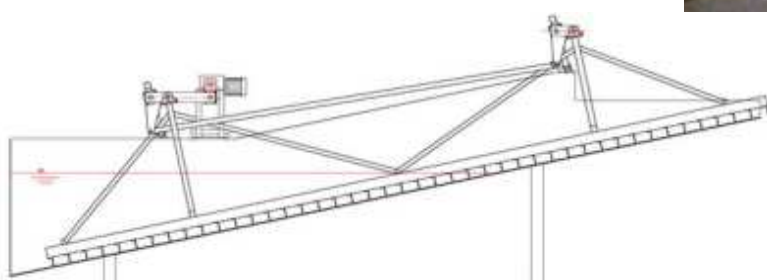

# RAKING BRIDGE RECTANGULAR

## Bridge frame:

- Hot rolled profiles with transverse and diagonal profiles;
- Hand railings:
  - Upper bar, height 1,10m above tread;
  - Intermediate bar at half height;
  - Plinth, height 150mm, according to ARAB.

## Wheel box:

- 4 guiding wheels each mounted on self-aligning ball bearings,
- dust- and waterproof;
- 4 side guide wheels to guide the bridge along the tank walls;
- All wheels are coated with the durable Vulkollan.



## Drive unit:

- 2 of the supporting wheels are driven.
- Motor-gearbox :
  - Hollow shaft motor;
  - Closed gearbox filled with oil;
  - Hermetic motor IP55;
  - Isolation class F;
  - Mounted on the outside of the bridge.

## Bottom scrapers:

- Triangles suspended on the bridge;
- Angled pulling profiles, attached to the bottom scrapers;
- Bottom scraper blades with adjustable height;
- Suspended by stainless steel cables to the cable drums.

## Surface scrapers:

- Suspended to the triangular profiles.

## Drive system scrapers:

- Hollow shaft gearbox motor, oil filled, motor IP55;
- Isolation class F;
- Fitted with electrical brake motor;
- Cable drums with grooved surface;
- All bearings can be greased from the surface of the bridge.



# RAKING BRIDGE RECTANGULAR

## Materials:

- Bridge: steel, with surface protection:
  - Sandblasting SA 2 ½;
  - Zinc spraying;
  - Epoxy painting 2 layers;
  - Surface finish: 2 component polyurethane paint;
  - Standard color: Emerald green, RAL6001
- All parts in contact with water: AISI 304



## Electrical equipment:

- All limit switches: type inductive proximity switches;
- Complete electrical control box with contactors, fuses, automatic switches, signal lamps;
- Complete wiring on the bridge;
- Electrical supply line.

# PONT RACLEUR CIRCULAIRE

## Bridge frame:

- steel frame with crossbeams as reinforcement;
- Hand railings:
  - Upper bar, height 1,10m above tread;
  - Intermediate bar at half height;
  - Plinth, height 150mm, according to ARAB;
  - Width: 1m between handrails.
- Easily accessible slipping collector;
- Galvanized gratins for an overload of 300kg/m<sup>2</sup>;

## Wheel box:

- Central bearing of large diameter;
- Lubrication possible from the walkways;
- 2 wheels whit 1 drive wheel;
- All wheels are coated with the durable Vulkollan.

## Drive unit:

- 1 of the supporting wheels are driven.
- Motor-gearbox :
  - Hollow shaft motor;
  - Closed gearbox filled with oil;
  - Hermetic motor IP55;
  - Isolation class F;
  - Mounted on the outside of the bridge.

## Bottom scraper:

- Rigid suspension structure;
- Bottom scraper blades with adjustable height.

## Surface scrapers:

- Mounted on the frame;
- Form: inclined to the center line of the bridge,
- for guiding of floating particle to the outside of the tank;
- Hinging part to guide the floating substances into a hopper.





# PONT RACLEUR CIRCULAIRE

## Materials:

- Bridge: steel, with surface protection
  - Sandblasting SA 2 ½;
  - Zinc spraying;
  - Epoxy paint 2 layers;
  - Standard color: Emerald green, RAL6001
- All parts in contact with water: AISI 304.

## Electrical equipment's:

- Obstacle detection;
- Wheel slip detection;
- Emergency stop;
- Complete cabling up to the slipping collector.



# FIXED CLEANING BRUSHES FOR GUTTERS

- A stainless steel frame is suspended to the moving bridge;
- Adjustable in height by means of stainless steel chain;
- Unit can be lifted for maintenance;
- The unit is custom-made designed;
- Pressure on side brushes is adjustable;
- Material of the brushes: nylon, high resistance to wear;
- Spare parts always in stock



# MOTORIZED CLEANING BRUSHES FOR GUTTERS

- A frame with a lifting mechanism;
- Position of the brush horizontally and vertically adjustable;
- Shape of the brush: adapted to the gutter;
- Drive unit: waterproof IP55;
- Unit can be lifted for maintenance and replacement;
- Can be combined with fixed brushes;
- Material of the brushes: nylon, highly abrasion resistant



# THICKENER MECHANISM

## General:

- With or without steel walkway;
  - Rake arms with thickening bars and bottom scrapers;
  - Diameter up to 20m;
  - Always equipped with durable lower bearing;
  - Materials in water/sludge: AISI304, AISI316 of coated steel;
  - A stirrer in the central sludge pit, bolted to the lower girder;
  - Two rake arms bolted to the central shaft;
  - Bottom scrapers bolted to the lower girder, positioned at 45°, to rake the sludge to the central pit;
- 
- The bottom surface of the tank is completely scraped in one rotation of the mechanism.

## Drive system:

- Gearbox fully closed, filled with oil;
- Hermetic motor IP 55;
- Isolation class F;
- External tooth wheel.

## Vertical driving tube-shaft, bolted to the central bearing, equipped with:

- A flange connection at the top;
- Extensions at the bottom and at  $\pm \frac{1}{3}$  height to fix the arms.



# CONVEYOR BELT

- The chassis consist of a sturdy welded construction;
- Customized support profiles for carrying the rollers;
- Two generously dimensioned end drums;
- The end drums are curved to ensure the alignment of the band;
- Bearings of the end drums on self-aligning ball bearings;
- The non-driving drum is mounted on the span sleds with 2 stainless steel wire rods;
- The rollers are made of stainless steel, coated steel or plastic;
- The rollers are equipped with waterproof bearings;
- The band is made of synthetic rubber, resistant to oil, fuel oil, etc.;
- The band has 2 strong layers, depending on the width of the band;
- Hermetic gear unit and motor with hollow-shaft drive group IP55;
- All moving parts are protected according to the European machine directives.

## Option:

- Full cover of the band with easily removable lids.



# SCREW CONVEYORS

- A stainless steel trough, thickness 3mm.
- In the trough is a wear-resistant layer of high strength. Thickness of the coating: 10mm.
- A screw in spiral form, thickness 20mm. The diameter is adapted to the trough.
- The screw rests over all its length on the coating.
- This coating is replaceable, in parts of 1,2,or 3m.
- The end of the screw is coupled by a support, bolted to the gearbox.
- The drive is a hollow shaft geared motor.
- The reducer is fixed to the trough by a support.
- The reducer is removable without disassembling the screw.
- The trough is covered by a bolted cover plate.
- The screw is equipped with inlet and outlet hoppers, and is entirely closed.
- The screw is made of special hard steel to resist to the maximum wear of friction.
- The supports are adapted to the local circumstances, and are included in the price, according to description in the offer.

Models			
Type	Trough width [mm]	Screw diameter [mm]	Approximate flow (volume) [m <sup>3</sup> /h]
U200	200	160	2,3
U260	260	215	4,2
U320	320	280	10
U420	420	380	23
U500	500	460	41
U600	600	560	75

POSITIONS: horizontal, inclined (all angles), vertical



# TWIN SCREWS

- A stainless steel trough, thickness 3mm.
- In the trough is a wear-resistant layer of high strength. Thickness of the coating: 10mm.
- Two screws in spiral form, thickness 20mm. The diameters are adapted to the trough.
- The screw rests over all its length on the coating.
- This coating is replaceable, in parts of 1,2,or 3m.
- The end of a screw is coupled by a support, bolted to the gearbox.
- The drive is a hollow shaft geared motor.
- The reducer is fixed to the trough by a support.
- The reducers are removable without disassembling the screws.
- The screw is made of special hard steel to resist to the maximum wear of friction.
- The supports are adapted to the local circumstances, and are included in the price, according to description in the offer.

Models			
Type	Trough width [mm]	Screw diameter [mm]	Approximate flow (volume) [m <sup>3</sup> /h]
U320	2x320=640	2x280	2x10=20
U420	2x420=840	2x380	2x23=46
U500	2x500=1000	2x460	2x41=82
U600	2x600=1200	2x560	2x75=150



# VALVE UNDER SCREW CONVEYOR

- A valve is specially designed to prevent the accumulate of sludge and fibers;
- While closing the valve makes an upward motion. This creates when opening a distance between the valve and the bottom of the screw trough;
- The special guiding profiles are performed blockage free.
- There are 2 options for the driving unit:
  - A pneumatic cylinder with built up electric valve;
  - A electrical driven threaded rod mechanism;
- The valve has 2 inductive limit switches.





# COMPACTOR

- A stainless steel trough, thickness 3mm.
- In the trough is a wear-resistant layer of high strength. Thickness of the coating: 10mm
- A screw in spiral form, thickness 20mm. The diameter is adapted to the trough.
- The screw rest over all its length on the coating.
- The coating is replaceable, in parts of 2 or 3m.
- The end of the screw is coupled by a support, bolted to the gearbox.
- The drive is done by a hollow shaft motor-reducer.
- The reducer is fixed to the trough by a bolted support.
- It is dismountable without disassembling the screw.
- The trough is covered by a bolted cover plate.
- The screw is equipped with inlet and outlet hoppers, and is entirely closed.
- The screw is made of special hard steel to resist to the maximum wear of friction.
- The supports are adapted to the local circumstances, and are included in the price, according to the description in the offer.
- At the end of the screw there is a perforated section.
- The product is compressed by means of a cover with adjustable counterweight.
- The squeezed water is discharged through a pipe 1 1/2".

Models			
Type	Sieve diameter [mm]	Screw diameter [mm]	Length [m]
U260	240	215	1...4
U320	300	280	4...6
INCLINATION: 10 à 30°			



# SEPARATOR

The installation is used for separating liquids from solid substances, in the sector of waste water.  
The installation is completely sealed and therefore this working scentless.

## Application

The unloading of trucks of sewer cleaning, cleaning of septic tanks, defibering of thickened sludge, etc...

## Principle

The mixture of liquids / solids is pumped through a sieve. In the sieve is a screw conveyor placed that transports the waste to the output. The waste is compacted by an adjustable pressure cover.

## Example

A truck of 12m<sup>3</sup> is emptied in 5 minutes.

## Option

- Longopack.
- Torque limiter

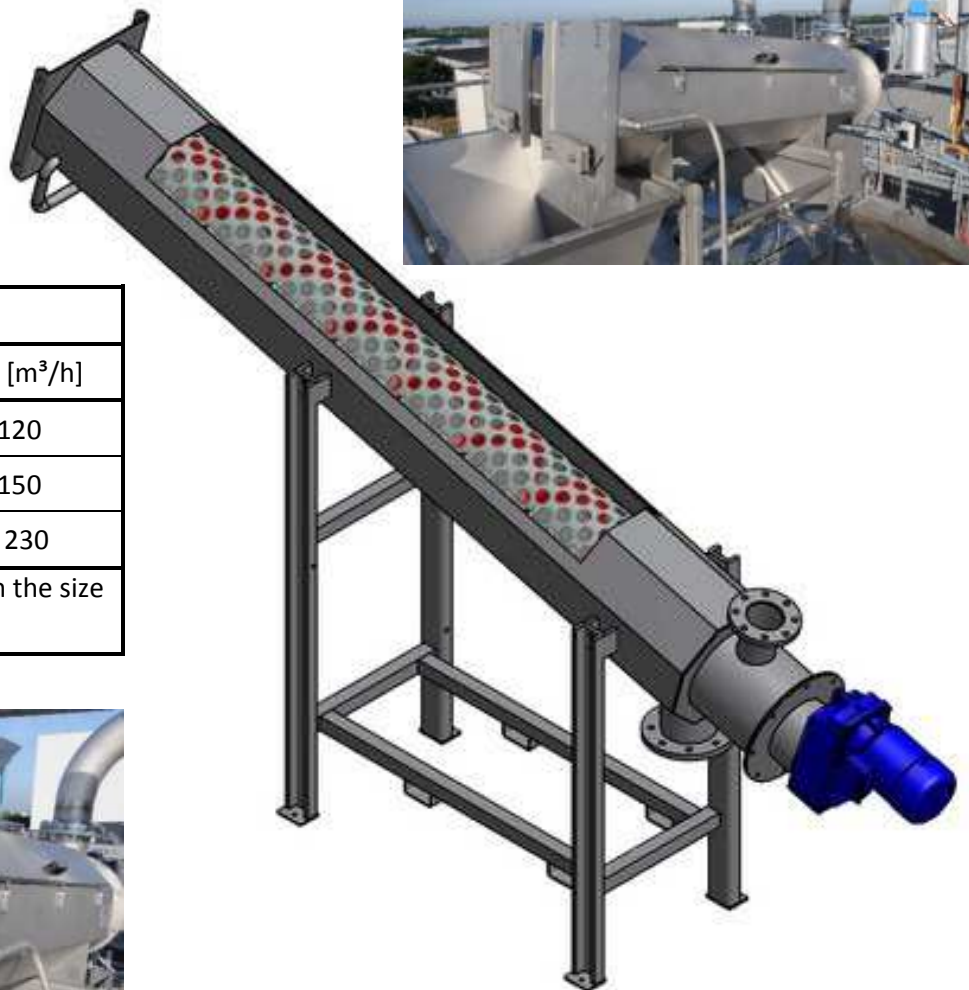

Models	
Type	Capacity [m <sup>3</sup> /h]
SEP 300	60 à 120
SEP 400	75 à 150
SEP 500	120 à 230
The capacity can vary depending on the size of the solids.	



# SCREW WITH MIXING ZONE

- A stainless steel trough, thickness 3mm.
- The trough is lined with hardox ingots or an HDPE layer with high strength.
- A screw in spiral form, thickness 20mm. The diameter is adapted to the trough.
- The screw rests over all its length on the coating.
- The end of the screw is coupled by a support, bolted to the gearbox.
- The drive is a hollow shaft geared motor.
- The reducer is fixed to the trough by a support.
- The reducer is removable without disassembling the screw.
- There is a sealing lantern with to protect the motor gearbox.
- The trough is covered by a bolted cover plate.
- The screw is equipped with inlet and outlet hoppers, and is entirely closed.
- The screw is made of special hard steel to resist to the maximum wear of friction.
- The screw is equipped with a mixing zone.
- The supports are adapted to the local circumstances, and are included in the price, according to description in the offer.

Models		
Type	Sieve diameter [mm]	Screw diameter [mm]
U320	320	280
U420	420	380
U500	500	460
U600	600	560

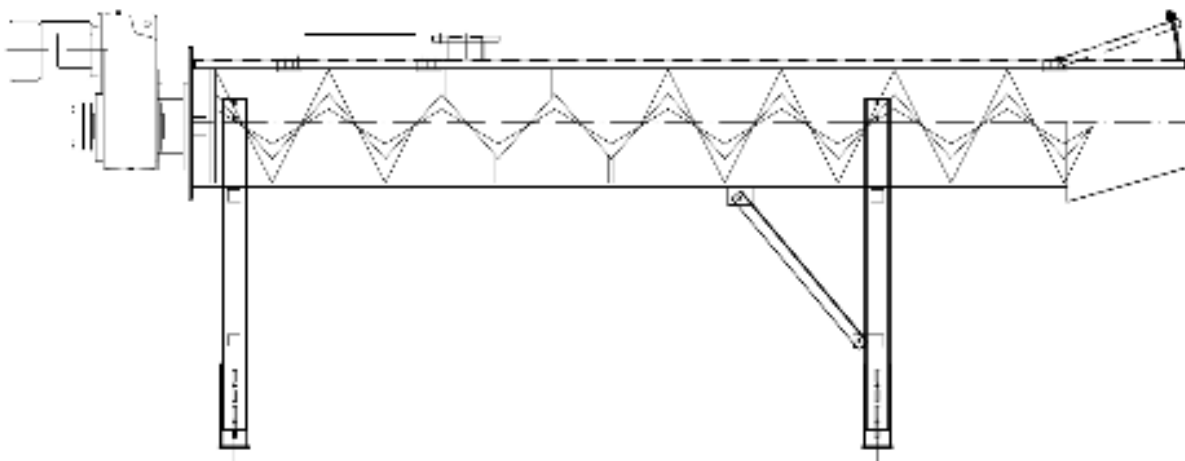

# RECEIVER UNIT

## Objective:

- Separation of liquid/solids;
- Unloading of trucks with waste from septic tanks, sewer cleaning, mixed sludges, ...
- capacity: 100 m<sup>3</sup>/h

## The unit consists of:

- A fine screen, type stepscreen.
  - Nominal width: 700mm;
  - Distance between bars: 6mm (optional: 3mm);
- A stone/sand screw:
  - The incoming material is separated in the first space; stones and coarse sand are removed.
- A compactor:
  - The waste is dewatered and compacted.

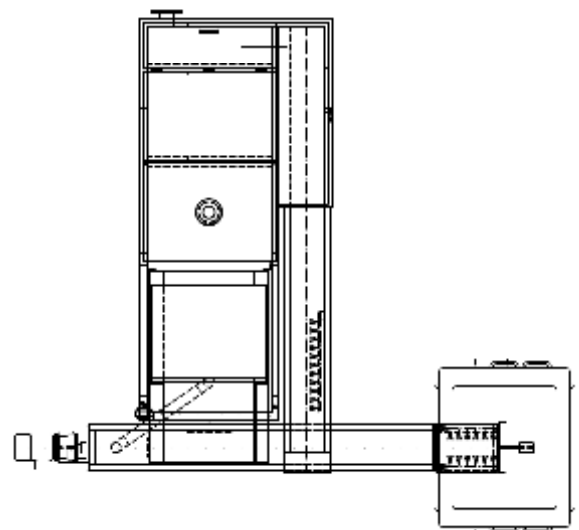
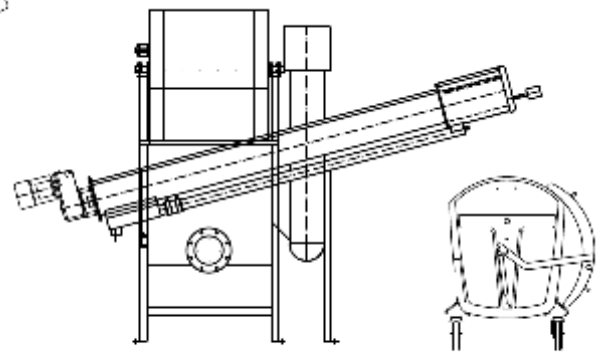
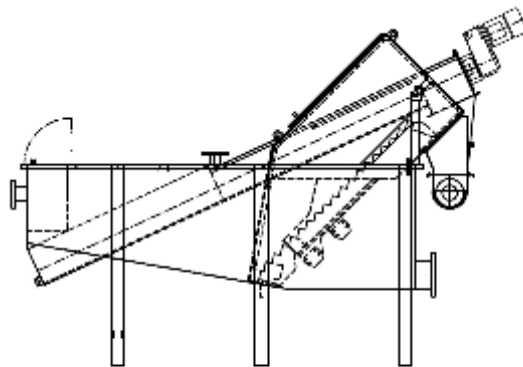

# LONGOPACK

- Hygienic disposal system for screenings;
- Sac in recyclable PE, length 90m;
- Easy replacement of sacs with colson strips;
- No direct contact between personnel and the product;
- No offensive smells or emission of heath damaging bacteria.



# HYDRAULIC COMPACTOR

The hydraulic compactor consists of:

- A frame mounted on supports;
- A hopper with horizontal rectangular flange;
- A high-pressure pipe which is perforated over a section to dewater and compact the product;
- The product is moved by a cylinder with hydraulic force. The pressure in the cylinder is adjustable;
- The cylinder moves on a wear-resistant plastic layer;
- The cylinder is driven by a hydraulic cylinder, mounted on maintenance-free bearing bushes;
- Volume reduction of the waste:  $\pm 1/2$ ;
- Content of dry matter:  $\pm 50\%$ ;
- A hydraulic unit;
- A hydraulic pump with filter;
- Pressure control valves;
- All fixed and flexible tubes;

OPTIONS: An electrical box for automatic and manual operation.



Models			
Type	Diameter [mm]	Stroke [mm]	Theoretical capacity [m <sup>3</sup> /h]
D250	250	800	9
D350	350	1000	17



# SLIVER SILO

## Silo with extraction screws:

- The cylindrical part of the silo is made up of welded steel plates.
- The roof consists of heavy tread plates with star shaped placed support plates; this is calculated for a overload of 300 kg/m<sup>2</sup>.
- In the middle of the roof there is an opening of 400x400mm with cover for the filling.
- There are 3 pipes with flange connections on the roof for the installation of measuring devices etc.: DN100, DN150 and DN200.
- A manhole in the side wall of the silo.
- The silo is equipped with 3, 4 or 5 shaft less screws, depending on the diameter of the silo. They are reinforced screws with a thickness of 25mm. The speed and the power are largely dimensioned to obtain the requested flow rate.
- Under the extraction screw there is a transverse screw placed to bring the product to one point.
- The silo is mounted on a heavy galvanized supporting structure.

## Options:

- Handrails on the circumference of the roof.
- Access ladder with back protection.
- Access ladder with platform to the manhole.
- Maintenance platform under the motors.

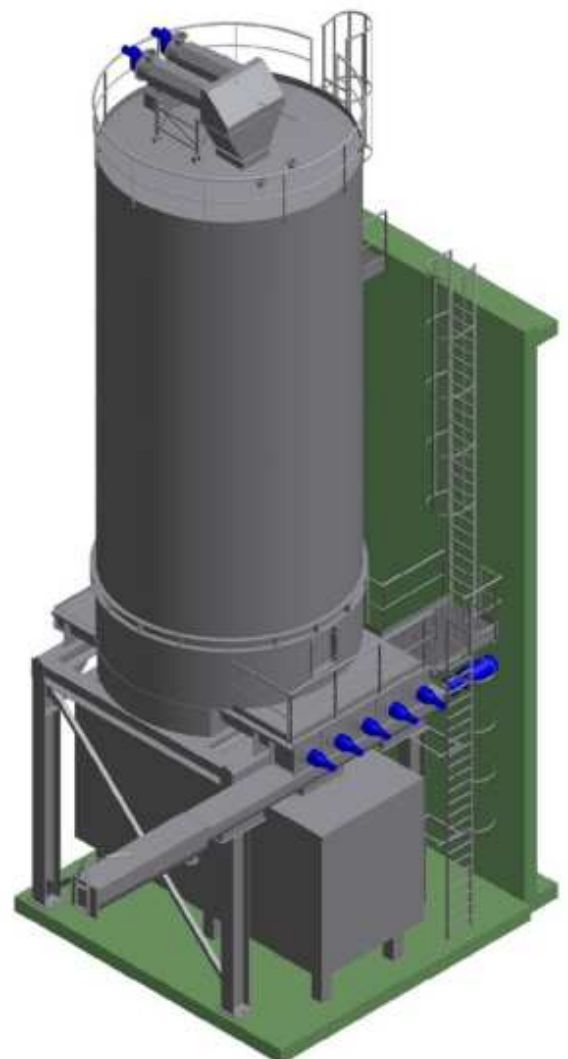

# SLUDGE SILO

- The tank part of the silo is made up of welded steel plates.
- In the middle of the roof there is an inspection opening.
- There are 3 pipes with flange connections on the roof for the installation of measuring devices etc.
- A manhole in the side wall of the silo.
- The silo is equipped with shaft less screws. They are reinforced screws with a thickness of 25mm. The speed and the power are largely dimensioned to obtain the requested flow rate.
- Under the extraction screw there is a screw conveyor to bring the product to one point.
- The silo is mounted on a heavy galvanized supporting structure.

## Options:

- Handrails on the roof.
- Access ladders
- Maintenance platform under the motors.





# CONTAINER WITH FILLING SCREW

- The container is made of a waterproof welded steel construction;
- 2 longitudinal beams IPN180, cross beams, side reinforcements;
- Extra reinforcements around the backdoor;
- Pickup system: diameter 50mm at standard height 1430mm;
- 2 rear wheels diameter 170mm with grease nipples;
- Backdoor performed as dustproof tilting door with 2 ratchet closures;
- Roof in sturdy bulb plate, accessible through a ladder with handles;
- Loading aperture: central back with dustproof cover;
- Shaft less screw diameter 280mm, with waterproof covers;
- Motor gearbox, IP55, easily accessible for maintenance;
- Level monitoring 100% FULL with inductive detector;
- CEE electrical connection type 32A (red);
- Harting multi pole connector;
- Coating exterior: cleaning, degreasing, zinc phosphate and 2 coats industry polish;
- Coating inside: 2 anti-rust layers.

Inside dimensions			
Length [m]	Width [m]	Height [m]	Volume [m <sup>3</sup> ]
5,00	2,20	0,83	<b>10</b>
5,50	2,20	1,65	<b>20</b>
6,00	2,30	2,20	<b>30</b>
7,00	2,38	2,10	<b>40</b>

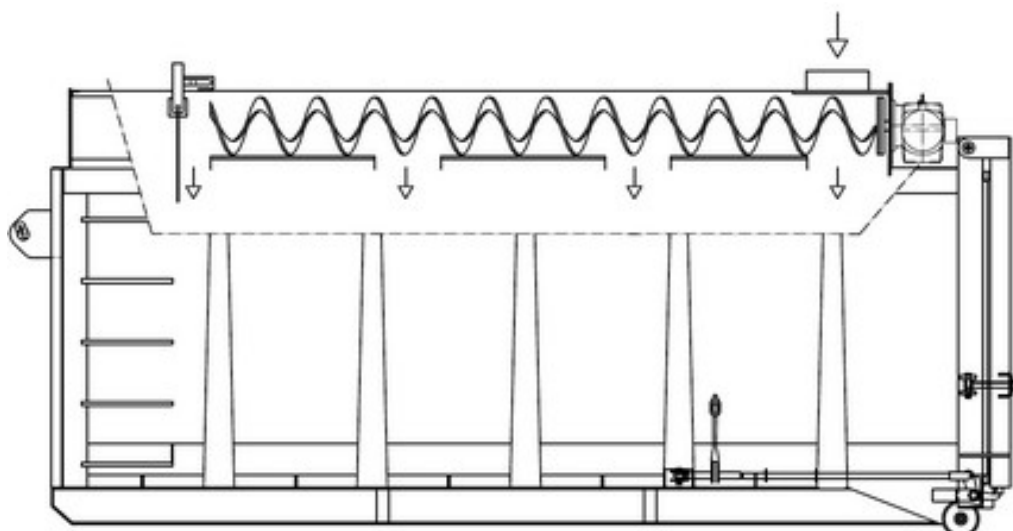

# ARCHIMEDEAN SCREW PUMPS

## Principle:

- A central pipe with spiral-shaped blades leads the water to a higher level.

## Feature:

- Robust open construction;
- Obstruction-free: suitable for water with solids;
- Automatic flow regulation;
- Low wear, so long service life;
- High efficiency;
- Extremely reliable;
- Installation angle: usually 30°...38°;
- Bearing lubrication: biodegradable grease;
- Can run dry without damage.



## Option:

- Prefabricated installation with steel trough.



Capacities (indicative)		
Diameter screw pump	30° [l/sec]	38° [l/sec]
500	45	35
750	120	90
1000	230	170
1250	380	290
1500	600	490
1800	900	690
2100	1300	980
2300	1600	1200

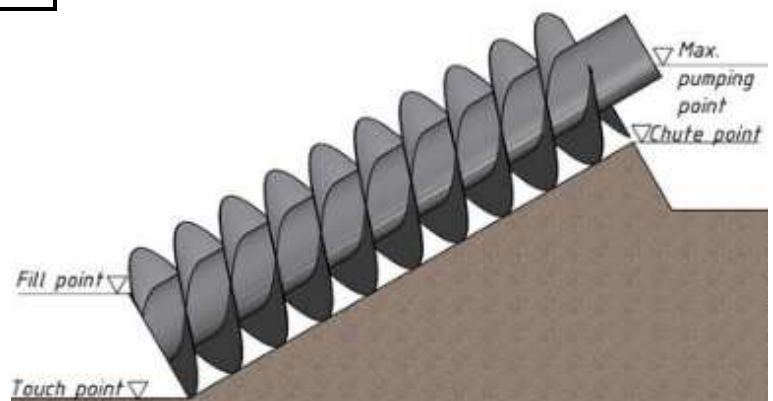

# CHAIN SCRAPER

- A frame consists of 2 main plates, reinforces to obtain a rigid unit;
- 2 guiding profiles are fixed to the frame;
- Two main rods are fixed on 2 self-aligning bearings;
- On each axle are 2 chain wheels fixed with ringcones;
- The motor-gearbox is the hollow shaft type. Service factor: 1,2.
- Two chains are fixed on the 4 chain wheels. The chains are of high resistant steel with special coating to withstand the corrosion of many acid greases;
- The scrapers are bolted to the chains;
- On both ends of every scraper there are high-resistant PE slots; they are easily replaceable;
- The unit is equipped with an electronic torque limiter.



# MIXING INSTALLATION

## Application:

Mixing of solid and liquid biomass with recirculated digestate.

The mixing must be gentle and slow so the heavy parts are allowed to sink and settle and to avoid that they are brought back upwards into the flow due to turbulence. Once settled the heavy parts should remain settled and the spiral on the paddles should gently sweep these parts into the screw.

## General:

- Vessel and mixers made of stainless steel;
- Slowly rotating central paddle;
- The vessel is foreseen with a level measurement, and an inspection opening;
- The paddle has paddle arms that force the solid biomass to be submerged into the digestate and liquid biomass and mix.
- The paddle also has a spiral that slowly moves the settling stones, gravel, sand, steel parts,... towards the screw.



## Drive system:

- Gearbox fully closed, filled with oil;
- Hermetic motor IP55;
- Isolation class F.

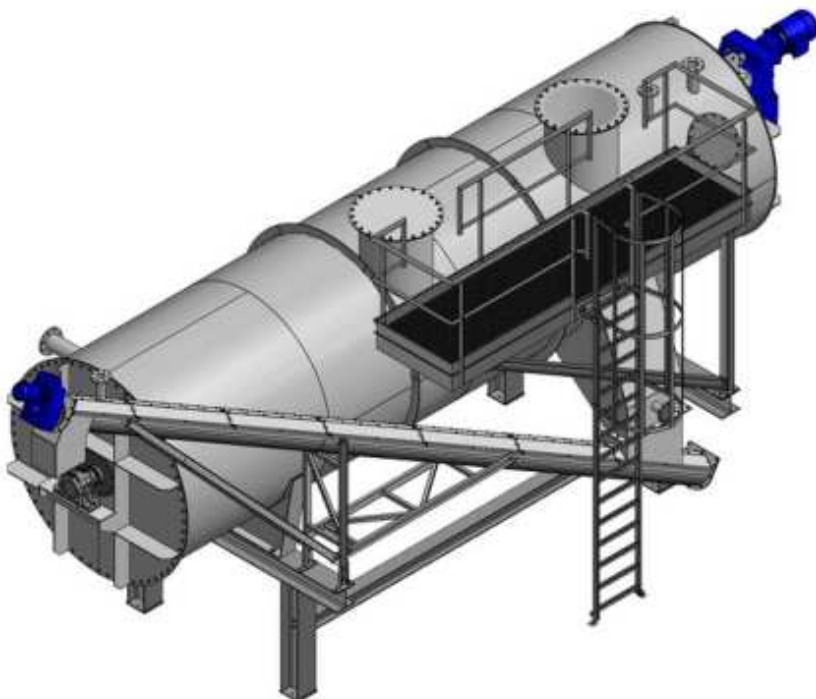



DEWEKON ENGINEERING  
ONDERNEMINGENSTRAAT 11  
8630 VEURNE  
INFO@DEWEKON.BE  
WWW.DEWEKON.BE

