



KROSNO

# GAS SPRINGS PRODUCT CATALOGUE

PRODUKTKATALOG  
FÜR GASFEDERANWENDUNGEN

KATALOG ZASTOSOWAŃ  
SPRĘŻYN GAZOWYCH



## TABLE OF CONTENTS

I	<b>Introduction</b>	4
	About Krosno	5
	FA Krosno	6
	The demands we put on ourselves	9
II	<b>Basic information about gas springs</b>	10
	Gas spring design	11
	Gas spring with hydraulic damping	12
	Gas spring with dynamic damping	15
	Selection of gas springs	16
	Safety and handling	16
	Transport and storage	19
III	<b>FA-RISE gas springs</b>	21
	Diameter 6/15	22
	Diameter 8/19	24
	Mountings for 6/15 and 8/19	27
	Diameter 10/22	29
	Mountings for 10/22	32
	Diameter 14/28	34
	Mountings for 14/28	36
	Diameter 20/40	38
	Mountings for 20/40	39
	FA-HOLD gas springs	40
	FA-2STAGE gas springs	41
	Special and customized gas springs	42
IV	<b>FA-BLOCK gas springs</b>	45
	Diameter 10/22	46
	Diameter 10/28	47
V	<b>FA-TRAC gas springs (traction gas springs)</b>	49
VI	<b>FA-INOX gas springs + mountings</b>	53
VII	<b>FA-ABS Dampers and oil brakes</b>	57
VIII	<b>Accessories</b>	61

## INHALTSVERZEICHNIS

I	<b>Einleitung</b>	4
	Die Stadt Krosno	5
	Das Unternehmen FA Krosno	6
	Unsere Anforderungen an uns selbst	9
II	<b>Grundlegende Informationen über Gasfedern</b>	10
	Konstruktion der Gasfeder	11
	Gasdruckfeder mit hydraulischer Dämpfung	12
	Gasdruckfeder mit dynamischer Dämpfung	13
	Auswahl von Gasfedern	14
	Sicherheit und Handhabung	16
	Transport und Lagerung	19
III	<b>FA-RISE Gasdruckfedern</b>	21
	Durchmesser 6/15	22
	Durchmesser 8/19	24
	Anschlüsse für 6/15 und 8/19	27
	Durchmesser 10/22	29
	Anschlüsse für 10/22	32
	Durchmesser 14/28	34
	Anschlüsse für 14/28	36
	Durchmesser 20/40	38
	Anschlüsse für 20/40	39
	FA-HOLD Gasdruckfedern	40
	FA-2STAGE Gasdruckfedern	41
	Spezial- und kundenspezifische Gasfedern	42
IV	<b>FA-BLOCK Blockierbare Gasfedern</b>	45
	Durchmesser 10/22	46
	Durchmesser 10/28	47
V	<b>FA-TRAC Zuggasfedern</b>	49
VI	<b>FA-INOX Edelstahlgasfedern + Anschlüsse</b>	53
VII	<b>FA-ABS Dämpfer und Ölbrem sen</b>	57
VIII	<b>Zubehör</b>	61

## SPIS TREŚCI

I	<b>Wstęp</b>	4
	O Krośnie	5
	FA Krosno	6
	Wymagania wobec nas samych	9
II	<b>Podstawowe informacje o sprężynach gazowych</b>	10
	Budowa sprężyny gazowej	11
	Sprężyna gazowa z tłumieniem hydraulicznym	12
	Sprężyna gazowa z tłumieniem dynamicznym	13
	Dobór sprężyn gazowych	14
	Bezpieczeństwo i obsługa	16
	Transport i przechowywanie	19
III	<b>Sprężyny pchające FA-RISE</b>	21
	Typ 6/15	22
	Typ 8/19	24
	Mocowania dla 6/15 i 8/19	27
	Typ 10/22	29
	Mocowania dla 10/22	32
	Typ 14/28	34
	Mocowania dla 14/28	36
	Typ 20/40	38
	Mocowania dla 20/40	39
	Sprężyny gazowe FA-HOLD	40
	Sprężyny gazowe FA-2STAGE	41
	Sprężyny specjalne i dostosowane do szczególnych wymagań klienta	42
IV	<b>Sprężyny blokowane FA-BLOCK</b>	45
	Typ 10/22	46
	Typ 10/28	47
V	<b>Ciągące sprężyny gazowe FA-TRAC</b>	49
VI	<b>Sprężyny ze stali nierdzewnej FA-INOX + mocowania</b>	53
VII	<b>Tłumiki i hamulce olejowe FA-ABS</b>	57
VIII	<b>Aksesoria</b>	61

I.

# INTRODUCTION

# ABOUT KROSNO

Krosno - located 180 km east of Krakow - is one of the most attractive towns in south-eastern Poland. This picturesque place is a cradle of various industries. It is here that the first crude oil mining was started and the famous glassworks were created at the beginning of the 19<sup>th</sup> century. Nowadays Krosno is the largest national centre of glass manufacturing and an important center of automotive, aviation and furniture production.

Krosno is also a strong industrial and service center, highly rated in rankings as a business-friendly and attractive investment location. More than 5,000 business entities operate here, of which 97% are private companies.

## DIE STADT KROSNO

Krosno - 180 km östlich von Krakau gelegen - ist eine der schönsten Städte im Südosten Polens und gleichzeitig die Wiege vieler Industriezweige.

Hier entstand Anfang des 19. Jahrhunderts die bekannteste Glashütte der Welt. Heute ist diese Stadt das größte nationale Zentrum der Glasindustrie und ein bedeutender Standort der Automobil-, Luftfahrt- und Möbelindustrie.

Krosno ist ein ausgeprägtes Industrie- und Dienstleistungszentrum, das als besonders wirtschafts- und investitionsfreundlich gilt. Hier zählt man mehr als 5000 Unternehmen in der Stadt, von denen 97% in privater Hand sind.

## O KROŚNIE

Krosno - położone 180 km na wschód od Krakowa - to jedno z najpiękniejszych miast w południowo-wschodniej Polsce, a jednocześnie kolebka wielu przemysłów. To właśnie tutaj narodził się światowy przemysł naftowy, a na początku XIX wieku powstały najstynniejsze na świecie huty szkła. Dzisiaj w Krośnie znajduje się największy krajowy ośrodek przemysłu szklarskiego oraz ważne ośrodki przemysłu motoryzacyjnego, lotniczego oraz meblarskiego.

Krosno jest również silnym ośrodkiem przemysłowym i usługowym, wysoko ocenianym w rankingach jako miasto przyjazne dla biznesu i atrakcyjne inwestycyjnie. Działa tutaj ponad 5 tysięcy podmiotów gospodarczych, a 97% z nich to firmy prywatne.



FA KROSNO GMBH  
GERMANY

FA KROSNO S.A.  
POLAND

ENG

# FA KROSNO

**FA KROSNO IS A MANUFACTURER WITH YEARS OF EXPERIENCE IN PRODUCTION OF GAS SPRINGS. STARTING IN THE MID-1970'S, AFTER ESTABLISHING A PRODUCTION FACILITY IN KROSNO OUR COMPANY SUPPLIED ITS FIRST AUTOMOTIVE CUSTOMERS.**

Modern production methods and continuous investment in automated production lines allow **FA Krosno** to meet the expectations of the most demanding customers in the automotive market. Currently, the company provides products for many leading OE manufacturers and supplies many well-known distributors. In parallel with the development of springs for the automotive industry, **FA Krosno** develops industrial gas springs for businesses such as construction, furniture, agriculture, boatbuilding and medical equipment.

**FA Krosno** is a company in which an exceptional team of people build their careers by designing and creating new products which are sought-after in the market. Our qualified team sets new standards of reliability and quality that are appreciated in the automotive and many other industries. The requirements and wishes of our customers are incorporated already in the design phase. This way, cooperating with our customers, we create perfect solutions for applications which employ our gas springs. Together with our international sales and engineering structure in Poland and Germany, we are always close to our customers.

We win over our customers with quality and efficiency. Our products offer an outstanding price-quality ratio. Thanks to the convenient location in Central Europe and extensive logistics network, we provide fast and timely deliveries.





D|

## DAS UNTERNEHMEN FA KROSNO

Der Firma FA Krosno ist ein Unternehmen mit langjähriger Erfahrung in der Herstellung von Gasfedern. Bereits seit Mitte der 70er Jahre, nach der Eröffnung der Produktionsstätte in Krosno, belieferte unser Unternehmen seine ersten Kunden aus der Automobilindustrie.

Moderne Produktionsmethoden und kontinuierliche Investitionen in vollautomatische Produktionslinien ermöglichen es der FA Krosno, die Erwartungen auch der anspruchsvollsten Kunden auf dem Automobilmarkt zu erfüllen. Derzeit beliefert das Unternehmen viele führende OE-Hersteller und namhafte Handelsunternehmen. Parallel zur Entwicklung von Gasfedern für die Automobilindustrie entwickelt FA Krosno industrielle Gasfedern für viele Branchen wie beispielsweise: Baumaschinen, Möbel, Landwirtschaft, Bootsbau, Medizintechnik und Forsttechnik.

FA Krosno ist das Unternehmen, in dem ein außergewöhnliches Team von Menschen, die sich täglich neuen Herausforderungen stellen und neue Produkte entwickeln, um auf dem Markt besondere Akzente zu setzen. Dabei erreichen unsere Mitarbeiter neue Maßstäbe in Sachen Zuverlässigkeit und Qualität, die in der Automobilindustrie und vielen anderen Branchen geschätzt werden. Die Anforderungen und Wünsche unserer Kunden werden bereits in der Konstruktionsphase berücksichtigt. Somit schaffen wir gemeinsam perfekte Lösungen für die Anwendungen unserer Gasfedern. Gemeinsam mit unserer internationalen Vertriebs- und Ingenieurstruktur in Polen und Deutschland sind wir stets nahe bei unseren Kunden.

Wir überzeugen unsere Kunden mit Qualität und Effizienz. Dabei bieten unsere Produkte ein hervorragendes Preis-Leistungs-Verhältnis. Durch die verkehrsgünstige Lage in Mitteleuropa und ein weit verzweigtes Logistiknetz sorgen wir für schnelle und pünktliche Lieferungen zu unseren Kunden.

P|

## FA KROSNO

FA Krosno ma 40-letnie doświadczenie w produkcji sprężyn gazowych. Już od połowy lat 70 - tych nasza firma zaopatrywała klientów w sprężyny gazowe. W 2006 roku firma przeszła zmiany właścicielskie i stała się prywatną firmą z polskim kapitałem.

Nowoczesna technologia produkcji i ciągłe inwestycje w zautomatyzowane linie produkcyjne pozwalają FA Krosno sprostać oczekiwaniom najbardziej wymagających klientów rynku motoryzacyjnego. Obecnie firma dostarcza wyroby dla wielu wiodących producentów OE i zaopatruje najbardziej znanych dystrybutorów na rynku wtórnym. Równoległe do rozwoju sprężyn dla motoryzacji rozwijamy w FA Krosno produkcję sprężyn przemysłowych dla budownictwa, meblarstwa, rolnictwa, jachtingu, do urządzeń medycznych i leśnych.

FA Krosno to firma, w której wyjątkowy zespół ludzi buduje swoją karierę projektując oraz tworząc nowe, poszukiwane na rynku produkty. Wspólnie z naszym wykwalifikowanym zespołem wyznaczamy nowe standardy niezawodności i jakości, które są doceniane zarówno w branży motoryzacyjnej jak i w wielu innych. Wymagania i życzenia naszych klientów są uwzględniane już w fazie projektowania. W ten sposób, we współpracy z naszymi klientami powstają idealne rozwiązania dla urządzeń z zastosowaniem naszych sprężyn gazowych. Dzięki współpracy naszego biura sprzedaży i ośrodków konstrukcyjnych w Polsce i Niemczech jesteśmy zawsze blisko naszych klientów.

Przekonujemy klientów jakością i wydajnością. Nasze wyroby mają doskonały współczynnik jakości do ceny. Dzięki dogodnej lokalizacji w środkowej Europie i wysoko rozwiniętej logistyce zapewniamy szybkie i terminowe dostawy.



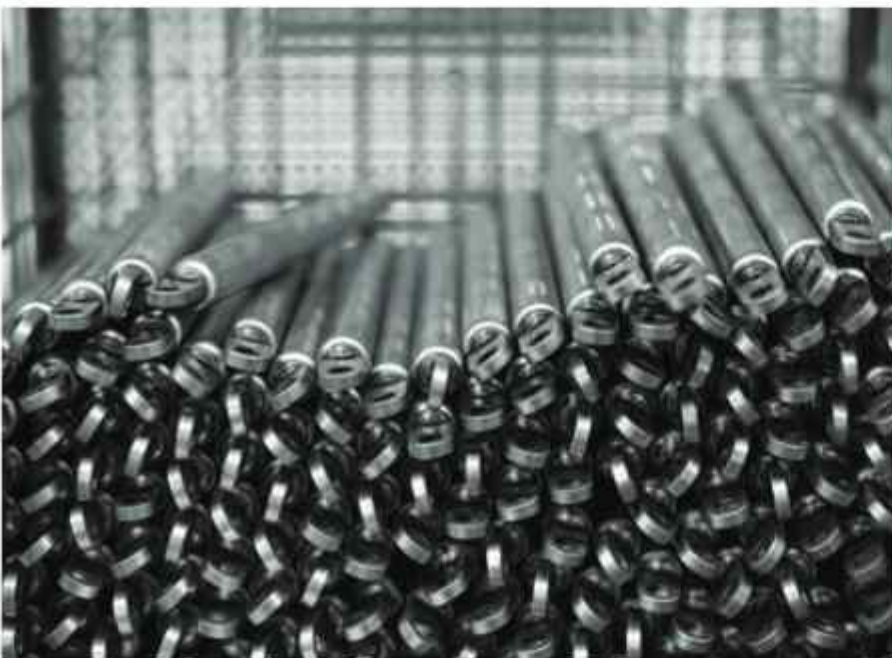



# THE DEMANDS WE PUT ON OURSELVES



Millions of gas springs from FA Krosno are used each day in countless applications, reliably and maintenance-free. Quality and reliability of our products and competent advice delivered at competitive cost are our utmost priority. Our commitment to the highest quality standards is confirmed by ISO 9001 and TS 16949 certification.

Our commitment to those standards and principles are reasons why so many large industrial and automotive customers entrusted us for many years with their gas spring needs. Our customers, employees and suppliers are given individualized approach based on trust and mutual benefit. We share responsibility for our environment. We are committed to responsible use of common resources which is confirmed by ISO 14001 certification.

I)

## UNSERE ANFORDERUNGEN AN UNS SELBST

Millionen von Gasfedern von FA Krosno werden täglich in den unterschiedlichsten Anwendungen zuverlässig und wartungsfrei eingesetzt. Qualität und Zuverlässigkeit unserer Produkte sowie kompetente Beratung zu wettbewerbsfähigen Kosten sind unsere oberste Priorität. Dies wird durch regelmäßige Zertifizierungen nach ISO 9001 und TS 16949 bestätigt.

Die Anforderungen und Wünsche unserer Kunden werden bereits in der Entwicklungs- und Konstruktionsphase so berücksichtigt, dass die jeweils optimale Gasfederlösung für die Anwendung entsteht. Dies ist einer der Gründe, warum uns so viele Kunden in der Industrie und Automobilbranche seit Jahren vertrauen. Der persönliche, vertrauensvolle und faire Umgang mit unseren Kunden, Mitarbeitern und Lieferanten ist dabei fest in unseren Werten verankert. Wir tragen Verantwortung für unsere gemeinsame Umwelt. Dafür haben wir die bei uns eingesetzten ressourcenschonenden Produktionsstandards unabhängig bewerten und nach der Umweltmanagementnorm ISO 14001 zertifizieren lassen.

II)

## WYMAGANIA WOBEC NAS SAMYCH

Codziennie miliony sprężyn gazowych z FA Krosno jest wykorzystywanych w wielu dziedzinach niezawodnie i bezobsługowo. Jakość i niezawodność naszych produktów dostarczanych w konkurencyjnych cenach są naszym najwyższym priorytetem. Fachowe doradztwo jest u nas zawsze na pierwszym miejscu. Potwierdzają to regularnie odnawiane certyfikaty zgodnie ze standardami ISO 9001 jak również TS 16949.

To jeden z powodów, dla których tak wielu klientów w przemyśle, jak również wielu klienci branży motoryzacyjnej ufają nam od lat. Indywidualne podejście, uczciwe i oparte na wzajemnym zaufaniu traktowanie naszych klientów, pracowników i dostawców są mocno zakorzenione w naszych wartościach. Ponosimy odpowiedzialność za środowisko naturalne. Nasze standardy produkcji pozwalają oszczędzać zasoby, są niezależnie oceniane i certyfikowane wg norm ISO 14001.

11.

# BASIC INFORMATION ABOUT GAS SPRINGS

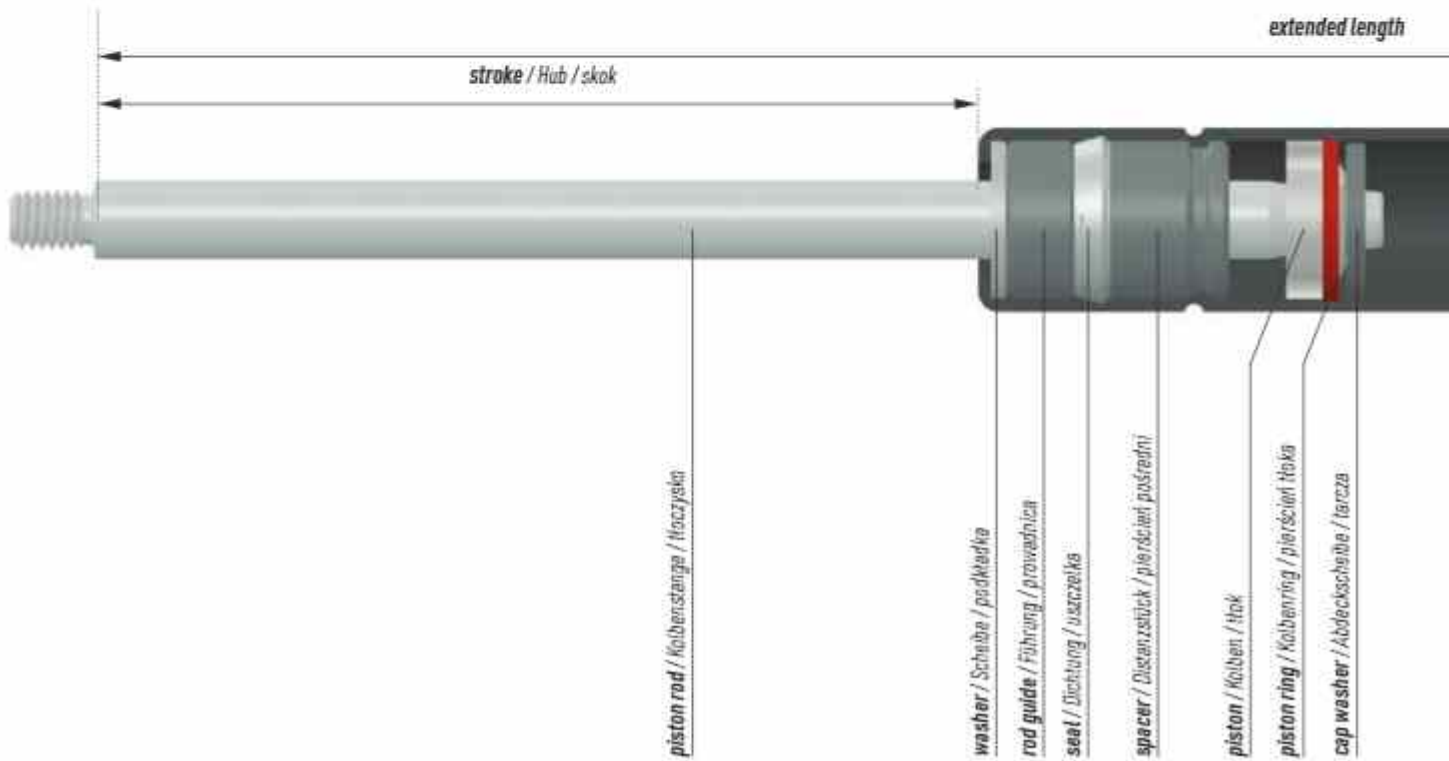

*/ ausgeschobene Länge / w stanie rozciągniętym*



*oil + nitrogen / Öl + Stickstoff / olej + azot*

*cylinder / Zylinder / cylinder*



# GAS SPRING WITH HYDRAULIC DAMPING

The gas flow is done through the piston in the pneumatic (gas) area of the stroke. When reaching the hydraulic (oil) area the speed is damped due to the higher viscosity of the medium. This function is dependent on the orientation of the gas spring.

Recommended installation mode for hydraulic damping of gas springs is presented in section „Safety and handling”

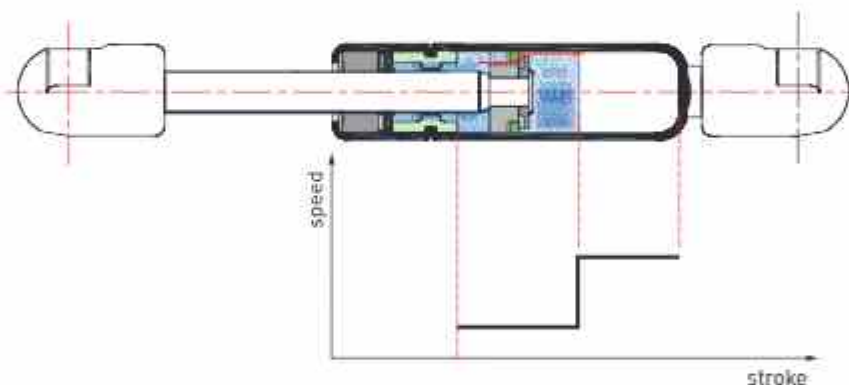

## GASDRUCKFEDER MIT HYDRAULISCHER DÄMPFUNG

Der Gasfluss findet über den Kolben innerhalb des pneumatischen (Gas-) Bereichs im Hub statt. Beim Erreichen des hydraulischen (Öl-) Bereichs wird die Geschwindigkeit durch die höhere Viskosität des Mediums gedämpft.

Diese Funktion ist abhängig von der Einbaulage der Gasdruckfeder.

## SPRĘŻYNA GAZOWA Z TŁUMIENIEM HYDRAULICZNYM

Przepływ gazu odbywa się przez tłok w obszarze pneumatycznym (gazowym) skoku. Po osiągnięciu obszaru hydraulicznego (olejowego) prędkość jest tłumiona z powodu wyższej lepkości medium. Efektywność funkcji zależy od kierunku montażu sprężyny gazowej.

# GAS SPRING WITH DYNAMIC DAMPING

The gas flow inside a gas spring takes place via the longitudinal groove in the cylinder. Reduced cross section of the groove on one side is used to dampen speed of a piston rod. This gas spring solution offers an optimized and completely position-independent extension speed as well as end position damping of the gas spring.

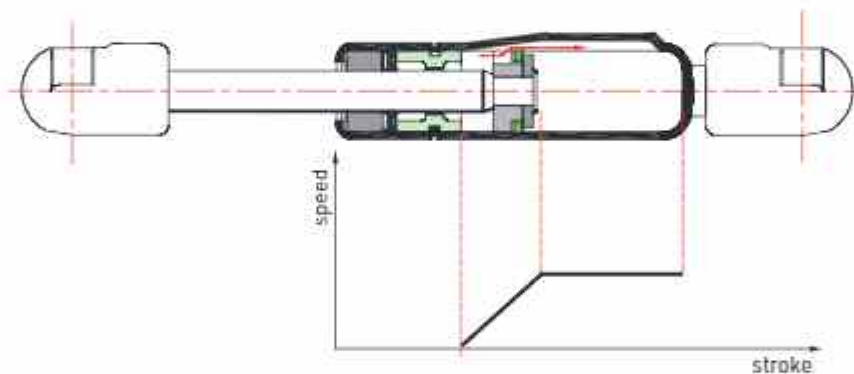

DE

## GASDRUCKFEDER MIT DYNAMISCHER DÄMPFUNG

Der innere Gasfluss findet über die langslaufende Nut im Zylinder statt. Dabei wird zum einen ein konstanter sowie ein abnehmender Querschnitt zur Enddämpfung verwendet. Diese Gasfederlösung bietet eine optimierte und komplett lageunabhängige Ausschubgeschwindigkeit wie auch Endlagendämpfung der Gasdruckfeder.

PL

## SPRĘŻYNA GAZOWA Z TŁUMIENIEM DYNAMICZNYM

Wewnętrzny przepływ gazu odbywa się poprzez podłużny rowek w cylindrze. Z jednej strony do końcowego tłumienia stosuje się stały, a następnie malejący przekrój poprzeczny. Takie rozwiązanie sprężyny gazowej zapewnia zoptymalizowaną i całkowicie niezależną od położenia prędkość wysuwania, jak również amortyzację położenia końcowego sprężyny gazowej.

# APPROXIMATE CALCULATION FOR INSTALLATION PROPOSAL

ÜBERSCHLAGSBERECHNUNG FÜR DIE GASFEDERAUSLEGUNG  
KALKULACJA SZYBKIEGO DOBORU SPRĘŻYN GAZOWYCH

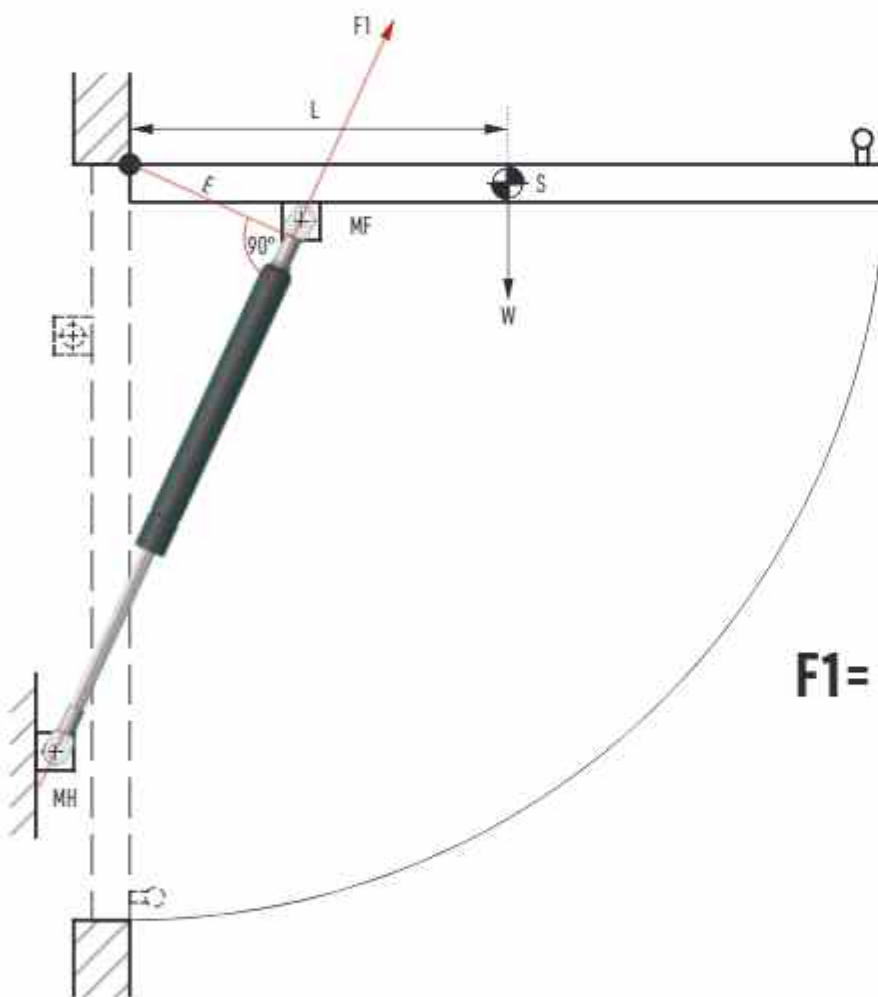

$$F1 = \frac{W \times L \times 9,81}{E \times n} \times 1,2$$

ENG

F1	extension force F1 [N]
W	weight of flap [kg]
L	Length from pivot point to gravity point [cm]
E	effective leverage arm [cm]
S	gravity point of flap
n	number of gas springs
MF	Mounting point on flap
MH	mounting point on holder (frame)
9,81	conversion factor kg to N
1,2	20% needed force surplus

DE

F1	Ausschubkraft [N]
W	Klappengewicht [kg]
L	Länge vom Drehpunkt zum Schwerpunkt [cm]
E	wirksamer Hebelarm [cm]
S	Klappenschwerpunkt
n	Anzahl der Gasdruckfedern
MF	Befestigungspunkt an der Klappe
MH	Befestigungspunkt am Rahmen
9,81	Umrechnungsfaktor kg nach N
1,2	20% nötiger Kraftüberschuss

PL

F1	siła F1 [N]
W	waga [kg]
L	odległość od osi obrotu do punktu ciężkości
E	efektywne ramię dźwigni [cm]
S	punkt ciężkości kłapy
n	ilość sprężyn gazowych
MF	punkt mocowania na klapie
MH	punkt mocowania na ramie
9,81	przelicznik zamiany z kg na N
1,2	20% dodatek siły



## HOW TO FIND THE PROPER PARAMETERS OF A GAS SPRING

Please specify:

- weight of the flap **W** in kilograms
- approximate - length to the center of gravity of the flap **L**  
(distance from the axis of the hinge to the center of the flap in the open state)
- distance **E** between the point of fixing the gas spring to the flap and the axis of its rotation
- quantity of gas springs **n** (usually 2pcs)
- approximate calculation for needed F1 force:  $F1 = ((W * L * 9,81) / (E * n)) * 1,2$
- having the required stroke (difference in the distance between the spring fixing points in the opened and closed state of the flap) and F1 force the appropriate spring from the catalogue can be chosen.

DE

### SO FINDEN SIE DIE RICHTIGEN WERTE FÜR DIE GASFEDER

Zu ermitteln:

- Gewicht der Klappe **W** in Kilogramm
- annähernd den Schwerpunkt der Klappe **L** (Abstand des Scharnierdrehpunkts zur Mitte der Klappe im geöffneten Zustand)
- den Abstand **E** zwischen dem Scharnierdrehpunkt und dem Befestigungspunkt der Gasfeder an der Klappe
- Anzahl der Gasdruckfedern **n** (in der Regel 2 Stück)
- Mit den ermittelten Daten kann die notwendige Ausschubkraft F1 berechnet werden:  $F1 = ((W * L * 9,81) / (E * n)) * 1,2$
- nach Ermittlung des erforderlichen Hubs (Unterschied zwischen den Abstand der Befestigungspunkte AK bei geöffneter und geschlossener Klappe) und der Kraft F1 kann die geeignete Gasfeder aus dem Katalog ausgewählt werden.

PL

### SPRĘŻYNY GAZOWE - DOBÓR SPRĘŻYNY

Aby dobrać sprężynę gazową należy określić:

- ciężar klapy **W** w kilogramach
- w przybliżeniu środek ciężkości klapy **L** (odległość od osi zawiasów do środka klapy w stanie otwartym)
- odległość **E** między punktem mocowania sprężyny gazowej do klapy a osią obrotu klapy,
- ilość sprężyn gazowych **n** (zwykle 2)
- obliczamy siłę sprężyny:  $F1 = ((W * L * 9,81) / (E * n)) * 1,2$
- mając wymagany skok (różnica odległości między punktami mocowania sprężyny w stanie otwartym i zamkniętym klapy) i siłę F1 dobieramy odpowiednią sprężynę z katalogu.

# SAFETY AND HANDLING

**HIGH QUALITY GAS SPRINGS FROM FA KROSNO PROVIDE COMFORT AND SAFETY IN COUNTLESS APPLICATIONS IN OUR DAILY LIFE. THEY ARE DESIGNED TO REDUCE HUMAN EFFORT TO OPEN FLAPS AND LIFT HATCHES WHILST MAKING COVER MOVEMENTS SMOOTH AND CONTROLLED.**

Quality components and robust design make our gas springs a reliable companion for many years. Our gas springs are fully tested before they leave the factory to ensure that all customer specifications are met. This is yet another step that guarantees the perfect quality of our products. When designing applications that incorporate gas springs, please observe essential principles which are the basis for safe and long-lasting use.

- For utilization and recycling of gas springs - the legal requirements must be observed.
- Never attempt to open a gas spring or change the design. Gas springs are filled with nitrogen, which is safe in itself but, because it can be compressed up to 200 bars in the spring, any action leading to release of pressure can cause death, serious personal injury or property damage. The same applies to improper selection and use of the products described herein or related items.
- Standard gas springs are designed for use in the temperature range from -30°C to +80°C. For other temperature ranges we offer special gas springs.
- Our products are designed to withstand tens of thousands of cycles in standard conditions. The service life of a gas spring depends on many external factors such as temperature, humidity and environmental conditions.
- Our gas springs are maintenance-free. Do not oil or grease a piston rod.
- Gas springs cannot be subjected to transverse forces, tensile forces especially over maximum extension, vibrations, oscillations or high temperatures.
- Gas springs cannot function as an end stop. To limit the maximum opening the appropriate end stop must be used.
- The proper functioning of gas springs is primarily ensured by proper sealing and piston rod surface, which together guarantee that gas pressure inside the cylinder is maintained. Any mechanical damage of a piston rod surface can lead to loss of functionality. Therefore protect the piston rod against knocks, dirt, scratches and paint.
- Installation of gas springs which have visible damage and / or are incomplete is not permitted.
- Gas springs cannot be subject to any modifications (e.g. shortening, lengthening, welding), interferences with the spring construction, heating, grinding, opening or drilling, removal of prints, replacement of fasteners, etc.
- The gas spring should be assembled and disassembled in a stretched condition according to the sketches presented. It is not permissible to dismantle the compressed or partially compressed spring.



## SICHERHEIT UND HANDHABUNG

Qualitäts-Gasfedern von FA Krosno bieten Komfort und Sicherheit in unzähligen Anwendungen unseres täglichen Lebens. Sie wurden entwickelt, um den Aufwand beim Öffnen von Klappen und anderen Anwendungen zu reduzieren und gleichzeitig die Bewegungen sanft und kontrolliert zu gestalten. Hochwertige Komponenten und robuste Konstruktion machen unsere Gasfedern zu einem zuverlässigen Begleiter für viele Jahre.

Unsere Gasfedern werden vor dem Verlassen des Werkes umfassend getestet, um sicherzustellen, dass alle Kundenspezifikationen erfüllt werden. Dies ist ein weiterer Schritt, der die einwandfreie Qualität unserer Produkte garantiert.

Bei der Auslegung von Anwendungen mit Gasfedern sind die wesentlichen Grundsätze zu beachten, die die Grundlage für einen sicheren und langlebigen Einsatz sind.

- Versuchen Sie niemals, eine Gasfeder zu öffnen. Gasfedern sind mit Stickstoff gefüllt, der an sich unbedenklich ist, aber da er in der Gasfeder mit einem Druck von bis zu 200 bar komprimiert wird, kann jeder Missbrauch der zur explosionsartigen Entladung führt, Tod, schwere Körperverletzung und Sachschäden verursachen.
- Standard-Gasfedern sind für den Temperatureinsatzbereich von -30°C bis +80°C ausgelegt. Für andere Temperaturbereiche bieten wir spezielle Gasfedern an.
- Unsere Produkte sind für Zehntausende von Zyklen unter normalen Bedingungen ausgelegt. Die Lebensdauer einer Gasfeder hängt jedoch von vielen äußeren Faktoren wie Temperatur, Luftfeuchtigkeit und Umgebung ab.
- Unsere Gasfedern sind komplett wartungsfrei. Bitte die Kolbenstange nicht ölen oder fetten.
- Gasfedern dürfen keinen Querkräften (insbesondere im ausgeschobenen Zustand), Zugkräften, Vibrationen, Mikroschwingungen und hohen Temperaturen ausgesetzt werden.
- Gasfedern dürfen nicht als Endanschlag verwendet werden. Zur Begrenzung des maximalen Öffnungswinkels muss ein entsprechender Endanschlag verwendet werden.
- Die einwandfreie Funktion der Gasfedern wird in erster Linie durch die richtige Abdichtung und die Kolbenstangenoberfläche gewährleistet, die gemeinsam dafür sorgen, dass der Gasdruck im Zylinder erhalten bleibt. Jede Beschädigung der Kolbenstangenoberfläche kann zum Verlust der Funktionalität führen. Schützen Sie die Kolbenstange vor Stößen, Schmutz und Kratzern.
- Der Einbau von unvollständigen Gasfedern und /oder mit sichtbaren Schäden ist nicht zulässig.
- Gasfedern dürfen nicht verändert werden (z.B. Kürzen, Verlängern, Lackieren, Schweißen), Eingriffe in die Federkonstruktion, Erhitzen, Schleifen, Öffnen oder Bohren, Entfernen von Bedruckungen, Austausch von Verbindungselementen, etc.
- Die Gasfeder sollte im ausgeschobenen Zustand gemäß den dargestellten Skizzen montiert und demontiert werden. Es ist nicht zulässig, die komprimierte oder teilweise komprimierte Feder zu demontieren.
- Bei der Montage und Demontage der Feder sind die allgemeinen Sicherheitsvorschriften zu beachten.

## BEZPIECZEŃSTWO I OBSŁUGA

Wysokiej jakości sprężyny gazowe z FA Krosno zapewniają komfort i bezpieczeństwo w naszym codziennym życiu w niezliczonej liczbie zastosowań. Zostały one zaprojektowane w celu zredukowania ludzkiego wysiłku podczas otwierania kłap, podnoszeniu luków, czyniąc ruchy tych elementów gładkimi i w pełni kontrolowanymi. Wysokiej jakości komponenty i solidna konstrukcja sprawiają, że sprężyny gazowe mogą być naszym niezawodnym towarzyszem przez lata.

Nasze sprężyny gazowe są testowane zanim zostaną wysłane z fabryki. Testowanie stanowi istotny etap gwarantujący doskonałą jakość naszych produktów, a jednocześnie pozwala zweryfikować, czy wszystkie wymagania klienta zostały spełnione.

Projektując urządzenie wykorzystujące sprężynę gazową proszę zwrócić uwagę na istotne zasady bezpiecznego i długotrwałego użytkowania sprężyn gazowych.

- Nigdy nie próbuj otwierać sprężyny gazowej. Sprężyny gazowe są wypełnione azotem, który jako naturalnie zawarty w powietrzu jest gazem bezpiecznym. Ponieważ jednak cylinder może być napełniony azotem pod ciśnieniem do 200 barów - wszelkie działania mające na celu zmniejszenie ciśnienia wewnątrz cylindra mogłyby spowodować poważne obrażenia ciała, szkody majątkowe, a nawet stać się przyczyną śmierci.
- Standardowe sprężyny gazowe są przeznaczone do stosowania w zakresie temperatur od -30 ° C do + 80 ° C. Dla innych zakresów temperatur oferujemy specjalne sprężyny gazowe.
- Nasze produkty są zaprojektowane w taki sposób, aby wytrzymały co najmniej dziesiątki tysięcy cykli w standardowych warunkach. Żywotność sprężyny gazowej zależy od wielu czynników zewnętrznych, takich jak temperatura, wilgotność i jakość powietrza.
- Sprężyny gazowe są urządzeniami bezobsługowymi i nie wymagają żadnych czynności serwisowych. Nie należy smarować lub oliwić tłoczyska.
- Nie wolno narażać sprężyn gazowych na naprężenia rozciągające oraz gńące, drgania, a zwłaszcza na gwałtowne rozciąganie czy długotrwałe działanie wysokich temperatur.
- Sprężyny gazowe nie mogą być używane jako ograniczniki maksymalnego otwarcia. Jeżeli zachodzi taka potrzeba należy zastosować ograniczniki końcowe.
- Prawidłowe działanie sprężyn gazowych jest zagwarantowane przez odpowiednie uszczelnienie i gładkość powierzchni tłoczyska. Czynniki te pozwalają na utrzymanie odpowiedniego ciśnienia wewnątrz cylindra. Każde mechaniczne uszkodzenie powierzchni tłoczyska może prowadzić do utraty funkcjonalności, dlatego należy chronić tłoczysko przed uderzeniami, brudem i zadrapaniami.
- Niedopuszczalna jest instalacja sprężyn gazowych z widocznymi uszkodzeniami i/lub niekompletnych.
- Sprężyny gazowe nie mogą podlegać żadnym modyfikacjom (np. skracaniu, wydłużaniu, zmniejszaniu lub powiększaniu średnic, malowaniu, spawaniu), ingerencji w konstrukcję sprężyny, ogrzewaniu, szlifowaniu, otwieraniu lub wierceniu, usuwaniu nadruków, wymianie elementów łączących itp.
- Sprężynę gazową należy montować i demontować w stanie rozciągniętym zgodnie z przedstawionymi szkicami. Nie wolno demontować zamkniętej lub częściowo ściśniętej sprężyny.
- Podczas montażu i demontażu sprężyny należy przestrzegać podstawowych zasad bezpieczeństwa.



## RECOMMENDED INSTALLATION MODE FOR HYDRAULIC DAMPING GAS SPRINGS

Empfohlene Einbauweise für hydraulisch dämpfende Gasfedern

Zalecany sposób montażu sprężyn z hydraulicznym tłumieniem

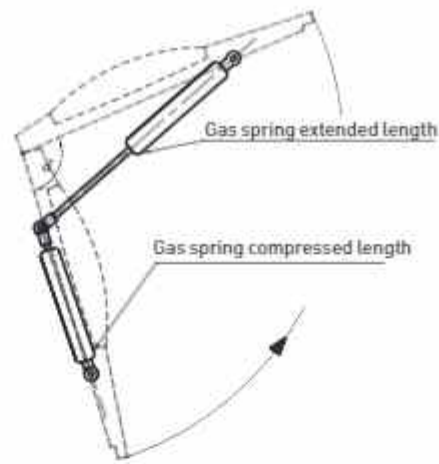

## RECOMMENDED INSTALLATION MODE FOR DYNAMIC DAMPING GAS SPRINGS

Empfohlene Einbauweise für dynamisch dämpfende Gasfedern

Zalecany sposób montażu sprężyn z dynamicznym tłumieniem

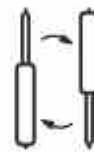

ENG Dynamic damping is independent of the installation direction

DE Die dynamische Dämpfung ist unabhängig von der Montage-richtung.

PL Tłumienie dynamiczne działa niezależnie od pozycji montażu sprężyny gazowej.

## DISASSEMBLING OF BALL SOCKET

Insert a screwdriver (approx. 5 mm wide) into the space between the metal clip and the mounting.  
Raise the clip sufficiently to lift the mounting off the ball stud

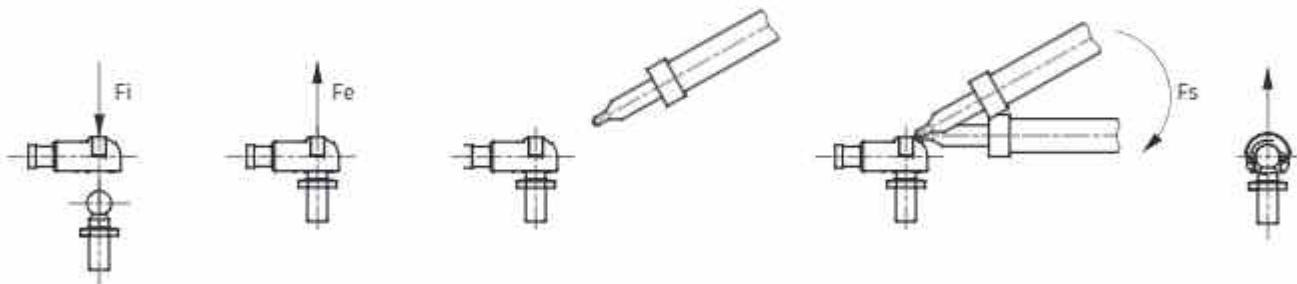

ENG

Fi insertion force  
Fe extraction force  
Fs dismount force

DE

Fi Empreskraft  
Fe Ausziehkraft  
Fs Demontagekraft

PL

Fi siła wciśnięcia  
Fe siła wrywania  
Fs siła demontażu

DE

## DEMONTAGE VON KUGELPFANNEN

Führen Sie einen Schraubendreher (ca. 5 mm breit) in den Spalt zwischen Metallclip und Kugelpfanne ein. Heben Sie den Clip entsprechend an, um die Kugelpfanne vom Kugelbolzen anzuheben.

PL

## DEMONTAŻ SWORZNIA KULOWEGO

Włóż śrubokręt (o szerokości ok 5 mm) w pustą przestrzeń pomiędzy klamrą a gniazdem. Śrubokrętem podważ klamrę w stopniu umożliwiającym zdjęcie gniazda ze sworznia.

# TRANSPORT AND STORAGE

- It is not permissible to store gas springs in the same room as caustic, oxidizing materials and other materials which affect condition.
- It is recommended to store gas springs in roofed rooms that protect against atmospheric influences (in temperature 5 - 35° C and relative humidity  $\leq 70\%$ ).
- It is recommended to store the springs in a vertical position with the piston rod pointing downwards.
- Gas springs must be transported by covered means of transport.
- Gas springs must be protected against damage during transport.

DE

## TRANSPORT UND LAGERUNG

- Eine Lagerung von Gasfedern in einem Raum zusammen mit ätzenden, oxidierenden und anderen Stoffen, die die Gasfedern negativ beeinflussen können, ist nicht zulässig.
- Es wird empfohlen, Gasfedern in überdachten Räumen zu lagern, die vor Witterungseinflüssen schützen (bei 5 - 35 ° C und relativer Luftfeuchtigkeit  $\leq 70\%$ ).
- Es wird empfohlen, die Gasfedern möglichst senkrecht mit der Kolbenstange nach unten zu lagern.
- Gasfedern sind mit abgedeckten Transportmitteln zu transportieren, um vor Transportschaden geschützt zu werden.

PL

## TRANSPORT I PRZECHOWYWANIE

- Nie wolno przechowywać sprężyn gazowych w jednym pomieszczeniu z materiałami wpływającymi na ich stan (z substancjami żrącymi lub silnie utleniającymi).
- Zaleca się przechowywanie sprężyn gazowych w zadaszonych pomieszczeniach, które chronią przed wpływami atmosferycznymi (w temperaturze 5 - 35 ° C i wilgotności względnej  $\leq 70\%$ ).
- Zaleca się przechowywanie sprężyn w pozycji pionowej z tłoczyskiem skierowanym w dół.
- Sprężyny gazowe należy przewozić krytymi środkami transportu. Sprężyny gazowe należy zabezpieczyć przed uszkodzeniem podczas transportu.

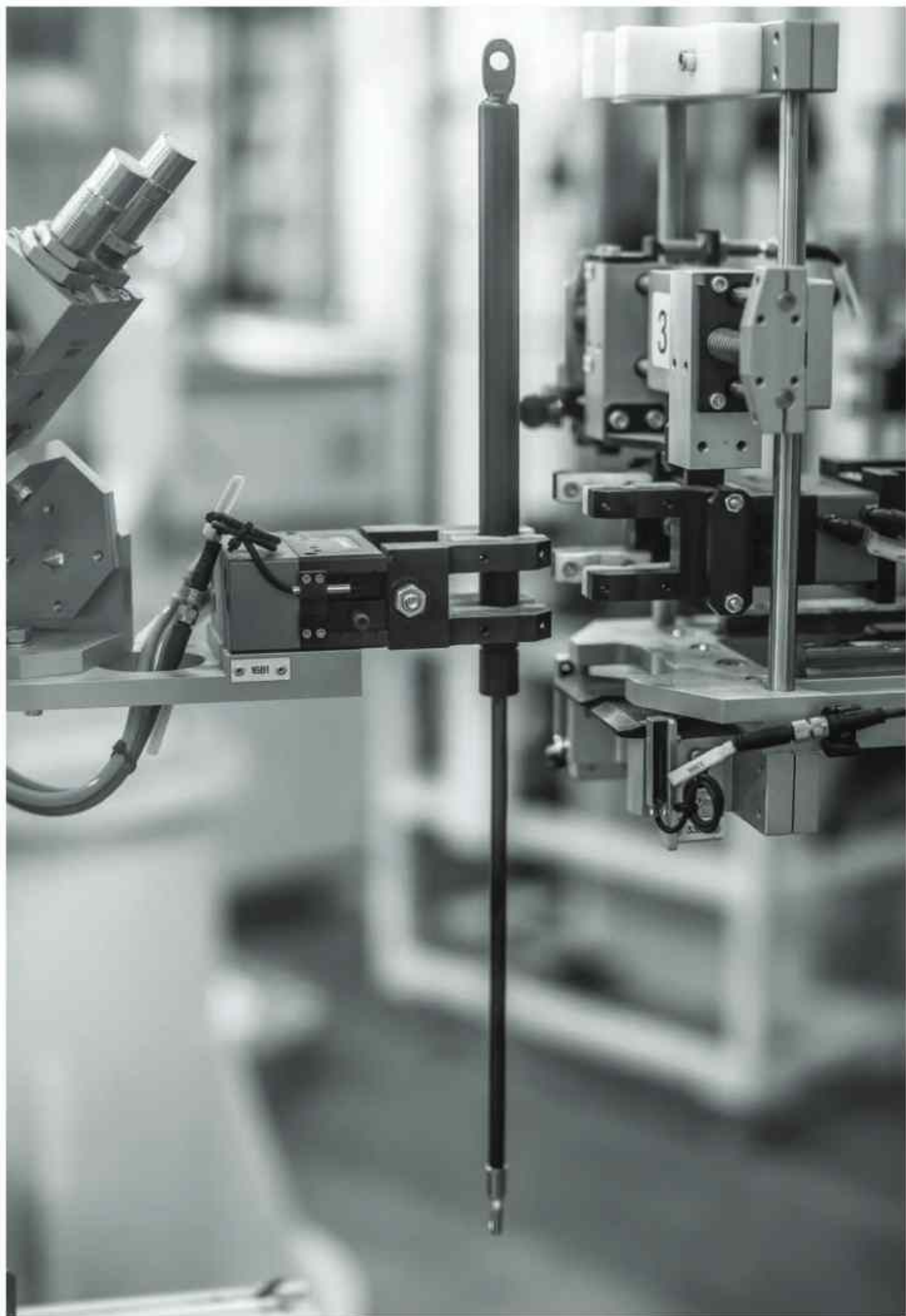





# FA-RISE GAS SPRINGS

**FA-RISE** gas springs are widely used as an aid while lifting and a support while maintaining the open or closed position of different loads.

**FA-RISE** gas springs design provides proper piston rod speed and dumping force at the end of stroke. This secures soft, gentle movement of lifted elements.

DE

## GASDRUCKFEDERN

**FA-RISE** Gasfedern werden überall dort eingesetzt, wo unterschiedlichste Lasten in festgelegten Positionen gehoben, bewegt und abgestützt werden sollen. Die **FA-RISE** - Gasfederkonstruktionen bieten eine optimale Ausfahrgeschwindigkeit und Dämpfung, um einen hohen Komfort in einem weit gefassten Anwendungsbereich zu gewährleisten.

PL

## PCHAJĄCE SPRĘŻYNY GAZOWE FA-RISE

Sprężyny pchające **FA-RISE** są szeroko stosowane jako pomoc przy podnoszeniu oraz opuszczaniu ruchomych klap, schowków i rewizji. Prawidłowo zaprojektowane sprężyny **FA-RISE** zapewnią właściwą prędkość wysuwu tłoczyska i odpowiednie tłumienie w końcowym biegu skoku, sprawiają, że ruch różnego rodzaju pokryw stanie się łatwy, komfortowy i bezpieczny. Występują zarówno z tłumieniem hydraulicznym, jak i z dynamicznym - obydwie typy tłumienia mają swoje zastosowania.

# 6/15

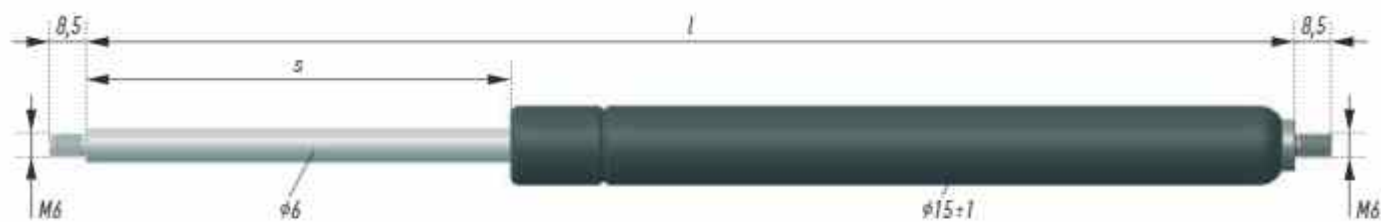



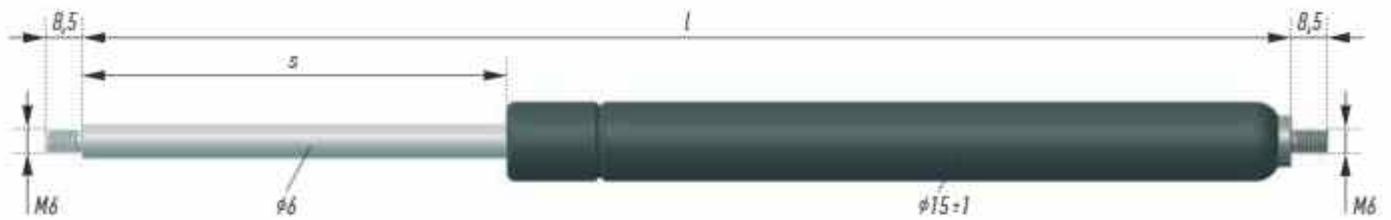

s STROKE (MM)	l EXT. LENGTH (MM)	F <sub>1</sub> EXT. FORCE (N)	 ORDER NO.
<b>20</b>	<b>71</b>	50	5110001
		75	5110002
		100	5110003
		125	5110004
		150	5110005
		175	5110006
		200	5110007
		225	5110008
		250	5110009
		275	5110010
		300	5110011
		325	5110012
		350	5110013
		375	5110014
		400	5110015
<b>40</b>	<b>111</b>	50	5110016
		75	5110017
		100	5110018
		125	5110019
		150	5110020
		175	5110021
		200	5110022
		225	5110023
		250	5110024
		275	5110025
		300	5110026
		325	5110027
		350	5110028
		375	5110029
		400	5110030
<b>50</b>	<b>131</b>	50	5110031
		75	5110032
		100	5110033
		125	5110034
		150	5110035
		175	5110036
		200	5110037
		225	5110038
		250	5110039
		275	5110040
		300	5110041
		325	5110042
		350	5110043
		375	5110044
		400	5110045

s STROKE (MM)	l EXT. LENGTH (MM)	F <sub>1</sub> EXT. FORCE (N)	 ORDER NO.
<b>60</b>	<b>155</b>	50	5110046
		75	5110047
		100	5110048
		125	5110049
		150	5110050
		175	5110051
		200	5110052
		225	5110053
		250	5110054
		275	5110055
		300	5110056
		325	5110057
		350	5110058
		375	5110059
		400	5110060
<b>80</b>	<b>195</b>	50	5110061
		75	5110062
		100	5110063
		125	5110064
		150	5110065
		175	5110066
		200	5110067
		225	5110068
		250	5110069
		275	5110070
		300	5110071
		325	5110072
		350	5110073
		375	5110074
		400	5110075

# 6/15



 $s$ STROKE (MM)	 $l$ EXT. LENGTH (MM)	 $F_1$ EXT. FORCE F1 (N)	 ORDER NO.
<b>100</b>	<b>235</b>	50	5110076
		75	5110077
		100	5110078
		125	5110079
		150	5110080
		175	5110081
		200	5110082
		225	5110083
		250	5110084
		275	5110085
		300	5110086
		325	5110087
		350	5110088
		375	5110089
400	5110090		
<b>120</b>	<b>275</b>	50	5110090
		75	5110091
		100	5110092
		125	5110093
		150	5110094
		175	5110095
		200	5110096
		225	5110097
		250	5110098
		275	5110099
		300	5110100
		325	5110101
		350	5110102
		375	5110103
400	5110104		
<b>150</b>	<b>335</b>	50	5110105
		75	5110106
		100	5110107
		125	5110108
		150	5110109
		175	5110110
		200	5110111
		225	5110112
		250	5110113
		275	5110114
		300	5110115
		325	5110116
		350	5110117
		375	5110118
400	5110119		

 $s$ STROKE (MM)	 $l$ EXT. LENGTH (MM)	 $F_1$ EXT. FORCE F1 (N)	 ORDER NO.
<b>175</b>	<b>395</b>	50	5110120
		75	5110121
		100	5110122
		125	5110123
		150	5110124
		175	5110125
		200	5110126
		225	5110127
		250	5110128
		275	5110129
		300	5110130
		325	5110131
		350	5110132
		375	5110133
400	5110134		
<b>200</b>	<b>445</b>	50	5110135
		75	5110136
		100	5110137
		125	5110138
		150	5110139
		175	5110140
		200	5110141
		225	5110142
		250	5110143
		275	5110144
		300	5110145
		325	5110146
		350	5110147
		375	5110148
400	5110149		

1 N For further gas spring solutions tailored to your application, please contact us. A wide range of mountings can be found on pages 27/28.

1 N Weitere auf Ihre Anwendung abgestimmte Gasfedern bieten wir Ihnen gerne an. Eine breite Auswahl an passenden Anschlussstücken finden Sie auf Seite 27/28.



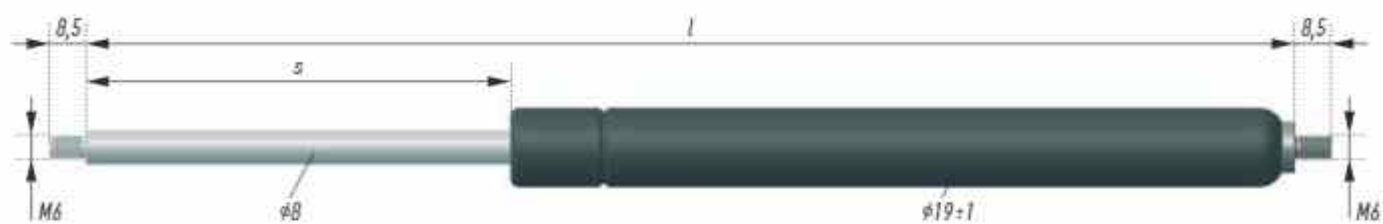

1 N W celu uzyskania informacji dotyczących sprężyn gazowych dopasowanych do konkretnego zastosowania, prosimy o kontakt. Szeroki zakres mocowań znajduje się na stronach 27/28.

**FA-RISE** GAS SPRINGS / GASDRUCKFEDERN / SPRĘŻYNY GAZOWE

# 8/19



 <b>s</b> STROKE (MM)	 <b>l</b> EXT. LENGTH (MM)	 <b>F1</b> EXT. FORCE F1 (N)	 <b>ORDER NO.</b>
<b>20</b>	<b>78</b>	100	5220001
		150	5220002
		200	5220003
		250	5220004
		300	5220005
		350	5220006
		400	5220007
		450	5220008
		500	5220009
		550	5220010
		600	5220011
		650	5220012
		700	5220013
		750	5220014
		800	5220015
<b>50</b>	<b>138</b>	100	5220016
		150	5220017
		200	5220018
		250	5220019
		300	5220020
		350	5220021
		400	5220022
		450	5220023
		500	5220024
		550	5220025
		600	5220026
		650	5220027
		700	5220028
		750	5220029
		800	5220030
<b>60</b>	<b>158</b>	100	5220031
		150	5220032
		200	5220033
		250	5220034
		300	5220035
		350	5220036
		400	5220037
		450	5220038
		500	5220039
		550	5220040
		600	5220041
		650	5220042
		700	5220043
		750	5220044
		800	5220045

 <b>s</b> STROKE (MM)	 <b>l</b> EXT. LENGTH (MM)	 <b>F1</b> EXT. FORCE F1 (N)	 <b>ORDER NO.</b>
<b>80</b>	<b>203</b>	100	5220046
		150	5220047
		200	5220048
		250	5220049
		300	5220050
		350	5220051
		400	5220052
		450	5220053
		500	5220054
		550	5220055
		600	5220056
		650	5220057
		700	5220058
		750	5220059
		800	5220060
<b>100</b>	<b>243</b>	100	5220061
		150	5220062
		200	5220063
		250	5220064
		300	5220065
		350	5220066
		400	5220067
		450	5220068
		500	5220069
		550	5220070
		600	5220071
		650	5220072
		700	5220073
		750	5220074
		800	5220075



**FA-RISE** GAS SPRINGS / GASDRUCKFEDERN / SPRĘŻYNY GAZOWE

# 8/19

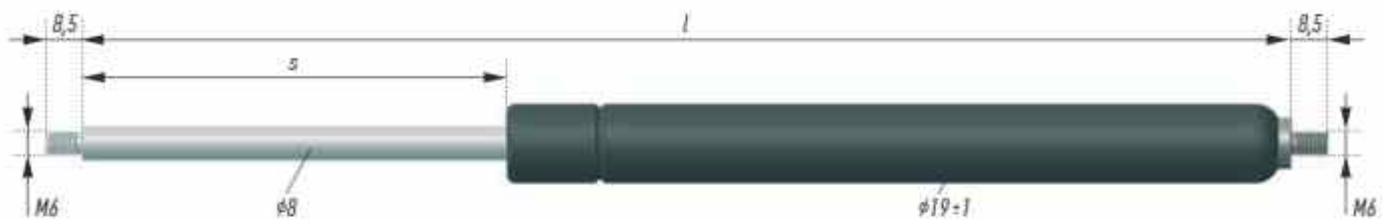

STROKE (MM)	EXT. LENGTH (MM)	EXT. FORCE F1 (N)	ORDER NO.
<b>125</b>	<b>293</b>	100	5220076
		150	5220077
		200	5220078
		250	5220079
		300	5220080
		350	5220081
		400	5220082
		450	5220083
		500	5220084
		550	5220085
		600	5220086
		650	5220087
		700	5220088
		750	5220089
800	5220090		
<b>140</b>	<b>323</b>	100	5220091
		150	5220092
		200	5220093
		250	5220094
		300	5220095
		350	5220096
		400	5220097
		450	5220098
		500	5220099
		550	5220100
		600	5220101
		650	5220102
		700	5220103
		750	5220104
800	5220105		
<b>160</b>	<b>363</b>	100	5220106
		150	5220107
		200	5220108
		250	5220109
		300	5220110
		350	5220111
		400	5220112
		450	5220113
		500	5220114
		550	5220115
		600	5220116
		650	5220117
		700	5220118
		750	5220119
800	5220120		

STROKE (MM)	EXT. LENGTH (MM)	EXT. FORCE F1 (N)	ORDER NO.
<b>175</b>	<b>393</b>	100	5220121
		150	5220122
		200	5220123
		250	5220124
		300	5220125
		350	5220126
		400	5220127
		450	5220128
		500	5220129
		550	5220130
		600	5220131
		650	5220132
		700	5220133
		750	5220134
800	5220135		
<b>200</b>	<b>443</b>	100	5220136
		150	5220137
		200	5220138
		250	5220139
		300	5220140
		350	5220141
		400	5220142
		450	5220143
		500	5220144
		550	5220145
		600	5220146
		650	5220147
		700	5220148
		750	5220149
800	5220150		

# 8/19

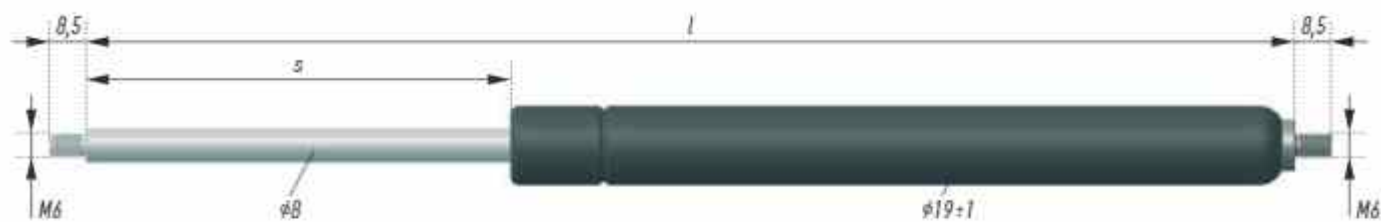

s STROKE (MM)	l EXT. LENGTH (MM)	F <sub>1</sub> EXT. FORCE F <sub>1</sub> (N)	 ORDER NO.
<b>220</b>	<b>483</b>	100	5220151
		150	5220152
		200	5220153
		250	5220154
		300	5220155
		350	5220156
		400	5220157
		450	5220158
		500	5220159
		550	5220160
		600	5220161
		650	5220162
		700	5220163
		750	5220164
800	5220165		
<b>250</b>	<b>553</b>	100	5220166
		150	5220167
		200	5220168
		250	5220169
		300	5220170
		350	5220171
		400	5220172
		450	5220173
		500	5220174
		550	5220175
		600	5220176
		650	5220177
		700	5220178
		750	5220179
800	5220180		
<b>275</b>	<b>603</b>	100	5220181
		150	5220182
		200	5220183
		250	5220184
		300	5220185
		350	5220186
		400	5220187
		450	5220188
		500	5220189
		550	5220190
		600	5220191
		650	5220192
		700	5220193
		750	5220194
800	5220195		

s STROKE (MM)	l EXT. LENGTH (MM)	F <sub>1</sub> EXT. FORCE F <sub>1</sub> (N)	 ORDER NO.
<b>300</b>	<b>653</b>	100	5220196
		150	5220197
		200	5220198
		250	5220199
		300	5220200
		350	5220201
		400	5220202
		450	5220203
		500	5220204
		550	5220205
		600	5220206
		650	5220207
		700	5220208
		750	5220209
800	5220210		
<b>350</b>	<b>753</b>	100	5220211
		150	5220212
		200	5220213
		250	5220214
		300	5220215
		350	5220216
		400	5220217
		450	5220218
		500	5220219
		550	5220220
		600	5220221
		650	5220222
		700	5220223
		750	5220224
800	5220225		

1) N For further gas spring solutions tailored to your application, please contact us. A wide range of mountings can be found on pages 21/28

2) Weitere auf Ihre Anwendung abgestimmte Gasfedern bieten wir Ihnen gerne an. Eine breite Auswahl an passenden Anschlussteilen finden Sie auf Seite 21/28

3) W celu uzyskania informacji dotyczących sprężyn gazowych dopasowanych do konkretnego zastosowania, prosimy o kontakt. Szeroki zakres mocowań znajduje się na stronach 21/28

FA-MOUNTINGS / BEFESTIGUNGSELEMENTE / MOCOWANIA

# 6/15 & 8/19

EYELET / AUGE / UCHWYT OCZKOWY

ORDER NO.	DIMENSIONS REGARDING SKETCH							SW	MATERIAL
	a	b	c	d	e	f			
0025611	6,1	18	10	M6	-	18	-	Z	
0025612	8,1	19	10	M6	-	18	-	Z	



EYELET / AUGE / UCHWYT OCZKOWY

ORDER NO.	DIMENSIONS REGARDING SKETCH							SW	MATERIAL
	a	b	c	d	e	f			
0025319	6,1	21	3	M6	9	13	-	SZ	
0025342	8,1	22	3	M6	10	13	-	SZ	
0025009	8,1	28	5	M6	12	15	-	SZ	

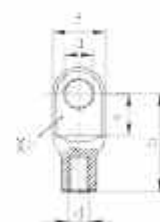

EYELET / AUGE / UCHWYT OCZKOWY

ORDER NO.	DIMENSIONS REGARDING SKETCH							SW	MATERIAL
	a	b	c	d	e	f			
0025613	8,1	25	10	M6	-	17	-	Z	

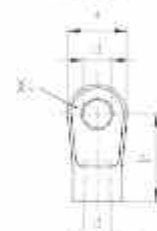

CLEVIS WITH BOLT / GABELKOPF MIT BOLZEN / GŁÓWICA WIDŁAKOWA ZE SWORZNIEM

ORDER NO.	DIMENSIONS REGARDING SKETCH							SW	MATERIAL
	a	b	c	d	e	f			
0025614	6	24	6	M6	12	-	-	SZ	

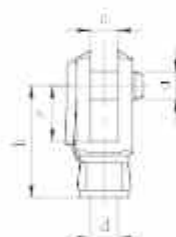

ANGLE JOINT / WINKELGELENK / ŁĄCZE PRZEGUBOWE

ORDER NO.	DIMENSIONS REGARDING SKETCH							SW	MATERIAL
	a	b	c	d	e	f			
0026541	M6	10	19	M6	10	12	13	P+SZ	
0026542	M6	10	19	M6	10	12	13	SZ+SZ	
0026543	M8	15	19	M6	10	17	13	SI+SZ	
0026544	M6	10	25	M6	10	12	13	SI+SZ	
0026545	M8	15	25	M6	10	17	13	SI+SZ	

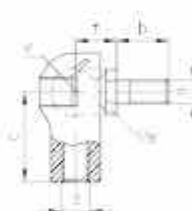

ANGLE JOINT / WINKELGELENK / ŁĄCZE PRZEGUBOWE

ORDER NO.	DIMENSIONS REGARDING SKETCH							SW	MATERIAL
	a	b	c	d	e	f			
0026546	M6	10	19	M6	10	12	13	SI+SZ	
0026547	M6	10	25	M6	10	12	13	SI+SZ	
0026548	M8	15	19	M6	10	17	13	SI+SZ	
0026549	M8	15	25	M6	10	17	13	SI+SZ	

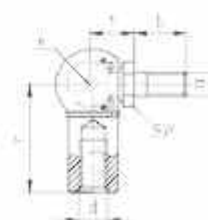

FA-MOUNTINGS / BEFESTIGUNGSELEMENTE / MOCOWANIA

# 6/15 & 8/19

ANGLE JOINT / WINKELGELENK / ŁĄCZE PRZEGUBOWE

DRIVER NO.	DIMENSIONS REGARDING SKETCH							SW	MATERIAL
	a	b	c	d	e	f			
0026550	M6	10	19	M6	10	12	13	P+SZ	
0026551	M8	15	19	M6	10	17	13	P+SZ	

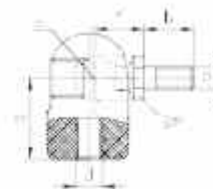

BALL SOCKET / KUGELPFANNE / GNIAZDO PRZEGUBU

DRIVER NO.	DIMENSIONS REGARDING SKETCH							SW	MATERIAL
	a	b	c	d	e	f			
0026102	-	-	19	M6	10	-	-	P	
0022078	-	-	19	M6	10	-	-	SI	
0025615	-	-	25	M6	10	-	-	SZ	



BALL SOCKET / KUGELPFANNE / GNIAZDO PRZEGUBU

DRIVER NO.	DIMENSIONS REGARDING SKETCH							SW	MATERIAL
	a	b	c	d	e	f			
0022265	-	-	19	M6	10	-	-	SZ	
0025616	-	-	25	M6	10	-	-	SZ	



BALL SOCKET / KUGELPFANNE / GNIAZDO PRZEGUBU

DRIVER NO.	DIMENSIONS REGARDING SKETCH							SW	MATERIAL
	a	b	c	d	e	f			
0026045	-	-	19	M6	10	-	-	P	

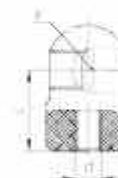

DUST CAP / STAUBSCHUTZKAPPE / KOŁPAK OCHRONNY

DRIVER NO.	DIMENSIONS REGARDING SKETCH							SW	MATERIAL
	a	b	c	d	e	f			
0025203	8	32	20	-	-	-	-	P	



ENG

$\frac{X}{X}$	material thickness
A	aluminum
SZ	steel zinc coated
SI	steel zinc iron coated
SX	stainless steel
P	plastic
Z	zinc die-cast zinc coated

DE

$\frac{X}{X}$	Materialdicke
A	Aluminium
SZ	Stahl verzinkt
SI	Stahl zinkisenbeschichtet
SX	Edelstahl
P	Kunststoff
Z	Zinkdruckguss verzinkt

PL

$\frac{X}{X}$	grubość materiału
A	aluminium
SZ	stal (biały ocynk)
SI	stal (czarny ocynk)
SX	stal nierdzewna
P	plastik
Z	odlew cynkalowy (biały ocynk)



# 10/22

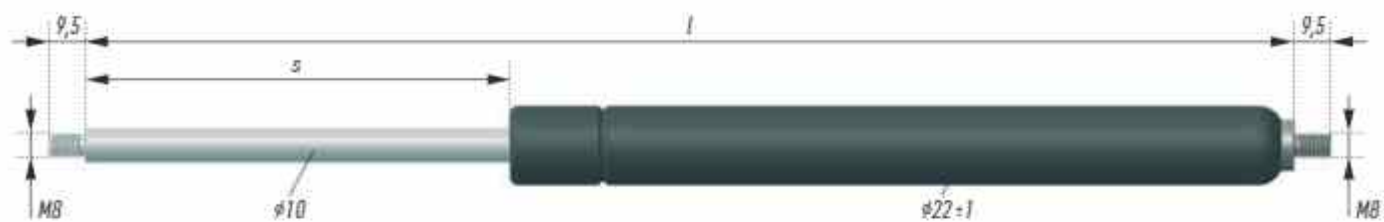



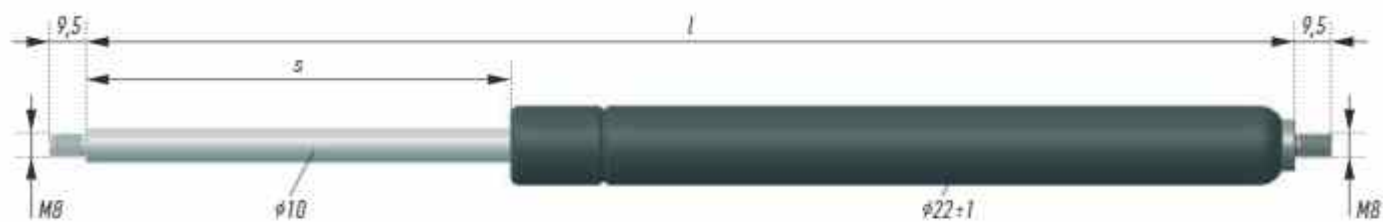

s STROKE (MM)	l EXT. LENGTH (MM)	F <sub>1</sub> EXT. FORCE (N)	 ORDER NO.
<b>45</b>	<b>132</b>	150	5330001
		200	5330002
		300	5330003
		400	5330004
		500	5330005
		600	5330006
		700	5330007
		800	5330008
		900	5330009
		1000	5330010
		1100	5330011
		1200	5330012
		1300	5330013
<b>80</b>	<b>202</b>	150	5330016
		200	5330017
		300	5330018
		400	5330019
		500	5330020
		600	5330021
		700	5330022
		800	5330023
		900	5330024
		1000	5330025
		1100	5330026
		1200	5330027
		1300	5330028
<b>100</b>	<b>242</b>	150	5330031
		200	5330032
		300	5330033
		400	5330034
		500	5330035
		600	5330036
		700	5330037
		800	5330038
		900	5330039
		1000	5330040
		1100	5330041
		1200	5330042
		1300	5330043

s STROKE (MM)	l EXT. LENGTH (MM)	F <sub>1</sub> EXT. FORCE (N)	 ORDER NO.
<b>125</b>	<b>292</b>	150	5330046
		200	5330047
		300	5330048
		400	5330049
		500	5330050
		600	5330051
		700	5330052
		800	5330053
		900	5330054
		1000	5330055
		1100	5330056
		1200	5330057
		1300	5330058
<b>150</b>	<b>342</b>	150	5330061
		200	5330062
		300	5330063
		400	5330064
		500	5330065
		600	5330066
		700	5330067
		800	5330068
		900	5330069
		1000	5330070
		1100	5330071
		1200	5330072
		1300	5330073

# 10/22



 <b>s</b> STROKE (MM)	 <b>l</b> EXT. LENGTH (MM)	 EXT. FORCE F1 (N)	 ORDER NO.
<b>160</b>	<b>362</b>	150	5330076
		200	5330077
		300	5330078
		400	5330079
		500	5330080
		600	5330081
		700	5330082
		800	5330083
		900	5330084
		1000	5330085
		1100	5330086
		1200	5330087
		1300	5330088
<b>175</b>	<b>392</b>	150	5330091
		200	5330092
		300	5330093
		400	5330094
		500	5330095
		600	5330096
		700	5330097
		800	5330098
		900	5330099
		1000	5330100
		1100	5330101
		1200	5330102
		1300	5330103
<b>200</b>	<b>442</b>	150	5330106
		200	5330107
		300	5330108
		400	5330109
		500	5330110
		600	5330111
		700	5330112
		800	5330113
		900	5330114
		1000	5330115
		1100	5330116
		1200	5330117
		1300	5330118

 <b>s</b> STROKE (MM)	 <b>l</b> EXT. LENGTH (MM)	 EXT. FORCE F1 (N)	 ORDER NO.
<b>250</b>	<b>552</b>	150	5330121
		200	5330122
		300	5330123
		400	5330124
		500	5330125
		600	5330126
		700	5330127
		800	5330128
		900	5330129
		1000	5330130
		1100	5330131
		1200	5330132
		1300	5330133
<b>300</b>	<b>652</b>	150	5330136
		200	5330137
		300	5330138
		400	5330139
		500	5330140
		600	5330141
		700	5330142
		800	5330143
		900	5330144
		1000	5330145
		1100	5330146
		1200	5330147
		1300	5330148

# 10/22

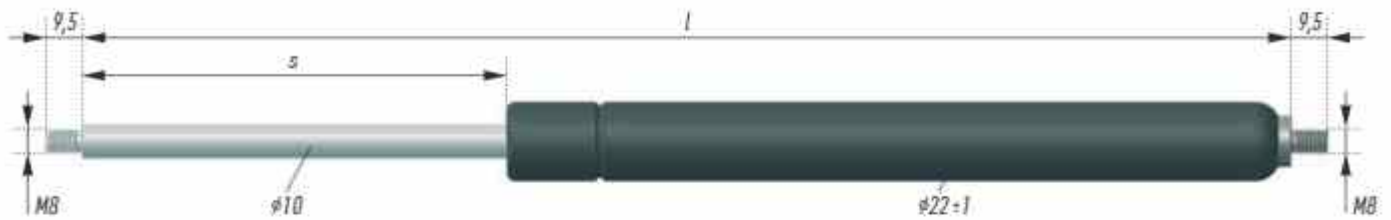

s STROKE (MM)	l EXT. LENGTH (MM)	F <sub>I</sub> EXT. FORCE F <sub>I</sub> (N)	 ORDER NO.
<b>350</b>	<b>752</b>	150	5330151
		200	5330152
		300	5330153
		400	5330154
		500	5330155
		600	5330156
		700	5330157
		800	5330158
		900	5330159
		1000	5330160
		1100	5330161
		1200	5330162
		1300	5330163
<b>390</b>	<b>832</b>	150	5330166
		200	5330167
		300	5330168
		400	5330169
		500	5330170
		600	5330171
		700	5330172
		800	5330173
		900	5330174
		1000	5330175
		1100	5330176
1200	5330177		
1300	5330178		
<b>407</b>	<b>866</b>	150	5330181
		200	5330182
		300	5330183
		400	5330184
		500	5330185
		600	5330186
		700	5330187
		800	5330188
		900	5330189
		1000	5330190
		1100	5330191
1200	5330192		
1300	5330193		

s STROKE (MM)	l EXT. LENGTH (MM)	F <sub>I</sub> EXT. FORCE F <sub>I</sub> (N)	 ORDER NO.
<b>450</b>	<b>952</b>	150	5330196
		200	5330197
		300	5330198
		400	5330199
		500	5330200
		600	5330201
		700	5330202
		800	5330203
		900	5330204
		1000	5330205
		1100	5330206
1200	5330207		
1300	5330208		

1) N For further gas spring solutions tailored to your application, please contact us.  
 1)) Weitere auf Ihre Anwendung abgestimmte Gasfedern bieten wir Ihnen gerne an.  
 1) W celu uzyskania informacji dotyczących sprężyn gazowych dopasowanych do konkretnego zastosowania, prosimy o kontakt.



EYELET / AUGÉ / UCHWYT OCZKOWY

	DIMENSIONS REGARDING SKETCH							SW	MATERIAL
	a	b	c	d	e	f			
0025617	8,1	18	10	M8	-	18	-	Z	
0025619	10,1	19	10	M8	-	19	-	Z	
0022398	8,1	21	17,5	M8	-	18	-	Z	
0025341	10,1	25	18	M8	-	18	-	Z	
0025619	8,1	25	10	M8	-	17	-	Z	



EYELET / AUGÉ / UCHWYT OCZKOWY

	DIMENSIONS REGARDING SKETCH							SW	MATERIAL
	a	b	c	d	e	f			
0025114	8,1	28	5	M8	12	15	-	SZ	

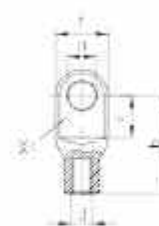

EYELET / AUGÉ / UCHWYT OCZKOWY

	DIMENSIONS REGARDING SKETCH							SW	MATERIAL
	a	b	c	d	e	f			
0025620	8,1	24,5	5	M8	14	12	-	SZ	
0025621	8,1	19	10	M8	14	14	-	SZ	

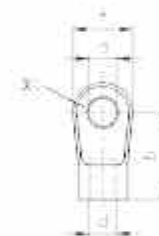

CLEVIS WITH BOLT / GABELKOPF MIT BOLZEN / GŁÓWICA WIDŁAKOWA ZE SWORZNIEM

	DIMENSIONS REGARDING SKETCH							SW	MATERIAL
	a	b	c	d	e	f			
0025622	8	32	8	M8	16	-	-	SZ	
0025623	8	48	8	M8	32	-	-	SZ	



ANGLE JOINT / WINKELGELENK / ŁĄCZE PRZEGUBOWE

	DIMENSIONS REGARDING SKETCH							SW	MATERIAL
	a	b	c	d	e	f			
0026552	M6	10	25	M8	10	12	13	SZ	
0026553	M8	15	25	M8	10	17	13	SZ	

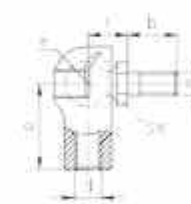

ANGLE JOINT / WINKELGELENK / ŁĄCZE PRZEGUBOWE

	DIMENSIONS REGARDING SKETCH							SW	MATERIAL
	a	b	c	d	e	f			
0026554	M8	16	22	M8	13	13	11	SZ	
0026555	M10	20	22	M8	13	16	17	SZ	
0026556	M8	16	30	M8	13	13	11	SZ	
0026557	M10	20	30	M8	13	16	17	SZ	
0025345	M8	16	30	M8	13	13	11	SZ	

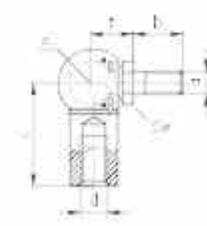

ANGLE JOINT / WINKELGELENK / ŁĄCZE PRZEGUBOWE

ORDER NO.	DIMENSIONS REGARDING SKETCH							MATERIAL*
	a	b	c	d	e	f	sw	
0026558	M6	13	18	M8	10	12	13	P+SZ
0026559	M8	15	18	M8	10	17	13	P+SZ

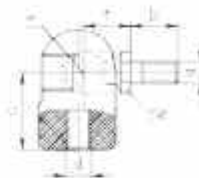

BALL SOCKET / KUGELPFANNE / GNIAZDO PRZEGUBU

ORDER NO.	DIMENSIONS REGARDING SKETCH							MATERIAL
	a	b	c	d	e	f	sw	
0022963	-	-	25	M8	10	-	-	SZ



BALL SOCKET / KUGELPFANNE / GNIAZDO PRZEGUBU

ORDER NO.	DIMENSIONS REGARDING SKETCH							MATERIAL
	a	b	c	d	e	f	sw	
0025624	-	-	19	-	-	-	-	SZ
0025532	-	-	22	M8	13	-	-	SZ
0022873	-	-	30	M8	13	-	-	SZ

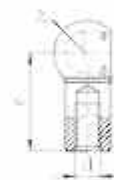

BALL SOCKET / KUGELPFANNE / GNIAZDO PRZEGUBU

ORDER NO.	DIMENSIONS REGARDING SKETCH							MATERIAL
	a	b	c	d	e	f	sw	
0025407	-	-	18	M8	10	-	-	P



DUST CAP / STAUBSCHUTZKAPPE / KŁĘPAK OCHRONNY

ORDER NO.	DIMENSIONS REGARDING SKETCH							MATERIAL
	a	b	c	d	e	f	sw	
0025384	10	38	23,5	-	-	-	-	P



EXTENSION / VERLÄNGERUNG / PRZEDŁUŻKA

ORDER NO.	DIMENSIONS REGARDING SKETCH							MATERIAL
	a	b	c	d	e	f	sw	
0025625	M8	35	12	M8	-	-	-	SI
0025626	M8	60	12	M8	-	-	-	SI

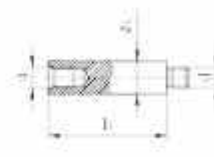

ENG

- T material thickness
- A aluminium
- SZ steel zinc coated
- SI steel zinc iron coated
- SX stainless steel
- P plastic
- Z zinc die-cast zinc coated

DE

- T Materialdicke
- A Aluminium
- SZ Stahl verzinkt
- SI Stahl zinkisenbeschichtet
- SX Edelstahl
- P Kunststoff
- Z Zinkdruckguss verzinkt

PL

- T grubość materiału
- A aluminium
- SZ stal (biały ocynk)
- SI stal (czarny ocynk)
- SX stal nierdzewna
- P plastik
- Z odlew cynkalowy (biały ocynk)

# 14/28

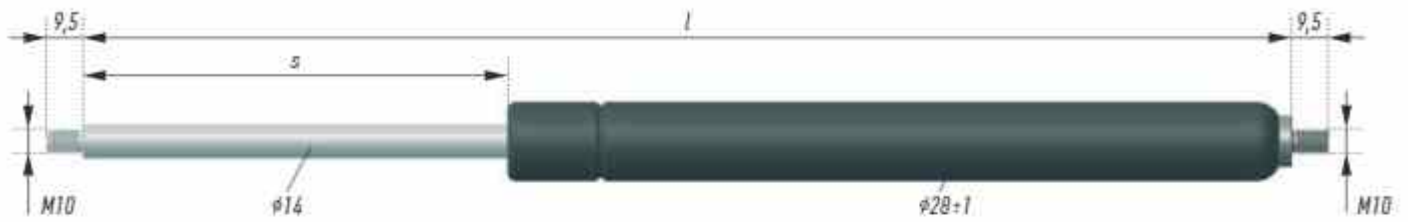



s STROKE (MM)	l EXT. LENGTH (MM)	F <sub>1</sub> EXT. FORCE F <sub>1</sub> (N)	 ORDER NO.
<b>100</b>	<b>245</b>	450	5440001
		500	5440002
		600	5440003
		700	5440004
		750	5440005
		800	5440006
		900	5440007
		1000	5440008
		1100	5440009
		1250	5440010
		1500	5440011
		1750	5440012
		1900	5440013
		2250	5440014
		2500	5440015
<b>150</b>	<b>345</b>	450	5440016
		500	5440017
		600	5440018
		700	5440019
		750	5440020
		800	5440021
		900	5440022
		1000	5440023
		1100	5440024
		1250	5440025
		1500	5440026
		1750	5440027
		1900	5440028
		2250	5440029
		2500	5440030
<b>200</b>	<b>445</b>	450	5440031
		500	5440032
		600	5440033
		700	5440034
		750	5440035
		800	5440036
		900	5440037
		1000	5440038
		1100	5440039
		1250	5440040
		1500	5440041
		1750	5440042
		1900	5440043
		2250	5440044
		2500	5440045





s STROKE (MM)	l EXT. LENGTH (MM)	F <sub>1</sub> EXT. FORCE F <sub>1</sub> (N)	 ORDER NO.
<b>250</b>	<b>545</b>	450	5440046
		500	5440047
		600	5440048
		700	5440049
		750	5440050
		800	5440051
		900	5440052
		1000	5440053
		1100	5440054
		1250	5440055
		1500	5440056
		1750	5440057
		1900	5440058
		2250	5440059
		2500	5440060
<b>275</b>	<b>595</b>	450	5440061
		500	5440062
		600	5440063
		700	5440064
		750	5440065
		800	5440066
		900	5440067
		1000	5440068
		1100	5440069
		1250	5440070
		1500	5440071
		1750	5440072
		1900	5440073
		2250	5440074
		2500	5440075
<b>300</b>	<b>645</b>	450	5440076
		500	5440077
		600	5440078
		700	5440079
		750	5440080
		800	5440081
		900	5440082
		1000	5440083
		1100	5440084
		1250	5440085
		1500	5440086
		1750	5440087
		1900	5440088
		2250	5440089
		2500	5440090



# 14/28



 <b>s</b> STROKE (MM)	 <b>l</b> EXT. LENGTH (MM)	 EXT. FORCE F1 (N)	 ORDER NO.
<b>325</b>	<b>705</b>	450	5440091
		500	5440092
		600	5440093
		700	5440094
		750	5440095
		800	5440096
		900	5440097
		1000	5440098
		1100	5440099
		1250	5440100
		1500	5440101
		1750	5440102
		1900	5440103
		2250	5440104
2500	5440105		
<b>350</b>	<b>755</b>	450	5440106
		500	5440107
		600	5440108
		700	5440109
		750	5440110
		800	5440111
		900	5440112
		1000	5440113
		1100	5440114
		1250	5440115
		1500	5440116
		1750	5440117
		1900	5440118
		2250	5440119
2500	5440120		
<b>375</b>	<b>805</b>	450	5440121
		500	5440122
		600	5440123
		700	5440124
		750	5440125
		800	5440126
		900	5440127
		1000	5440128
		1100	5440129
		1250	5440130
		1500	5440131
		1750	5440132
		1900	5440133
		2250	5440134
2500	5440135		

 <b>s</b> STROKE (MM)	 <b>l</b> EXT. LENGTH (MM)	 EXT. FORCE F1 (N)	 ORDER NO.
<b>395</b>	<b>845</b>	450	5440136
		500	5440137
		600	5440138
		700	5440139
		750	5440140
		800	5440141
		900	5440142
		1000	5440143
		1100	5440144
		1250	5440145
		1500	5440146
		1750	5440147
		1900	5440148
		2250	5440149
2500	5440150		
<b>450</b>	<b>955</b>	450	5440151
		500	5440152
		600	5440153
		700	5440154
		750	5440155
		800	5440156
		900	5440157
		1000	5440158
		1100	5440159
		1250	5440160
		1500	5440161
		1750	5440162
		1900	5440163
		2250	5440164
2500	5440165		
<b>500</b>	<b>1055</b>	450	5440166
		500	5440167
		600	5440168
		700	5440169
		750	5440170
		800	5440171
		900	5440172
		1000	5440173
		1100	5440174
		1250	5440175
		1500	5440176
		1750	5440177
		1900	5440178
		2250	5440179
2500	5440180		

1 N For further gas spring solutions tailored to your application, please contact us.  
 1) Weitere auf Ihre Anwendung abgestimmte Gasfedern bieten wir Ihnen gerne an.  
 1) W celu uzyskania informacji dotyczących sprężyn gazowych dopasowanych do konkretnego zastosowania, prosimy o kontakt.

# 14/28

EYELET / AUGE / UCHWYT OCZKOWY

 ORDER NO.	DIMENSIONS REGARDING SKETCH							SW	MATERIAL
	a	b	c	d	e	f			
0025627	8,1	16	12	M10	-	19	-	Z	
0025628	10,1	16	12	M10	-	19	-	Z	
0027597	8,1	28	10	M10	-	20	-	SZ	
0025330	10,1	28	10	M10	-	20	-	SZ	
0025346	8,1	28	12	M10	-	20	-	SZ	
0025509	10,1	28	12	M10	-	20	-	SZ	

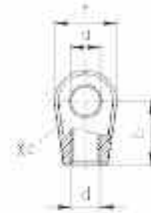

EYELET / AUGE / UCHWYT OCZKOWY

 ORDER NO.	DIMENSIONS REGARDING SKETCH							SW	MATERIAL
	a	b	c	d	e	f			
0025629	8,1	25	18	M10	-	18	-	Z	
0025630	10,1	25	18	M10	-	18	-	Z	



EYELET / AUGE / UCHWYT OCZKOWY

 ORDER NO.	DIMENSIONS REGARDING SKETCH							SW	MATERIAL
	a	b	c	d	e	f			
0025631	8,1	30	10	M10	16	18	-	SZ	
0025632	10,1	30	10	M10	16	18	-	SZ	
0025633	10,1	35	10	M10	16	18	-	SZ	



CLEVIS WITH BOLT / GABELKOPF MIT BOLZEN / GŁOWICA WIDELKOWA ZE SWORZNIEM

 ORDER NO.	DIMENSIONS REGARDING SKETCH							SW	MATERIAL
	a	b	c	d	e	f			
0025634	8	32	8	M10	16	-	-	SZ	
0025635	10	40	10	M10	20	-	-	SZ	
0025636	10	60	10	M10	40	-	-	SZ	



ANGLE JOINT / WINKELGELENK / ŁĄCZE PRZEGUBOWE

 ORDER NO.	DIMENSIONS REGARDING SKETCH							SW	MATERIAL
	a	b	c	d	e	f			
0026580	M10	20	30	M10	16	16	13	SZ	
0026581	M10	20	35	M10	16	16	13	SZ	

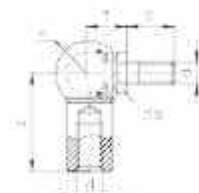

# 14/28

DUST CAP / STAUBSCHUTZKAPPE / KOLPAK OCHRONNY

 ORDER NO.	DIMENSIONS REGARDING SKETCH							MATERIAL
	a	b	c	d	e	f	SW	
0025637	14	42	29	-	-	-	-	P



EXTENSION / VERLÄNGERUNG / PRZEDŁUŻKA

 ORDER NO.	DIMENSIONS REGARDING SKETCH							MATERIAL
	a	b	c	d	e	f	SW	
0025638	M10	25	16	M10	-	-	-	SI
0025639	M10	50	16	M10	-	-	-	SI



ENG

$\frac{W}{T}$	material thickness
A	aluminum
SZ	steel zinc coated
SI	steel zinc iron coated
SX	stainless steel
P	plastic
Z	zinc die-cast zinc coated

DE

$\frac{W}{T}$	Materialdicke
A	Aluminium
SZ	Stahl verzinkt
SI	Stahl zink-eisenbeschichtet
SX	Edelstahl
P	Kunststoff
Z	Zinkdruckguss verzinkt





PL

$\frac{W}{T}$	grubość materiału
A	aluminium
SZ	stal (biały ocynk)
SI	stal (czarny ocynk)
SX	stal nierdzewna
P	plastik
Z	odlew cynkowany (biały ocynk)

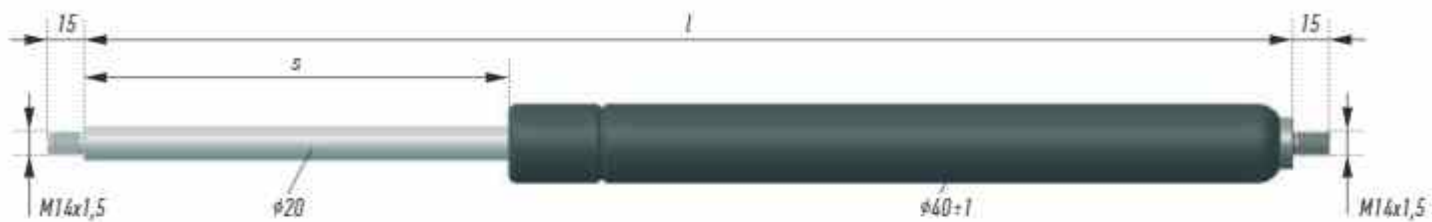
**FA-RISE** GAS SPRINGS / GASDRUCKFEDERN / SPRĘŻYNY GAZOWE

# 20/40



 <b>s</b> STROKE (MM)	 <b>l</b> EXT. LENGTH (MM)	 <b>F<sub>1</sub></b> EXT. FORCE F <sub>1</sub> (N)	 <b>ORDER NO.</b>
<b>100</b>	<b>285</b>	500	5551111
		1000	5551112
		1500	5551113
		2000	5551114
		2500	5551115
		3000	5551116
		3500	5551117
		4000	5551118
		4500	5551119
		5000	5551120
<b>150</b>	<b>385</b>	500	5551121
		1000	5551122
		1500	5551123
		2000	5551124
		2500	5551125
		3000	5551126
		3500	5551127
		4000	5551128
		4500	5551129
		5000	5551130
<b>200</b>	<b>485</b>	500	5551131
		1000	5551132
		1500	5551133
		2000	5551134
		2500	5551135
		3000	5551136
		3500	5551137
		4000	5551138
		4500	5551139
		5000	5551140
<b>250</b>	<b>585</b>	500	5551141
		1000	5551142
		1500	5551143
		2000	5551144
		2500	5551145
		3000	5551146
		3500	5551147
		4000	5551148
		4500	5551149
		5000	5551150

 <b>s</b> STROKE (MM)	 <b>l</b> EXT. LENGTH (MM)	 <b>F<sub>1</sub></b> EXT. FORCE F <sub>1</sub> (N)	 <b>ORDER NO.</b>
<b>300</b>	<b>685</b>	500	5551151
		1000	5551152
		1500	5551153
		2000	5551154
		2500	5551155
		3000	5551156
		3500	5551157
		4000	5551158
		4500	5551159
		5000	5551160
<b>400</b>	<b>885</b>	500	5551161
		1000	5551162
		1500	5551163
		2000	5551164
		2500	5551165
		3000	5551166
		3500	5551167
		4000	5551168
		4500	5551169
		5000	5551170
<b>500</b>	<b>1085</b>	500	5551171
		1000	5551172
		1500	5551173
		2000	5551174
		2500	5551175
		3000	5551176
		3500	5551177
		4000	5551178
		4500	5551179
		5000	5551180
<b>600</b>	<b>1285</b>	500	5551181
		1000	5551182
		1500	5551183
		2000	5551184
		2500	5551185
		3000	5551186
		3500	5551187
		4000	5551188
		4500	5551189
		5000	5551190



# 20/40

## EYELET / AUGEN / UCHWYT OCZKOWY

ORDER NO.	DIMENSIONS REGARDING SKETCH						SW	MATERIAL
	a	b	c	d	e	f		
0025640	14,1	40	14	M14x1,5	21	25	-	SZ



## CLEVIS WITH BOLT / GABELKOPF MIT BOLZEN / GŁOWICA WIDELKOWA ZE SWORZNIEM

ORDER NO.	DIMENSIONS REGARDING SKETCH						SW	MATERIAL
	a	b	c	d	e	f		
0025641	14	56	14	M14x1,5	-	28	-	SZ



## ANGLE JOINT / WINKELGELENK / ŁĄCZE PRZEGUBOWE

ORDER NO.	DIMENSIONS REGARDING SKETCH						SW	MATERIAL
	a	b	c	d	e	f		
0026562	M14	28	45	M14x1,5	19	20	16	SZ

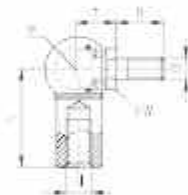

### ENG

2	material thickness
A	aluminium
SZ	steel zinc coated
SI	steel zinc iron coated
SX	stainless steel
P	plastic
Z	zinc die-cast zinc coated

### DE

2	Materialdicke
A	Aluminium
SZ	Stahl verzinkt
SI	Stahl zinkisenbeschichtet
SX	Edelstahl
P	Kunststoff
Z	Zinkdruckguss verzinkt

### PL

2	grubość materiału
A	aluminium
SZ	stal (biały ocynk)
SI	stal (czarny ocynk)
SX	stal nierdzewna
P	plastik
Z	odlew cynkalowy (biały ocynk)

# ADDITIONAL OPTIONS FOR FA-RISE GAS SPRINGS:

## FA-HOLD GAS SPRINGS

**FA-HOLD** gas springs add functionality to a standard gas spring allowing for load positioning along the stroke, without application of an additional mechanism. **FA-HOLD** will control the load within defined limits.

Gas spring characteristic curve

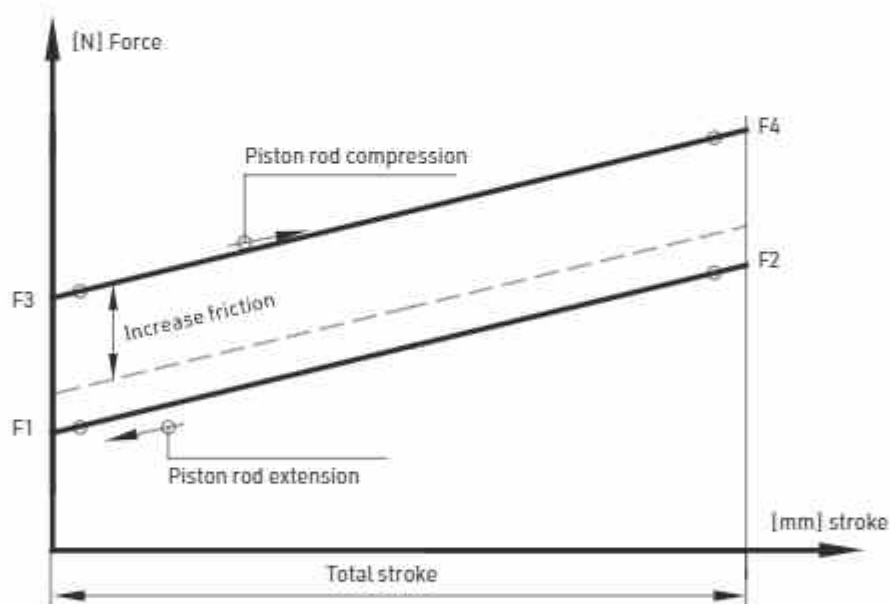

DE

### FA-HOLD GASFEDERN

**FA-HOLD**-Gasfedern ergänzen die Gasdruckfedern um die Funktion der stufenlosen Positionierung der Last entlang des kompletten Hubs. Ohne zusätzlichem Mechanismus!

**FA-HOLD** hält die Anwendung innerhalb definierter Schwellwerte konstant auf Position.

PI

### FA-HOLD

Sprężyny **FA-HOLD** zwiększają funkcjonalność pchającej sprężyny gazowej, umożliwiając pozycjonowanie klapy na długości skoku bez stosowania dodatkowego mechanizmu. Sprężyny

**FA-HOLD** kontrolują obciążenie zgodnie z zadanymi limitami.

# FA-2STAGE GAS SPRINGS

**FA-2STAGE** gas springs combine the benefits of **FA-RISE** pushing gas springs with dynamic damping and the positioning function of the **FA-HOLD**.

**FA-2STAGE** gas springs offer two functional areas along the stroke. A load can be automatically stopped and positioned at a defined point and afterwards manually moved to the next position.

Gas spring characteristic curve

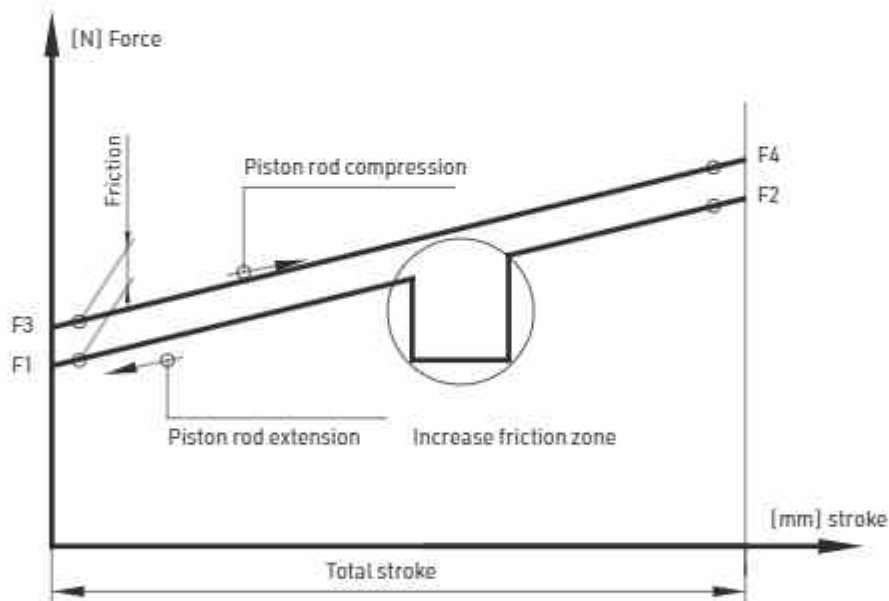

DE

## FA-2STAGE GASFEDERN

**FA-2STAGE** Gasfedern vereinen die Vorteile der **FA-RISE** Gasfedern mit dynamischer Dämpfung plus die Positionierfunktion der **FA-HOLD**. Dabei bieten die **FA-2STAGE** Gasfedern zwei verschiedene Funktionsbereiche entlang des Hubwegs.

Somit kann die Last automatisch an einem definierten Punkt gestoppt, beziehungsweise positioniert und anschließend manuell auf weitere Positionen bewegt werden.

PL

## FA-2STAGE

Sprężyny **FA-2STAGE** łączą funkcje typowe dla pchających sprężyn **FA-RISE** z tłumieniem dynamicznym i sprężyn **FA-HOLD**.

Sprężyny **FA-2STAGE** posiadają dwa obszary funkcjonalne wzdłuż skoku. Ciężar może być automatycznie zatrzymany i umieszczony w danym punkcie, a potem ręcznie przesunięty do kolejnej pozycji.

# SPECIAL AND CUSTOMIZED GAS SPRINGS

**SPEZIAL - UND KUNDENSPEZIFISCHE GASFEDERN  
SPRĘŻYNY SPECJALNE I DOSTOSOWANE DO SZCZEGÓLNYCH WYMAGAŃ KLIENTA**



**FOR AMBIENT TEMPERATURES FROM -40°C TO 200°C**  
FÜR EINSATZBEREICHE VON -40°C BIS ZU 200°C  
SPRĘŻYNY GAZOWE DO ZAKRESU TEMPERATUR OD -40 DO +200°C

**EXTENSION SPEEDS FROM 0.05 - 0.3M/S**  
AUSSCHUBGESCHWINDIGKEITEN VON 0,05 - 0,3M/S  
PRĘDKOŚĆ WYSŁWU TĘD CZYSKA 0,05-0,3M/S



**PROGRESSION/FORCE INCREASE OF 10 - 400%**  
PROGRESSION/KRAFTANSTIEG VON 10 - 400%  
PROGRESJA/ZWIĘKSZENIE SIŁY O 10-400%

**GREASE CHAMBER AND SPECIAL LUBRICATION FOR NON-STANDARD INSTALLATION POSITIONS**

MIT FETTKAMMER UND SPEZIALSCHMIERUNG FÜR SCHWIERIGE EINBAULAGEN  
SPRĘŻYNY GAZOWE Z DODATKOWĄ KOMORĄ ZAPEWNIĄJĄCĄ OPTYMALNE SMAROWANIE  
DLA NIESTANDARDOWYCH POZYCJI MONTAŻU

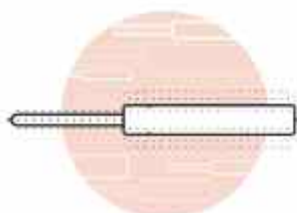

**NON-STANDARD COMBINATIONS OF PISTON ROD AND CYLINDER DIAMETERS  
TO REALIZE SPECIAL CHARACTERISTICS/FUNCTIONS**

KOMBINATIONSMÖGLICHKEITEN ZWISCHEN KOLBENSTANGEN- UND ZYLINDER-DURCHMESSER  
ZUR REALISIERUNG BESONDERER FUNKTIONEN  
NIESTANDARDOWE KOMBINACJE ŚREDNIC CYLINDRA I TĘD CZYSKA DLA OŚNIĄNIĘCIA FUNKCJI SPECJALNYCH



**DESIGN OF DYNAMIC DAMPING FOR PRECISE KINEMATIC ADJUSTMENT**  
AUSLEGUNG DER DYNAMISCHEN DÄMPFUNG ZUR GENAUEN KINEMATISCHEN ABSTIMMUNG  
ZASTOSOWANIE TŁUMIENIA DYNAMICZNEGO DLA PRECYZYJNEJ REGULACJI KINEMATYCZNEJ

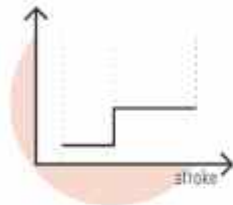
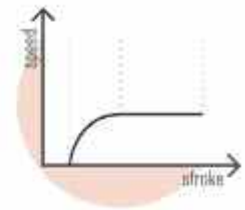

**APPLICATION OF COIL SPRINGS TO MODIFY FORCE HYSTERESIS IN DIFFERENT STROKE RANGES**  
KOMBINATION MIT DRÜCKFEDERN ZUR REALISIERUNG BESONDERER KRAFT-HYSTERESE IN HUBBEREICHEN  
ZASTOSOWANIE SPRĘŻYN MECHANICZNYCH DLA OSIĄGNIĘCIA ODPOWIEDNIEJ CHARAKTERYSTYKI SIŁ PRZY RÓŻNYCH ZAKRESACH SKOKU

**SEPARATING PISTON FOR SPECIAL REQUIREMENTS OPERATING CHARACTERISTICS**  
TRENNKOLBEN FÜR BESONDERE ANFORDERUNGEN AN DIE LAUFEIGENSCHAFT  
TŁOK ODZIELAJĄCY ZASTOSOWANY DLA SZCZEGÓLNYCH WYMAGAŃ DOTYCZĄCYCH CHARAKTERYSTYKI PRACY

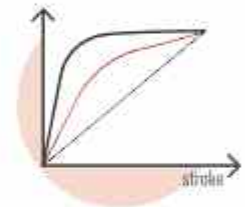

**APPLICATION OF PROTECTION TUBES AND DUST CAPS**  
KOMBINATION MIT SCHLITZRÖHREN UND SCHMUTZABSTREIFERN  
STOSOWANIE TŁUB I KŁEPAKÓW OCHRONNYCH

**SPECIALS OILS – FOOD AND ENVIRONMENTALLY COMPATIBLE**  
BESONDERS UMWELT- UND LEBENSMITTELVERTRÄGLICHE ÖLE  
STOSOWANIE OLEI, KTÓRE NIE SĄ SZKODLIWE DLA ŚRODOWISKA NATURALNEGO ORAZ SĄ ODPOWIEDNIE DO ŻYWNOSCI



**PAINTING AVAILABLE IN DIFFERENT COLOURS**  
LACKIERUNG IN VERSCHIEDENEN FARBEN VERFÜGBAR  
MOŻLIWE MALOWANIE W RÓŻNYCH KOLORACH

**CUSTOMIZED MARKINGS WITH PRIVATE LOGO AVAILABLE**  
SIGNIERUNG MIT EIGENEM KUNDENLOGO MÖGLICH  
MOŻLIWE OZNACZANIE WYROBU WŁASNYM LOGO KLIENTA





# IV.

## **FA-BLOCK GAS SPRINGS**

**FA-BLOCK** lockable gas springs deliver smooth continuous adjustment, desired positioning, and comfortable load stabilization. **FA-BLOCK** will assist you in moving heavy loads and lock them in a desirable position. Whether your requirement is for rigid locking or smooth cushioning around a set position, **FA-BLOCK** gas springs will meet numerous application requirements.

DE

### **FA-BLOCK BLOCKIERBARE-GASFEDERN**

**FA-BLOCK** blockierbare Gasfedern sorgen für stufenlose Verstellung, optimale Positionierung und komfortable Laststabilisierung. **FA-BLOCK** unterstützt beim Bewegen schwerer Lasten und arretiert diese in der gewünschten Position. Ob starre Blockierung oder sanfte Dämpfung um eine eingestellte Position-  
**FA-BLOCK** Gasfedern erfüllen unzählige Einsatzanforderungen.

PL

### **SPRĘŻYNY BLOKOWANE FA-BLOCK**

Sprężyny blokowane **FA-BLOCK** płynnie regulują pracę urządzeń. Z pomocą tego typu sprężyn z łatwością osiąga się żądane położenie i utrzymuje ciężar w równowadze. Sprężyny **FA-BLOCK** będą pomocne zawsze, gdy konieczne jest podniesienie ciężkiego elementu i zatrzymanie go w żądanym położeniu. Jakikolwiek są oczekiwania – czy zupełnej blokady czy płynnej amortyzacji wokół określonego punktu położenia-sprężyna **FA-BLOCK** je spełni.



**FA-BLOCK** GAS SPRINGS / GASDRUCKFEDERN / SPRĘŻYNY GAZOWE

# 10/22

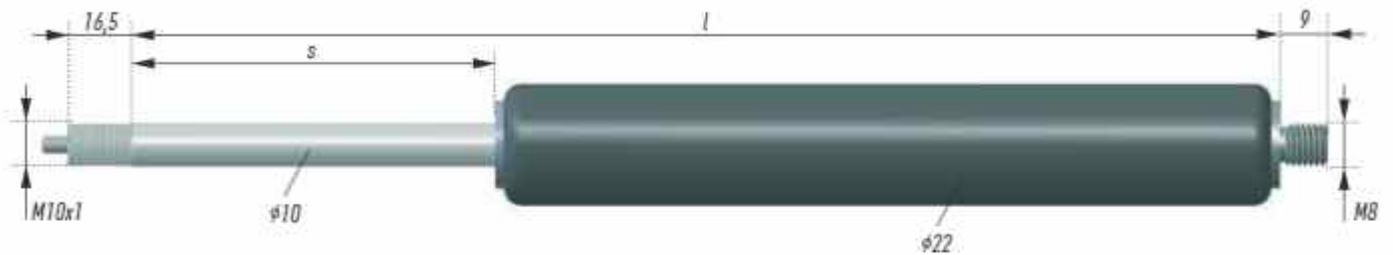

AVAILABLE EXT. FORCE: 40 N - 1000 N / VERFÜGBARE AUSSCHUBKRAFT: 40 N - 1000 N / ZAKRES SIŁ PRZY WYSUWIE TŁOCZYSKA: 50 N - 1200 N

BLOCKING TYPE	INSTALLATION DIRECTION	RELEASE STROKE (MM)	BLOCKING FORCE	S STROKE (MM)	INSTALLATION LENGTH (MM)	EXT. FORCE F1 (N)	ORDER NO.
 FLEXIBLE			FLEXIBLE	25	122	1000	4330001
				50	172		4330002
				75	222		4330003
				100	272		4330004
				125	322		4330005
				150	372		4330006
				175	422		4330007
				200	472		4330008
				250	572		4330009
				300	672		4330010
 RIGID IN PULLING DIRECTION	ANY	>2,5	PULL: MAX. 6000N PUSH: F1 X 3,5	25	136	1000	4331001
				50	200		4331002
				75	264		4331003
				100	327		4331004
				125	391		4331005
				150	455		4331006
				175	518		4331007
				200	582		4331008
				250	710		4331009
				300	837		4331010
 RIGID IN PUSHING DIRECTION			PUSH: MAX. 6000N PULL: F1 X 2,5	25	158	1000	4332001
				50	236		4332002
				75	315		4332003
				100	394		4332004
				125	473		4332005
				150	552		4332006
				175	630		4332007
				200	709		4332008

I / N: For further gas spring solutions tailored to your application, please contact us. Progression: flexible: 40% / rigid on tension and compression: 50%.  
 A wide range of mountings for the cylinder can be found on page 32/33.  
 (I) / Weitere auf Ihre Anwendung abgestimmte Gasfedern bieten wir Ihnen gerne an. Progression: flexibel: 40% / starre Blockierung auf Zug und Druck: 50%.  
 Eine breite Auswahl an passenden Anschlussstellen am Zylinder finden Sie auf Seite 32/33.  
 (N) / W celu uzyskania informacji dotyczących sprężyn gazowych dopasowanych do konkretnego zastosowania - prosimy o kontakt.  
 Progresa: elastyczna: 40% / sztywna przy ściskaniu i wysuwaniu tłoczyska: 50%. Szeroki zakres mocowań od strony cylindra można znaleźć na stronach 32/33.



**FA-BLOCK** GAS SPRINGS / GASDRUCKFEDERN / SPRĘŻYNY GAZOWE

# 10/28

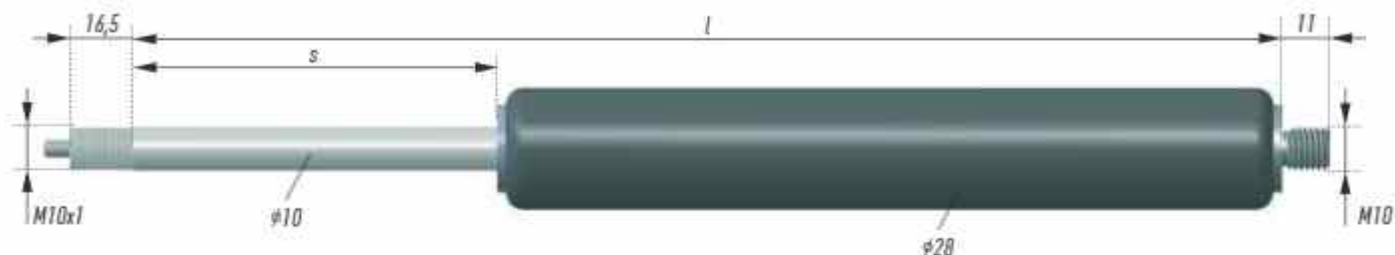

AVAILABLE EXT.FORCE : 50 N - 1200 N / VERFÜGBARE AUSSCHUBKRAFT: 50 N - 1200 N / ZAKRES SIŁ PRZY WYSUWIE TŁOCZYSKA: 50 N - 1200 N

BLOCKING TYPE	INSTALLATION DIRECTION	RELEASE STROKE (MM)	BLOCKING FORCE	s STROKE (MM)	l INSTALLATION LENGTH (MM)	EXT. FORCE F1 (N)	ORDER NO.
 FLEXIBLE	 ANY	 >2,5	 FLEXIBLE	50	178	 1200	4340001
				75	228		4340002
				100	278		4340003
				125	328		4340004
				150	378		4340005
				175	428		4340006
				200	478		4340007
				250	578		4340008
				300	678		4340009
350	778	4340010					
400	878	4340011					
 RIGID IN PULLING DIRECTION	 ANY	 >2,5	 PULL: MAX. 8000N PULL: F1 X 5,5	50	198		4341001
				75	256		4341002
				100	315		4341003
				125	374		4341004
				150	433		4341005
				175	491		4341006
				200	550		4341007
				250	668	4341008	
 RIGID IN PUSHING DIRECTION	 ANY	 >2,5	 PUSH: MAX. 8000N PULL: F1 X 4,5	300	785	4341009	
				350	903	4341010	
				50	216	4342001	
				75	281	4342002	
				100	347	4342003	
				125	413	4342004	
				150	479	4342005	
				175	544	4342006	
200	610	4342007					
250	742	4342008					

I/N: For further gas spring solutions tailored to your application, please contact us. Progression: flexible: 40% / rigid on tension and compression: 50%

A wide range of mountings for the cylinder can be found on page 36/37

III: Weitere auf Ihre Anwendung abgestimmte Gasfedern bieten wir Ihnen gerne an. Progression: flexibel: 40% / starre Blockierung auf Zug und Druck: 50%

Eine breite Auswahl an passenden Anschlussstellen am Zylinder finden Sie auf Seite 36/37

II: W celu uzyskania informacji dotyczących sprężyn gazowych dopasowanych do konkretnego zastosowania - prosimy o kontakt

Progressja: elastyczna: 40% / sztywna przy ściskaniu i wysuwie tłoczyska: 50%. Szeroki zakres mocowań od strony cylindra można znaleźć na stronach 36/37



# V. **FA-TRAC GAS SPRINGS**

**FA-TRAC** traction (pulling) gas springs operate in reverse function, where force generated by compressed gas is pulling a piston rod into a cylinder.

**FA-TRAC** traction gas springs deliver a technically superior and economically effective complete solution where pushing gas springs can only be used with complicated and partly ineffective force transmission. Robust design, high quality materials and a rigorous production process combine to ensure long lasting and reliable performance of **FA-TRAC** gas springs.

DE

## **FA-TRAC ZUGGASFEDERN**

**FA-TRAC** Zuggasfedern arbeiten in umgekehrter Funktionsweise, wobei die durch den Gasdruck erzeugte Kraft die Kolbenstange in den Zylinder zieht. **FA-TRAC** Traktionsgasfedern liefern technisch überlegene und wirtschaftliche Komplettlösungen, wo Standardgasfedern nur mit komplizierter und teilweise ineffektiver Kraftübertragung eingesetzt werden können.

Robustes Design, hochwertige Materialien und ein kompromissloser Produktionsprozess garantieren eine langlebige und zuverlässige Qualität der **FA-TRAC** Gasfedern.

PL

## **CIĄGNĄCE SPRĘŻYNY GAZOWE FA-TRAC**

Sprężyny gazowe **FA-TRAC** pracują odwrotnie niż standardowe sprężyny pchające. Siła powstała przy kompresji gazu wciąga tłoczysko do wnętrza cylindra. Sprężyny **FA-TRAC** dostarczają rozwiązanie technicznie doskonałe ekonomicznie, efektywne i kompletne, dla którego w potencjalnie zastosowanych standardowych sprężynach gazowych przenoszenie siły mogłoby się okazać zbyt skomplikowane i częściowo nieskuteczne. Łączymy solidność konstrukcji, wysokiej jakości materiały i rygorystyczny proces produkcji, aby zapewnić długotrwałość i niezawodność sprężyn gazowych **FA-TRAC**.

# FA-TRAC TRACTION GAS SPRINGS / GASZUGFEDERN / CIĄGNAĆE SPRĘŻYNY GAZOWE



## TRACTION GAS SPRING 6/19 / GASZUGFEDER 6/19 / CIĄGNAĆE SPRĘŻYNY GAZOWE 6/19

AVAILABLE PULLING FORCE: 20 N - 500 N / VERFÜGBARE ZUCKRÄFTE: 20 N - 500 N / ZAKRES SIŁ: 20 N - 500 N

 DIAMETER PISTON ROD (MM)	 DIAMETER CYLINDER (MM)	 THREAD PISTON ROD (MM)	 THREAD CYLINDER (MM)	 s STROKE (MM)	 l CONTRACTED LENGTH (MM)	 F <sub>1</sub> TRACTION FORCE F <sub>1</sub> (N)	 ORDER NO.
6	19	M6 x 8	M6 x 8	25	85	400	6120001
				50	110	400	6120002
				75	135	400	6120003
				100	160	400	6120004
				125	185	400	6120005
				150	210	400	6120006
				200	260	400	6120007
				250	310	400	6120008

1 N For further gas spring solutions tailored to your application, please contact us. A wide range of mountings can be found on page 27/28

1) Weitere auf Ihre Anwendung abgestimmte Gasfedern bieten wir Ihnen gerne an. Eine breite Auswahl an passenden Anschlussstellen finden Sie auf Seite 27/28

1) W celu uzyskania informacji dotyczących sprężyn gazowych dopasowanych do konkretnego zastosowania, prosimy o kontakt. Szeroki zakres mocowań znajduje się na stronach 27/28

## TRACTION GAS SPRING 8/22 / GASZUGFEDER 8/22 / CIĄGNAĆE SPRĘŻYNY GAZOWE 8/22

AVAILABLE PULLING FORCE: 30 N - 1000 N / VERFÜGBARE ZUCKRÄFTE: 30 N - 1000 N / ZAKRES SIŁ: 30 N - 1000 N

 DIAMETER PISTON ROD (MM)	 DIAMETER CYLINDER (MM)	 THREAD PISTON ROD (MM)	 THREAD CYLINDER (MM)	 s STROKE (MM)	 l CONTRACTED LENGTH (MM)	 F <sub>1</sub> TRACTION FORCE F <sub>1</sub> (N)	 ORDER NO.
8	22	M8 x 10	M8 x 10	50	120	1000	6230001
				75	145	1000	6230002
				100	170	1000	6230003
				125	195	1000	6230004
				150	220	1000	6230005
				175	245	1000	6230006
				200	270	1000	6230007
				250	320	1000	6230008
				300	370	1000	6230009

1 N For further gas spring solutions tailored to your application, please contact us. A wide range of mountings can be found on page 32/33

1) Weitere auf Ihre Anwendung abgestimmte Gasfedern bieten wir Ihnen gerne an. Eine breite Auswahl an passenden Anschlussstellen finden Sie auf Seite 32/33

1) W celu uzyskania informacji dotyczących sprężyn gazowych dopasowanych do konkretnego zastosowania, prosimy o kontakt. Szeroki zakres mocowań znajduje się na stronach 32/33



## FA-TRAC TRACTION GAS SPRINGS / GASZUGFEDERN / CIĄGNAĆE SPRĘŻYNY GAZOWE



### TRACTION GAS SPRING 10/28 / GASZUGFEDER 10/28 / CIĄGNAĆE SPRĘŻYNY GAZOWE 10/28

AVAILABLE PULLING FORCE: 50 N - 1500 N / VERFÜGBARE ZUGKRÄFTE: 50 N - 1500 N / ZAKRES SIŁ: 50 N - 1500 N

							
DIAMETER PISTON ROD (MM)	DIAMETER CYLINDER (MM)	THREAD PISTON ROD (MM)	THREAD CYLINDER (MM)	s STROKE (MM)	l CONTRACTED LENGTH (MM)	TRACTION FORCE F1 (N)	ORDER NO.
<b>10</b>	<b>28</b>	<b>M10x11</b>	<b>M10x11</b>	50	130	1500	6340001
				75	155	1500	6340002
				100	180	1500	6340003
				125	205	1500	6340004
				150	230	1500	6340005
				175	255	1500	6340006
				200	280	1500	6340007
				250	330	1500	6340008
				300	380	1500	6340009
				350	430	1500	6340010
			400	480	1500	6340011	

I N For further gas spring solutions tailored to your application, please contact us. A wide range of mountings can be found on page 36/37

III Weitere auf Ihre Anwendung abgestimmte Gasfedern bieten wir Ihnen gerne an. Eine breite Auswahl an passenden Anschlussteilen finden Sie auf Seite 36/37

IV W celu uzyskania informacji dotyczących sprężyn gazowych dopasowanych do konkretnego zastosowania, prosimy o kontakt. Szeroki zakres mocowań znajduje się na stronach 36/37

### TRACTION GAS SPRING 14/40 / GASZUGFEDER 14/40 / CIĄGNAĆE SPRĘŻYNY GAZOWE 14/40

AVAILABLE PULLING FORCE: 100 N - 4000 N / VERFÜGBARE ZUGKRÄFTE: 100 N - 4000 N / ZAKRES SIŁ: 100 N - 4000 N

							
DIAMETER PISTON ROD (MM)	DIAMETER CYLINDER (MM)	THREAD PISTON ROD (MM)	THREAD CYLINDER (MM)	s STROKE (MM)	l CONTRACTED LENGTH (MM)	TRACTION FORCE F1 (N)	ORDER NO.
<b>14</b>	<b>40</b>	<b>M14x1,5x15</b>	<b>M14x1,5x15</b>	100	195	4000	6450001
				125	220	4000	6450002
				150	245	4000	6450003
				175	270	4000	6450004
				200	295	4000	6450005
				225	320	4000	6450006
				250	345	4000	6450007
				300	395	4000	6450008
				350	455	4000	6450009
				400	495	4000	6450010

I N For further gas spring solutions tailored to your application, please contact us. A wide range of mountings can be found on page 39

III Weitere auf Ihre Anwendung abgestimmte Gasfedern bieten wir Ihnen gerne an. Eine breite Auswahl an passenden Anschlussteilen finden Sie auf Seite 39

IV W celu uzyskania informacji dotyczących sprężyn gazowych dopasowanych do konkretnego zastosowania, prosimy o kontakt. Szeroki zakres mocowań znajduje się na stronach 39



# VI.

# FA-INOX GAS SPRINGS + MOUNTINGS

**FA-INOX** stainless steel gas springs provide excellent resistance in demanding environmental conditions. The stainless steel materials used in production ensure excellent protection against humidity and corrosive compounds.

**FA-INOX** gas springs are standard for applications in the food industry, medical devices and countless other industrial and consumer areas where excellent corrosion resistance, refined appearance or magnetically neutral properties are desirable.

DE

## FA-INOX EDELSTAHLGASFEDERN

**FA-INOX**-Edelstahlgasfedern bieten eine hervorragende Beständigkeit bei anspruchsvollen Umgebungsbedingungen. Die in der Produktion verwendeten Edelstähle gewährleisten einen zuverlässigen Korrosionsschutz gegen Feuchtigkeit und korrosive Einflüsse.

**FA-INOX**-Gasfedern sind der Standard für Anwendungen in der Lebensmittelindustrie, Medizintechnik und zahlreichen anderen Industrie- und Anwendungsbereichen, in denen exzellente Korrosionsbeständigkeit, edle Optik sowie weitgehend unmagnetische Eigenschaften benötigt werden.

PL

## SPRĘŻYNY ZE STALI NIERDZEWNEJ FA-INOX

Sprężyny gazowe **FA-INOX** cechuje doskonała odporność na szkodliwe czynniki środowiska. Użycie do produkcji materiałów ze stali nierdzewnej zapewnia odporność wyrobu w atmosferze o wysokiej wilgotności i w obecności czynników powodujących korozję.

**FA-INOX** to doskonała propozycja dla urządzeń do przechowywania i przetwarzania żywności, wyposażenia medycznego i wszelkich urządzeń instalowanych na zewnątrz - czyli wszędzie tam, gdzie pożądane są właściwości antykorozyjne i antymagnetyczne stali nierdzewnej.



# FA-INOX GAS SPRINGS / GASDRUCKFEDERN / SPRĘŻYNY GAZOWE

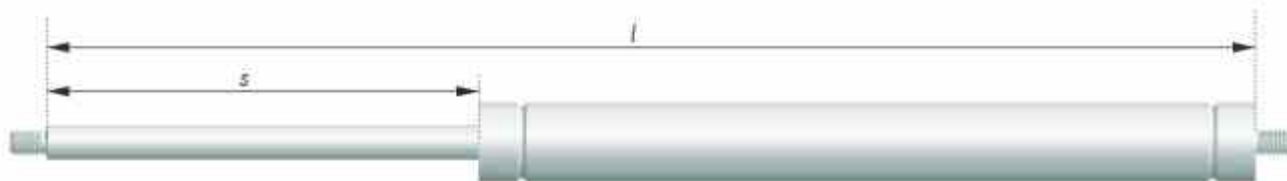

## STAINLESS GAS SPRING 8/19

EXT.FORCE: 50 N - 700 N / AUSSCHUBKRAFT: 50 N - 700 N / SIŁY PRZY WYSUWIE TŁOCZYSKA: 50 N - 700 N

THREAD PISTON ROD	THREAD CYLINDER	s STROKE	l EXTENDED LENGTH	EXT. FORCE F <sub>l</sub>	ORDER NO.
M8 (x9,0)	M8 (x8,0)	50	145	700	7220001
		75	195		7220002
		100	245		7220003
		125	295		7220004
		150	345		7220005
		175	395		7220006
		200	445		7220007
		225	495		7220008
		250	545		7220009
		300	645		7220010

## STAINLESS GAS SPRING 10/23

EXT.FORCE: 100 N - 1000 N / AUSSCHUBKRAFT: 100 N - 1000 N / SIŁY PRZY WYSUWIE TŁOCZYSKA: 100 N - 1000 N

M8 (x9,0)	M8 (x8,0)	75	195	1000	7330001
		100	245		7330002
		125	295		7330003
		150	345		7330004
		175	395		7330005
		200	445		7330006
		250	545		7330007
		300	645		7330008
		350	745		7330009
		400	845		7330010

## STAINLESS GAS SPRING 14/28

EXT.FORCE: 100 N - 2000 N / AUSSCHUBKRAFT: 100 N - 2000 N / SIŁY PRZY WYSUWIE TŁOCZYSKA: 100 N - 2000 N

M10 (x10,5)	M10 (x10,0)	100	260	2000	7440001
		150	360		7440002
		200	460		7440003
		250	560		7440004
		275	610		7440005
		300	660		7440006
		350	760		7440007
		400	860		7440008
		450	960		7440009
		500	1060		7440010

! N For further gas spring solutions tailored to your application, please contact us.

!|l Weitere auf Ihre Anwendung abgestimmte Gasfedern bieten wir Ihnen gerne an.

!|l W celu uzyskania informacji dotyczących sprężyn gazowych dopasowanych do konkretnego zastosowania, prosimy o kontakt.



**FOR GAS SPRING 8/19 AND 10/23 / FÜR GASDRUCKFEDER 8/19 AND 10/23 / DLA SPRĘŻYN GAZOWYCH 8/19 I 10/23**
**EYELET / AUGE / UCHWYT OCZKOWY**

ORDER NO.	DIMENSIONS REGARDING SKETCH						SW	MATERIAL
	a	b	c	d	e	f		
0025642	8,1	20	10	MB	-	16	-	SX

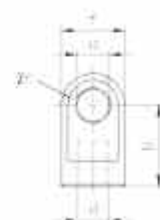
**CLEVIS WITH BOLT / GABELKOPF MIT BOLZEN / GŁOWICA WIDELKOWA ZE SWORZNIEM**

ORDER NO.	DIMENSIONS REGARDING SKETCH						SW	MATERIAL
	a	b	c	d	e	f		
0025643	8	32	8	MB	16	-	-	SX

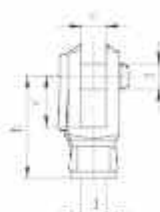
**ANGLE JOINT / WINKELGELENK / ŁĄCZE PRZEGUBOWE**

ORDER NO.	DIMENSIONS REGARDING SKETCH						SW	MATERIAL
	a	b	c	d	e	f		
0025643	MB	17	30	MB	13	12	11	SX

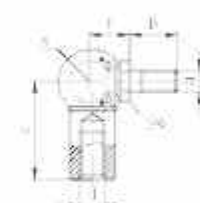
**FOR GAS SPRING 14/28 / FÜR GASDRUCKFEDER 14/28 / DLA SPRĘŻYN GAZOWYCH 14/28**
**EYELET / AUGE / UCHWYT OCZKOWY**

ORDER NO.	DIMENSIONS REGARDING SKETCH						SW	MATERIAL
	a	b	c	d	e	f		
0025645	8,1	20	12	M10	-	19	-	SX

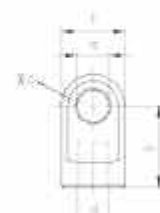
**CLEVIS WITH BOLT / GABELKOPF MIT BOLZEN / GŁOWICA WIDELKOWA ZE SWORZNIEM**

ORDER NO.	DIMENSIONS REGARDING SKETCH						SW	MATERIAL
	a	b	c	d	e	f		
0025644	10	40	10	M10	20	-	-	SX

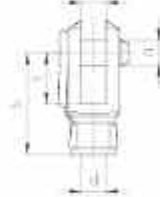
**ANGLE JOINT / WINKELGELENK / ŁĄCZE PRZEGUBOWE**

ORDER NO.	DIMENSIONS REGARDING SKETCH						SW	MATERIAL
	a	b	c	d	e	f		
0026564	M10	20	35	M10	16	16	13	SX

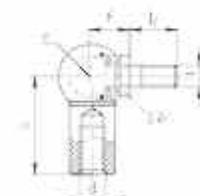
**ENG**

$\frac{Z}{X}$	material thickness
A	aluminium
SZ	steel zinc coated
SI	steel zinc iron coated
SX	stainless steel
P	plastic
Z	zinc die-cast zinc coated

**DE**

$\frac{Z}{X}$	Materialdicke
A	Aluminium
SZ	Stahl verzinkt
SI	Stahl zinkisenbeschichtet
SX	Edelstahl
P	Kunststoff
Z	Zinkdruckguss verzinkt

**PL**

$\frac{Z}{X}$	grubość materiału
A	aluminium
SZ	stal (biały ocynk)
SI	stal (czarny ocynk)
SX	stal nierdzewna
P	plastik
Z	odlew cynkalowy (biały ocynk)

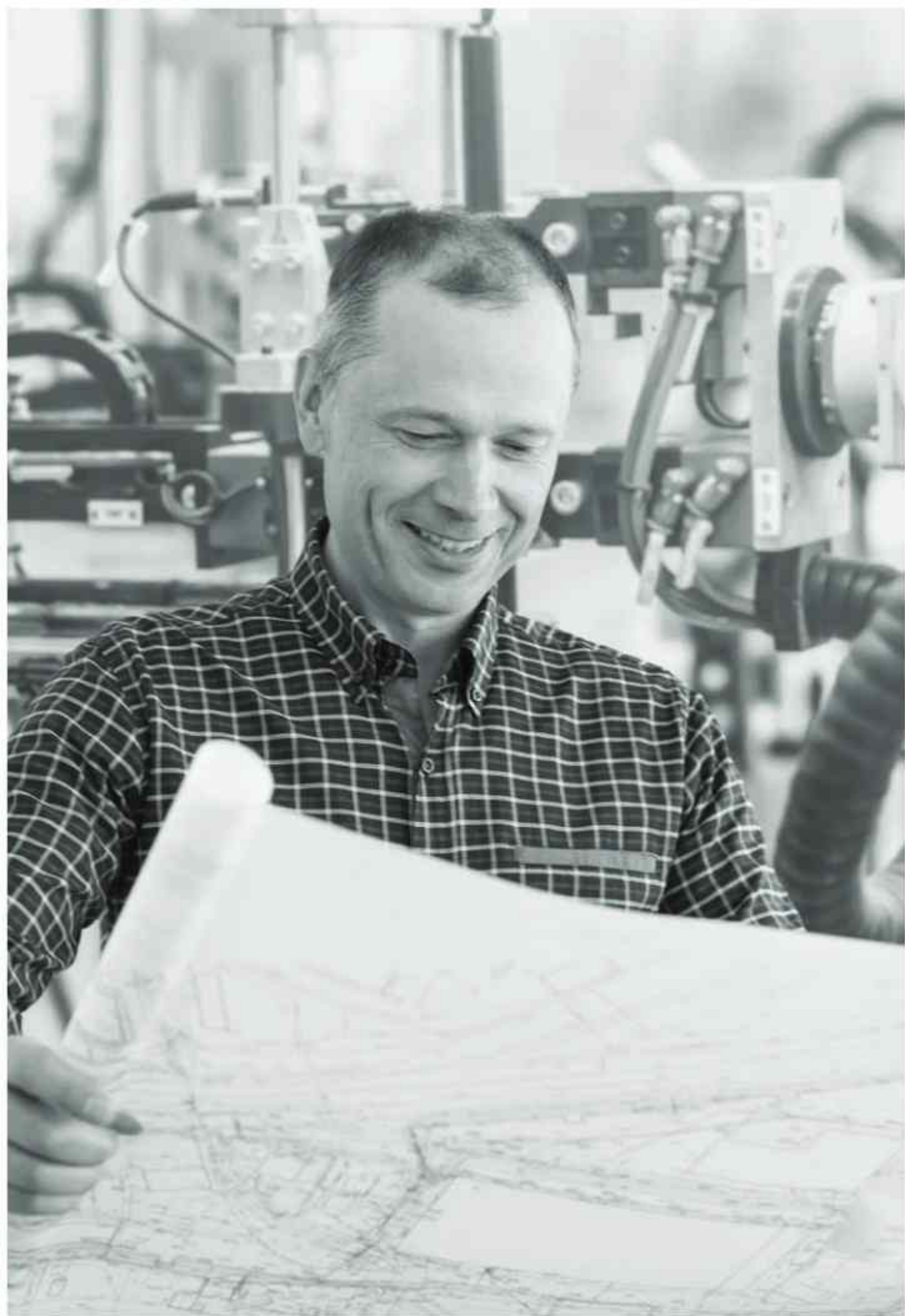

# VII.

# DAMPERS AND OIL BRAKES

**FA-ABS** dampers bring moving loads under control and counteract unwanted oscillations or vibrations effectively. The **FA-ABS** dampers and oil brakes are designed and manufactured according to the customer's specific kinematic requirements. Various mediums such as gas under pressure, hydraulic oils and mechanical springs are used to achieve the desired mode of action and the optimum end result.

DE

## FA-ABS DÄMPFER UND ÖLBREMSEN

**FA-ABS**-Dämpfer bringen bewegte Massen unter Kontrolle und wirken unerwünschten Schwingungen oder Vibrationen wirkungsvoll entgegen.

Dabei werden die **FA-ABS** Dämpfer und Ölbremse speziell nach den kinematischen Kundenforderungen ausgelegt und gefertigt. Verschiedene Medien wie Gasdruck, Hydrauliköl und mechanische Federn werden eingesetzt, um die gewünschte Wirkungsweise und das optimale Ergebnis zu erzielen.

PL

## TŁUMIKI I HAMULCE OLEJOWE FA-ABS

Tłumiki **FA-ABS**, w tym hamulce olejowe mają za zadanie kontrolować obciążenia i aktywnie przeciwdziałać niepożądanym oscylacjom lub drganiom. Tłumiki **FA-ABS** są projektowane zgodnie ze specyficznymi wymaganiami kinematycznymi określonymi przez klientów. Różne składniki, takie jak gaz pod ciśnieniem, olej i sprężyny mechaniczne są wykorzystywane do osiągnięcia pożądanego trybu działania i optymalnego efektu końcowego.



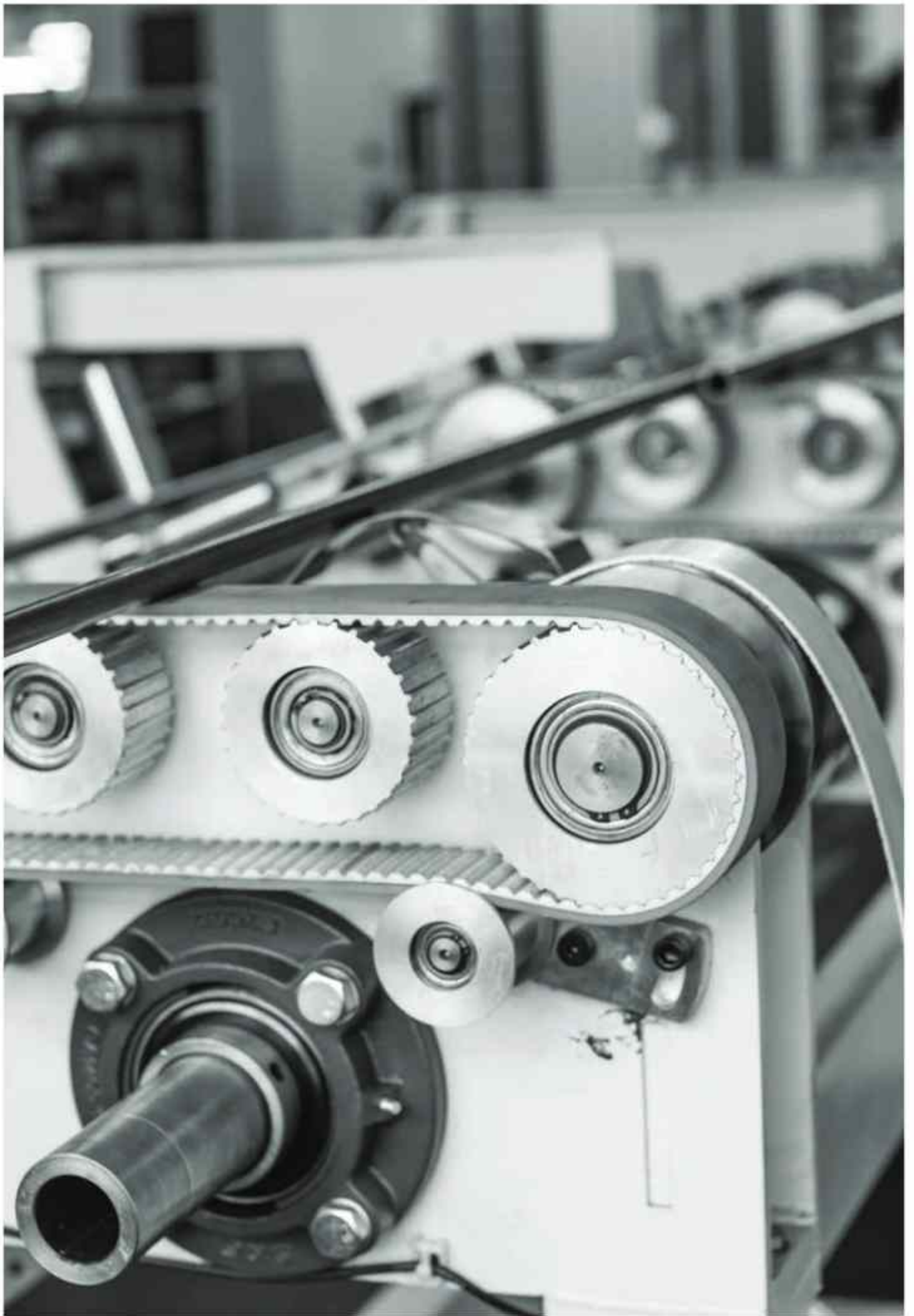



# FA-ABS DAMPERS AND OIL BRAKES / DÄMPFER UND ÖLBREMSEN / TŁUMIKI I HAMULCE OLEJOWE

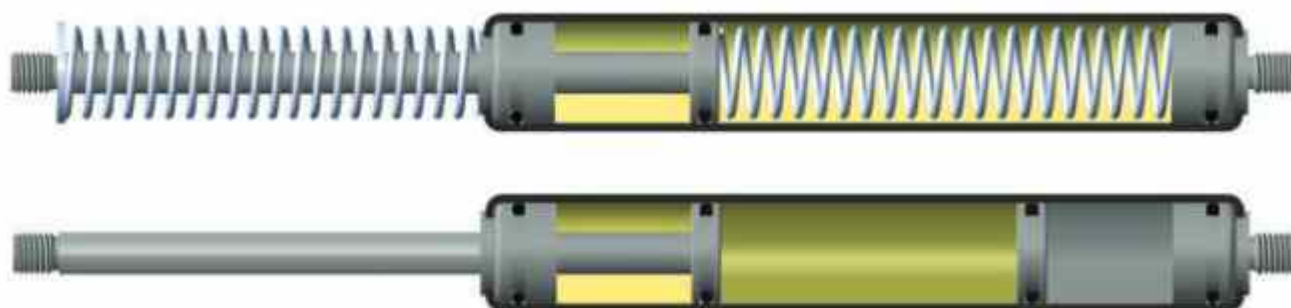

 TYPE	 DIAMETER PISTON ROD	 DIAMETER CYLINDER	 MAX. DAMPING FORCE	 STROKE	 FT EXT. FORCE	 ANY INSTALLING DIRECTION	 NO IDLE STROKE	 COMBINATION WITH COIL SPRINGS	
								 INTERNAL	 OUTSIDE ON PISTON ROD
HC 06/15	6	15	500N	50 - 200mm				X	X
HC-G 06/15	6	15	500N	50 - 200mm	X			X	X
HC-S 06/15	6	15	500N	50 - 200mm	X	X	X	X	X
HC 08/19	8	19	800N	50 - 300mm				X	X
HC-G 08/19	8	19	800N	50 - 300mm	X			X	X
HC-S 08/19	8	19	800N	50 - 300mm	X	X	X	X	X
HC 08/22	8	22	1000N	50 - 300mm				X	X
HC-G 08/22	8	22	1000N	50 - 300mm	X			X	X
HC-S 08/22	8	22	1000N	50 - 300mm	X	X	X	X	X
HC 10/22	10	22	1500N	75 - 400mm				X	X
HC-G 10/22	10	22	1500N	75 - 400mm	X			X	X
HC-S 10/22	10	22	1500N	75 - 400mm	X	X	X	X	X
HC 10/28	10	28	2000N	75 - 400mm				X	X
HC-G 10/28	10	28	2000N	75 - 400mm	X			X	X
HC-S 10/28	10	28	2000N	75 - 400mm	X	X	X	X	X
HC 10/40	10	40	2500N	75 - 400mm				X	X
HC-G 10/40	10	40	2500N	75 - 400mm	X			X	X
HC-S 10/40	10	40	2500N	75 - 400mm	X	X	X	X	X
HC 14/40	14	40	3000N	75 - 500mm				X	X
HC-G 14/40	14	40	3000N	75 - 500mm	X			X	X
HC-S 14/40	14	40	3000N	75 - 500mm	X	X	X	X	X
HC 20/40	20	40	5000N	100 - 600mm				X	X
HC-G 20/40	20	40	5000N	100 - 600mm	X			X	X
HC-S 20/40	20	40	5000N	100 - 600mm	X	X	X	X	X

ING

HC hydraulic control  
 HC-G hydraulic control with gas pressure  
 HC-S hydraulic control with separation piston

DE

HC hydraulisch reguliert  
 HC-G hydraulisch reguliert mit Gasdruck  
 HC-S hydraulisch reguliert mit Trennkolben

PL

HC tłumik hydrauliczny  
 HC-G tłumik hydrauliczny dopełniony gazem  
 HC-S tłumik hydrauliczny z tłokiem oddzielającym



# VIII. **ACCESSORIES**

**FA-ACCESSORIES** offer protection, additional functions, safety and a variety of mounting options for our products.

DE

---

## **ZUBEHÖR**

**FA-ACCESSORIES** bieten Schutz, zusätzliche Funktionen, Sicherheit sowie eine Vielzahl von Befestigungsmöglichkeiten für unsere Produkte.

PL

---

## **AKCESORIA**

**FA-AKCESORIA** zapewniają ochronę, bezpieczeństwo, dodatkowe funkcje, a także umożliwiają wiele opcji montażu naszych produktów.

## FA-ACCESSORIES

### BALL STUD / KUGELZAPFEN / SWORZEŃ KULOWY

ORDER NO.	DIMENSIONS REGARDING SKETCH							MATERIAL
	a	b	c	d	e	f	SW	
0025024	M6	13	-	-	10	12	13	SZ
0025037	M8	12	-	-	10	12	13	SZ
0025114	M8	13	-	-	10	17	13	SZ
0025117	M8	15	-	-	10	17	13	SZ
0025163	M8	18	-	-	10	17	13	SZ
0025247	M8	14	-	-	10	25	13	SZ
0025646	M8	16	-	-	13	13	11	SZ
0025647	M10	20	-	-	13	16	17	SZ

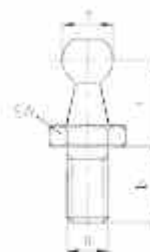

### NUT / MUTTER / NAKRĘTKA

ORDER NO.	DIMENSIONS REGARDING SKETCH							MATERIAL
	a	b	c	d	e	f	SW	
0048031	M6	5	-	-	-	-	10	SZ
0048032	M8	6,5	-	-	-	-	13	SZ
0048033	M10	8	-	-	-	-	17	SZ
0048034	M10x1	5	-	-	-	-	17	SZ

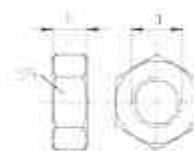

### CLEVIS PIN / LAGERBOLZEN / SWORZEŃ

ORDER NO.	DIMENSIONS REGARDING SKETCH							MATERIAL
	a	b	c	d	e	f	SW	
0025648	8	19	39	M8	-	12	14	SZ

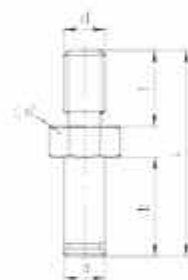

### SL RETAINER / SL SICHERUNGSClip / MOCOWANIE ZABEZPIEZAJĄCE

ORDER NO.	DIMENSIONS REGARDING SKETCH							MATERIAL
	a	b	c	d	e	f	SW	
0025649	8	-	14	18	-	-	-	SZ



### BEARING HINGE / LAGERSCHUH / ZAWIAS ŁOŻYSKOWY

ORDER NO.	DIMENSIONS REGARDING SKETCH							MATERIAL
	a	b	c	d	e	f	SW	
0025650	8	51	17	6,5	13	20	-	SZ
0025651	8	85	23	6,5	13	22,5	-	SZ

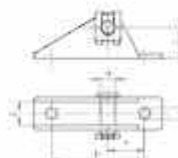

### ANGLE BRACKET / WINKELBESCHLAG / UCHWYT KĄTOWY

ORDER NO.	DIMENSIONS REGARDING SKETCH							MATERIAL
	a	b	c	d	e	f	h	
0025652	10	38	19	5,1	12,5	8	20	SZ

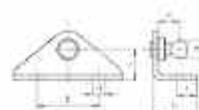



## FA-ACCESSORIES

### BRACKET / BESCHLAG / UCHWYT

ORDER NO.	DIMENSIONS REGARDING SKETCH							MATERIAL
	a	b	c	d	e	f	sw	
0025653	0	55	30	4,2	16	11	-	SZ

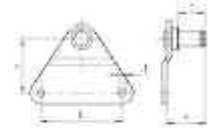

### BRACKET / BESCHLAG / UCHWYT

ORDER NO.	DIMENSIONS REGARDING SKETCH							MATERIAL
	a	b	c	d	e	f	sw	
0025654	10	55	30	4,2	17	-	-	SZ
0025655	13	55	30	4,2	17,5	-	-	SZ

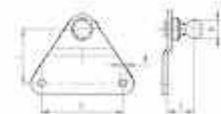

### LOCKING TUBE / ARRETIERROHR / TUBA BLOKUJĄCA

FOR GAS SPRINGS 6/19 / (DŁ. GASOWICKI ŁOŻY 6/19 / DŁA SPRĄŻYN GAZOWYCH 6/19 (10,5 MM STROKE REDUCTION / 10,5 MM REDUKCJA WZDROŻENIA / 10,5 MM - REDUKCJA ŚRODKU))

ORDER NO.	S STROKE	DIMENSIONS REGARDING SKETCH				MATERIAL
		a	b	c	d	
0026565	100	8	25	28	98	SZ+painted
0026566	125	8	25	28	123	SZ+painted
0026567	140	8	25	28	138	SZ+painted
0026568	160	8	25	28	158	SZ+painted
0026569	175	8	25	28	173	SZ+painted
0026570	200	8	25	28	198	SZ+painted
0026571	220	8	25	28	218	SZ+painted
0026572	250	8	25	28	248	SZ+painted
0026573	275	8	25	28	273	SZ+painted
0026574	300	8	25	28	298	SZ+painted
0026575	350	8	25	28	348	SZ+painted



### LOCKING STRUT / ARRETIERSTÜTZE / SZYNA BLOKUJĄCA

FOR GAS SPRINGS 10/22 AND 14/28 / (DŁ. GASOWICKI ŁOŻY 10/22 I 14/28 / DŁA SPRĄŻYN GAZOWYCH 10/22 I 14/28)

ORDER NO.	S STROKE	DIMENSIONS REGARDING SKETCH				MATERIAL
		a	b	c	d	
0025656	100	8,5	15	18,5	115	SZ
0025657	125	8,5	15	18,5	140	SZ
0025658	150	8,5	15	18,5	165	SZ
0025659	175	8,5	15	18,5	190	SZ
0025660	200	8,5	15	18,5	215	SZ
0025661	250	8,5	15	18,5	265	SZ
0025662	300	8,5	15	18,5	315	SZ
0025663	350	8,5	15	18,5	365	SZ
0025664	400	8,5	15	18,5	415	SZ
0025665	450	8,5	15	18,5	465	SZ
0025666	500	8,5	15	18,5	515	SZ



# FA-ACCESSORIES

## PROTECTION TUBE / SCHUTZROHR / TUBA OCHRONNA

FOR GAS SPRINGS 10/22 / FÖR GASDRUCKEDER 10/22 / DLA SPRĘŻYN GAZOWYCH 10/22 (10,5 MM STROKE REDUCTION / 10,5 MM HUBBILDERUNG / 10,5 MM - REDUKCJASKOKO)

ORDER NO.	S STROKE	DIMENSIONS REGARDING SKETCH				MATERIAL
		a	b	c	d	
0025667	100	9,5	23,5	26	125	P
0025668	125	9,5	23,5	26	150	P
0025669	150	9,5	23,5	26	175	P
0025670	160	9,5	23,5	26	185	P
0025671	175	9,5	23,5	26	200	P
0025672	200	9,5	23,5	26	225	P
0025673	250	9,5	23,5	26	275	P
0025674	300	9,5	23,5	26	325	P
0025675	350	9,5	23,5	26	375	P
0025676	390	9,5	23,5	26	415	P
0025677	450	9,5	23,5	26	475	P



## PROTECTION TUBE / SCHUTZROHR / TUBA OCHRONNA

FOR GAS SPRINGS 14/20 / FÖR GASDRUCKEDER 14/20 / DLA SPRĘŻYN GAZOWYCH 14/20 (10,5 MM STROKE REDUCTION / 10,5 MM HUBBILDERUNG / 10,5 MM - REDUKCJASKOKO)

ORDER NO.	S STROKE	DIMENSIONS REGARDING SKETCH				MATERIAL
		a	b	c	d	
0025678	100	12,5	29	32	130	P
0025679	150	12,5	29	32	180	P
0025680	200	12,5	29	32	230	P
0025681	250	12,5	29	32	280	P
0025682	275	12,5	29	32	305	P
0025683	300	12,5	29	32	330	P
0025684	325	12,5	29	32	355	P
0025685	350	12,5	29	32	380	P
0025686	375	12,5	29	32	405	P
0025687	395	12,5	29	32	425	P
0025688	450	12,5	29	32	480	P
0025689	500	12,5	29	32	530	P



## RELEASE HEAD / AUSLÖSEKOPF / GŁÓWICA ZWALNIAJĄCA

ORDER NO.	DIMENSIONS REGARDING SKETCH							MATERIAL
	a	b	c	d	e	f	sw	
0048029	8,1	30	11	M10x1	-	-	-	Z

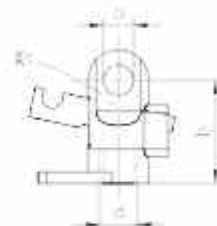

## RUBBER BUMPER AND WASHER / GUMMIPUFFER UND SCHEIBE / ZDERZAK GUMOWY / PODKŁADKA

ORDER NO.	DIMENSIONS REGARDING SKETCH							MATERIAL
	a	b	c	d	e	f	sw	
0048035	21	10,5	2	-	-	-	-	P
0048036	20	10,5	3	-	-	-	-	rubber / Gummi

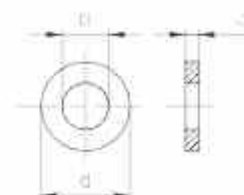

## FA-ACCESSORIES

### BOWDEN WIRE / BOWDENZUG / LINKA BOWDENA

 <b>ART. NO.</b>	 <b>\$ STROKE</b>
<b>0048028</b>	500
<b>0048027</b>	650
<b>0048030</b>	1000
<b>0048026</b>	1200

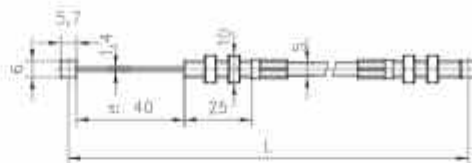

#### ENG

$\frac{\times}{\times}$	material thickness
A	aluminum
SZ	steel zinc coated
SI	steel zinc iron coated
SX	stainless steel
P	plastic
Z	zinc die-cast zinc coated

#### DE

$\frac{\times}{\times}$	Materialdicke
A	Aluminium
SZ	Stahl verzinkt
SI	Stahl zink-eisenbeschichtet
SX	Edelstahl
P	Kunststoff
Z	Zinkdruckguss verzinkt

#### PL

$\frac{\times}{\times}$	grubość materiału
A	aluminium
SZ	stal (biały ocynk)
SI	stal (czarny ocynk)
SX	stal nierdzewna
P	plastik
Z	odlew cynkowy (biały ocynk)

*I.N. The content and images in the catalogue are our exclusive property and are not allowed to be reproduced or used in any other way without our consent.  
Technical changes and optimizations reserved.*

*(II) Der Inhalt und die Bilder des Katalogs sind unser ausschließliches Eigentum und dürfen nicht ohne unsere Zustimmung vervielfältigt oder anderweitig verwendet werden.  
Technischen Änderungen und Optimierungen vorbehalten.*

*(N) Treści i obrazy w katalogu są wyłączną własnością FA Krosno i nie mogą być reproduktowane ani wykorzystywane w żaden sposób bez uzyskania odrębnej zgody.  
Zastrzeżenie się możliwość dokonywania zmian technicznych i optymalizacji w treści katalogu.*





**FA KROSNO SPÓŁKA AKCYJNA Sp. k.**  
UL. GEN. L. OKULICKIEGO 9  
38-400 KROSNO  
POLAND

TEL.: +48 13 437 10 00  
FAX: +48 13 437 10 07  
EMAIL: [FAKROSNO@FAKROSNO.PL](mailto:FAKROSNO@FAKROSNO.PL)  
[WWW.FAKROSNO.PL](http://WWW.FAKROSNO.PL)

**FA KROSNO GmbH**  
KIEFERWEG 14A  
54283 MERMUTH  
GERMANY

TEL.: +49 6745 182 499  
FAX: +49 6745 182 495  
EMAIL: [INFO@FAKROSNO.DE](mailto:INFO@FAKROSNO.DE)  
[WWW.FAKROSNO.DE](http://WWW.FAKROSNO.DE)