

# HS701 EXTRA HIGH-TIP DUMPER BED VERSION

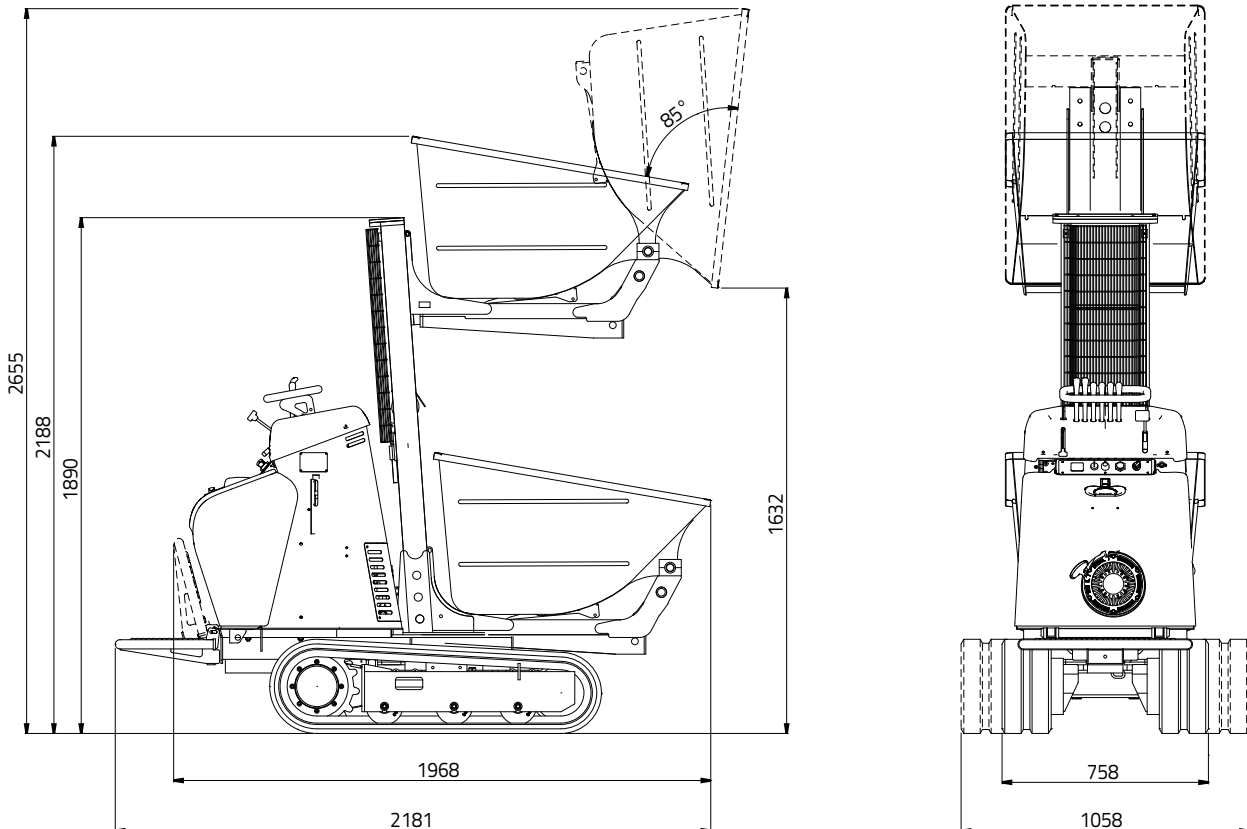

# HS701

## EXTRA HIGH-TIP DUMPER BED VERSION

### PETROL ENGINE

Brand and type.....	Honda GX270
Pistons and displacement .....	single-cylinder 270 cc
Max gross power .....	8,4 HP - 6,3 kW @ 3600 rpm
Starting.....	electric 12 volt
Fuel tank .....	5,3 liters
Granted noise level .....	Lwa 99 dB

### DIESEL ENGINE

Brand and type.....	KUBOTA OC 95
Pistons and displacement .....	single-cylinder 416 cc
Max gross power .....	9,4 HP - 7,0 kW @ 3600 rpm
Starting.....	electric 12 volt
Fuel tank .....	5,5 liters
Granted noise level .....	Lwa 101 dB

### DISTRIBUTOR

Type .....	mechanical
------------	------------

### HYDRAULIC PUMPS

Number and type .....	n° 3 gear pumps
-----------------------	-----------------

### TRACKS

Track tensioner.....	grease
Track width .....	180 mm
Rollers per side .....	3
Undercarriage width open/close .....	758 - 1058 mm

### PERFORMANCE

Translation speed .....	2,2 - 3,3 km/h
Max. inclination .....	15° (dumper bed lowered)
Capacity .....	550 kg

### DUMPER BED CAPACITY

Rated volume (ISO 6483) .....	0,29 m <sup>3</sup>
Struck volume .....	0,24 m <sup>3</sup>

### OPERATING WEIGHT (without operator)

Petrol engine .....	746 kg
Diesel engine .....	800 kg