

Fan coils

Cooling, heating and ventilation for a pleasant indoor air quality in all rooms

Genau
mein
Klima.

KAMPMANN

Contents

The air conditioning of buildings is becoming increasingly relevant. Typical products include fan coils, which, as water-based systems, are as current and useful as never before. In the height of summer, as in winter, but also in the shoulder seasons during which other systems reach their limits, fan coil systems guarantee a pleasant indoor air quality – tailored to individual preferences. Fan coil systems are capable of heating or cooling rooms when combined with a heat pump or chiller. Equipped with high-performance and efficient EC fans, fan coils react quickly to changing indoor air requirements. When used as a hybrid system, fan coils are also capable of supplying primary air and controlling the temperature of the ambient air.

The right product for every application. Whisper-quiet for use in hotels and offices, high-performance to provide the very best air quality in larger spaces, or including an integrated filter system for hygienically perfect room air. The use of fan coil systems guarantees a very personal and pleasant room climate.

5



Product overview

17

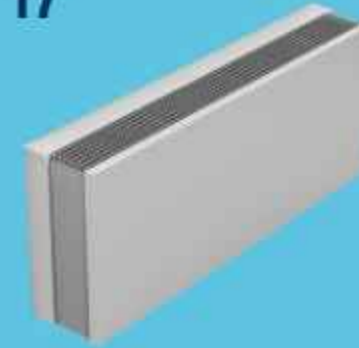

Venkon

19

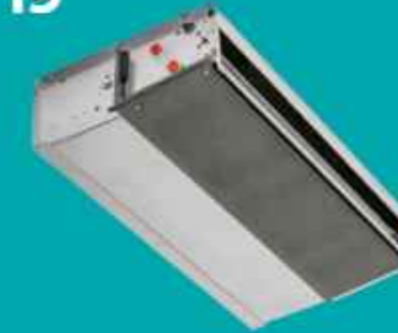

Venkon XL

21



KaDeck

23



Ultra

25



Ultra Allround

27



KaCool D AF

29



KaCool W

31

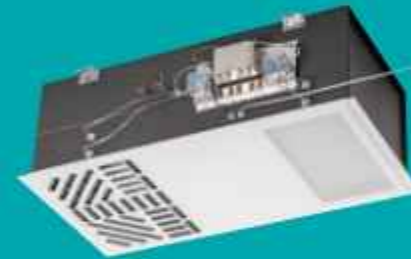

KaCool D HC

33



KaCool D HY

35



PowerKon LT

37

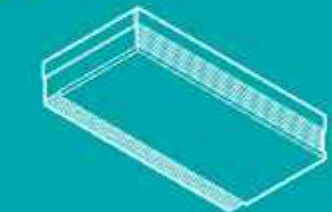

Variants and accessories

39



Heat Pump ready

43



Controls

47



Service

49



References

We are the market leader, thanks to our myriad options.

With over 1000 employees at 15 sites around the world, Kampmann is one of the major players in the construction and building services sector. **Kampmann systems for heating, cooling and ventilation are at the forefront of different market segments today.**

Genau mein Klima.

KAMPMANN



1000+

Kampmann Group employees

902

Fan coil product variants in the standard range alone



International sites



Headquarters
Kampmann GmbH & Co. KG
Lingen (Em), Germany



> Canada/USA
> France

> Italy
> Netherlands

> Austria
> Poland

> Switzerland
> Great Britain

		Heating	Supply air (optional)	Cooling	Filtering	Heat output in [KW]	Cooling output in [KW]	Air volume in [m³/h]
Venkon 	I would like to heat, cool and filter with maximum comfort.	✓	✓	✓	✓	6.6 – 26.6 ¹⁾	3.1 – 11.3 ²⁾	46 – 1713
Venkon XL 	I would like to heat, cool and filter with increased external pressure.	✓	✓	✓	✓	1.5 – 46.9 ¹⁾	0.7 – 16.9 ²⁾	110 – 2975
KaDeck 	I would like to flexibly cool and heat offices.	✓	✓	✓	✓	0.4 – 5.8 ¹⁾	0.3 – 3.0 ²⁾	39 – 415
Ultra 	I would like to heat, cool and ventilate high-end large spaces.	✓	✓	✓	✗	6.0 – 53.6 ¹⁾	1.4 – 14.0 ²⁾	590 – 5620
Ultra Allround 	I would like to heat, cool and ventilate high-end large spaces.	✓	✓	✓	✗	2.2 – 45.6 ¹⁾	1.4 – 16.8 ²⁾	430 – 4168

¹⁾ at LPHW 75/65°C, room temperature = 20°C | ²⁾ at CHW 7/12°C, room temperature = 27°C, 48% rel. humidity

		Heating	Supply air (optional)	Cooling	Filtering	Heat output in [KW]	Cooling output in [KW]	Air volume in [m³/h]
KaCool D AF 	I would like to heat, cool and ventilate with maximum comfort.	✓	✓	✓	✗	2.5 – 28.5 ¹⁾	1.8 – 12.1 ²⁾	270 – 1735
KaCool W 	I would like a design wall-mounted unit for heating and cooling.	✓	✗	✓	✗	3.8 – 9.7 ¹⁾	1.4 – 3.8 ²⁾	246 – 730
KaCool D HC 	I would like to heat, cool and filter certified to DIN 1946-4.	✓	✗	✓	✓	0.3 – 6.3 ¹⁾	3.1 – 2.9 ²⁾	19 – 489
KaCool D HY 	I would like to heat, cool and filter certified to VDI 6022.	✓	✗	✓	✓	1.1 – 11.5 ¹⁾	0.7 – 4.9 ²⁾	98 – 705
PowerKon LT 	I would like to heat and cool energy-efficiently with low water temperatures	✓	✗	✓	✗	0.31 – 2.87 ¹⁾	0.22 – 2.5 ²⁾	-

¹⁾ at LPHW 75/65°C, room temperature = 20°C | ²⁾ at CHW 7/12°C, room temperature = 27°C, 48% rel. humidity | ³⁾ at LPHW 46/40°C, room temperature = 20°C

Heat and cooling outputs

Flow / return temperature of 75/65 °C

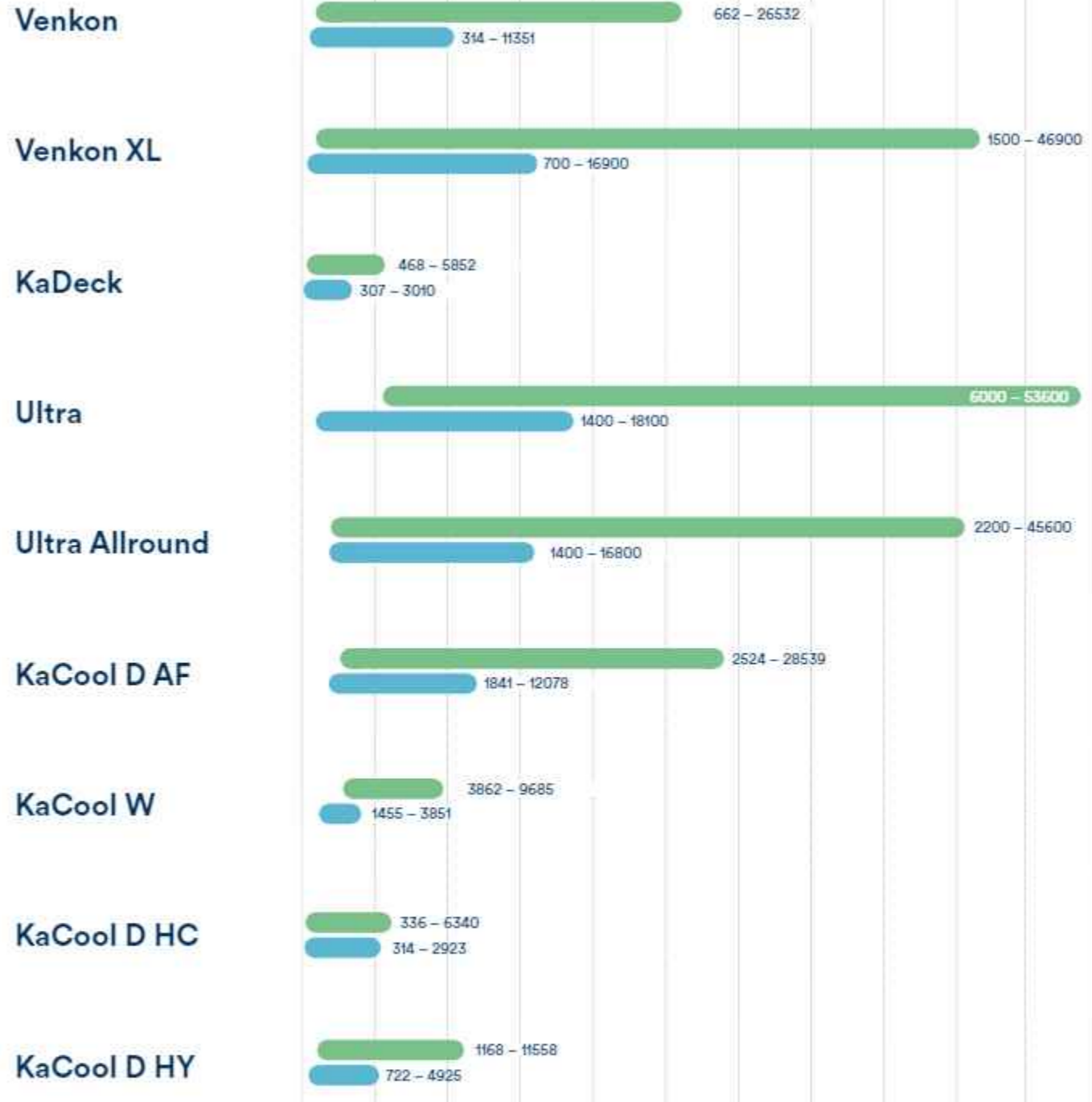

Flow / return temperature of 45/40 °C (low-temperature operation)

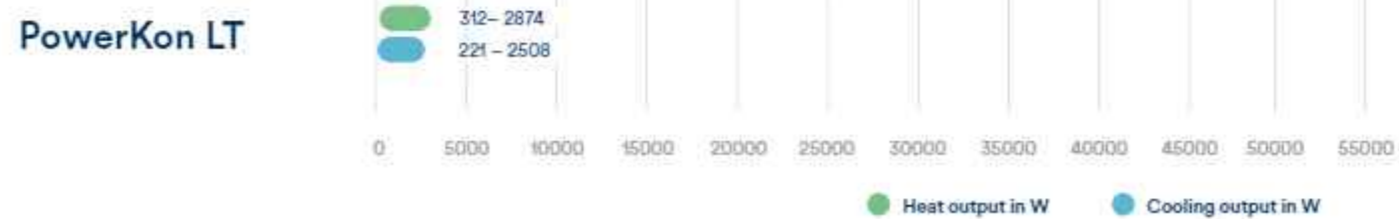

Installation options

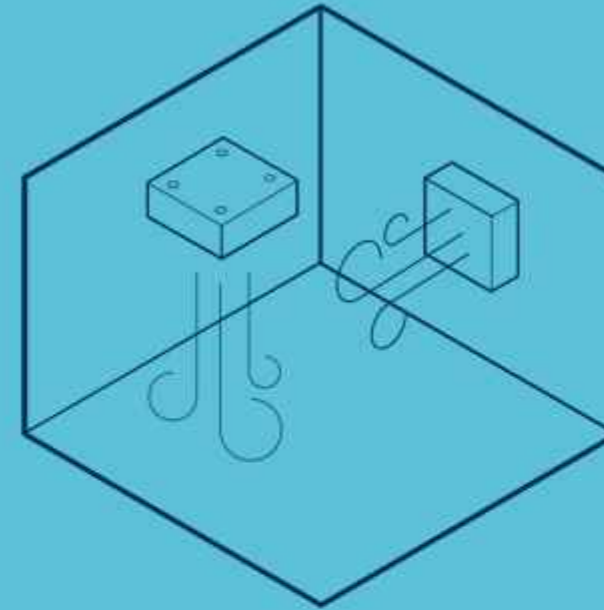

Wall-mounted

- Venkon
- KaCool W
- PowerKon LT

Ceiling-mounted

- Ultra
- Ultra Allround
- Venkon
- Venkon XL
- KaDeck
- KaCool D AF
- KaCool D HC
- KaCool D HY



Market-leading quiet



Venkon fan coils fulfil all expectations for a quiet environment, thanks to their energy-saving EC technology. Peace and quiet so that you can focus on important matters. Market-leading quiet and nonetheless outstanding outputs at higher fan speed ranges. Equipped with the KaControl room automation system, Venkons produce a very personal climate of well-being at any time and in any weather.



Individual use

Venkons adapt perfectly to any individual room situation. Thanks to their slimline design, Venkons are concealed almost invisibly within the suspended ceiling. Depending on the requirements, the connections can be arranged on the left or right of the product.

And with a wealth of model versions, Venkons are the right choice time after time. A wide range of sizes and housing designs are also available for installation below the suspended ceiling. In short: Venkons fit everywhere!



Diverse shapes and sizes

Venkon models with housing

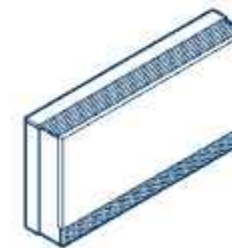

Wall-mounted
Front intake

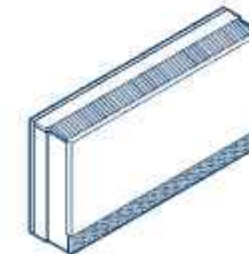

Free-standing
Front intake, with rear panel

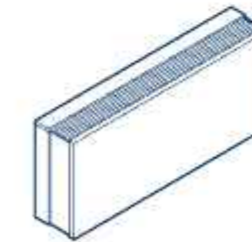

Wall-hanging
Intake on the underside

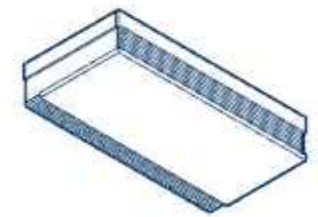

Ceiling
Intake on the underside

Fits every time

The Ultra is synonymous with efficient and fast-response air conditioning in supermarkets, shopping centres and other high-end large spaces. It can be recognised by its hexagonal casing. Fan coils for heating and cooling really come into their own during the shoulder months of spring and autumn. And it also makes sense to use water as the carrier medium: energy-efficient, safe and low-maintenance.



Clinically clean

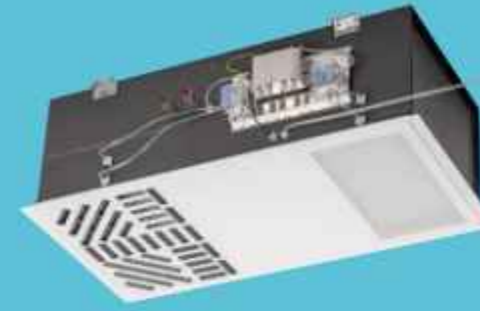

First-class filter quality and a flawless cleaning concept make the KaCool D HC the perfect equipment to fit in doctors' surgeries and clinics. It therefore complies with DIN 1946-4 for air handling units in healthcare buildings and premises, and accordingly is fitted with ePM1>55% and ePM1>85 % filters in the air intake and outlet. And, of course, it is certified to deliver a pleasant indoor climate in challenging environments too.



At your convenience

Ceiling cassettes are the traditional method of air conditioning office buildings, hotels, showrooms and shop floors. Apart from their high output, it is their draught-free air flow that sets them apart. The KaCool D AF is designed specifically for this. The air discharge makes maximum use of the Coanda effect. It produces an air stream from the ceiling that falls into the room at a seriously reduced speed. That's what we call AtmosFeel (AF).



Everything under control

KaDeck is the flexible solution for the air conditioning of offices in existing buildings and new buildings as well. Virtually invisible and space-saving, the KaDeck fits unobtrusively but powerfully into every room design. Continuously variable EC fans deliver ultra-quiet operation and the very best working conditions. All components are easily accessible and maintenance could not be simpler. The KaDeck remains hygienically clean throughout its entire service life.



The heat pump-based heater for the home

PowerKon LT

The myth that a heat pump in your own home only works with underfloor heating is long out of date. PowerKon LT heat pump-based heaters are the ideal choice, especially in homes – in existing and new houses.

The wall-mounted unit operates with low water temperatures and fully exploits the low flow temperatures of a heat pump: a 35 °C low temperature system with a PowerKon LT works around 25 – 35% more efficiently than a high-temperature system operating at 55 °C.

Equipped with an energy-saving EC tangential fan, the PowerKon LT operates very quietly and, thanks to its perfectly fitted EEP moulded parts, also optimises its air flow for outstanding efficiency and output. PowerKon LT units even offer a built-in cooling function, depending on the pipework network and individual comfort requirements.



Heating and cooling in low temperature mode

Ultra Allround

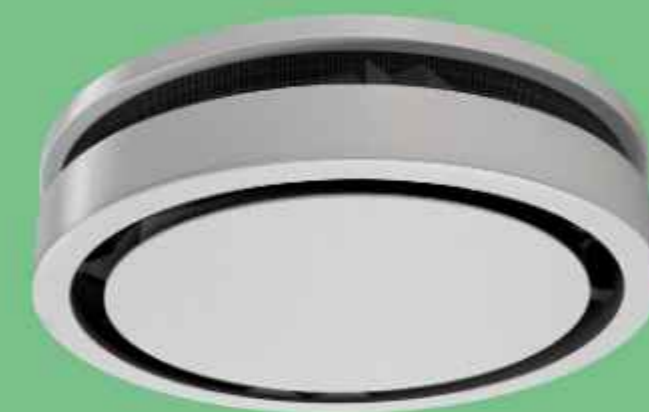

Developed as a high-quality design unit, the Ultra Allround is ideal for use with open ceiling concepts in public and industrial areas where it can be operated up to a ceiling height of 7 m. The circular encased housing is designed to discharge warm or cold air into the occupied zone, as required, creating a comfortable climate at all times. As the unit is designed for operation with low water temperatures, it can be operated in new buildings as well as in refurbished buildings equipped with a heat pump. Perfectly fitting EPP components enable the operator to maximise the benefits of the material: accurate air flow in the unit with a high level of air-tightness for maximum efficiency.

Venkon

Heating, cooling and filtering for maximum comfort.
Peak loads in summer and in the depths of winter.

Heating:
LPHW

Cooling:
CHW

Supply air in conjunction with a centralised ventilation system

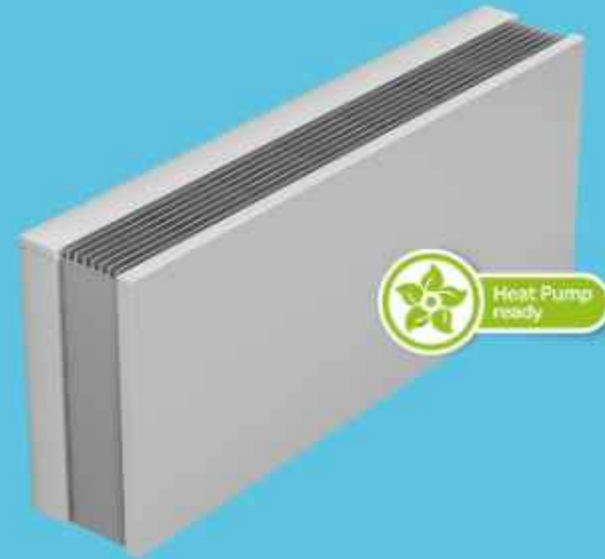

Calculate your product online:
kampmanngroup.com/products/fan-coils

Technical data

Filter design	Size	Height	Length	Depth	Heat output ¹	Cooling output ²			
						2-pipe		4-pipe	
						[W]	[m ³ /h]	[W]	[m ³ /h]
		C	A	B					
		[mm]	[mm]	[mm]					
Filter ISO Coarse (G0)	61	605	900	235	2100 - 8332	885 - 3567	1646 - 5179	849 - 3355	
	63		1200		3042 - 12885	1232 - 5206	2455 - 8244	1152 - 4722	
	66		1650		5003 - 20520	2096 - 8692	3893 - 12565	1848 - 7257	
	67		2000		5891 - 26532	2466 - 11351	4610 - 16113	2271 - 9967	
Filter ePM10>50% (M5)	61	605	900	235	1372 - 7171	574 - 3065	1121 - 4589	555 - 2889	
	63		1200		1757 - 10526	710 - 4253	1492 - 6994	676 - 3873	
	66		1650		3038 - 16815	1259 - 7112	2475 - 10705	1141 - 5978	
	67		2000		3520 - 21423	1454 - 9137	2902 - 13563	1371 - 8074	
Filter ePM1<50% (F7)	61	605	900	235	783 - 5740	321 - 2447	662 - 3830	314 - 2313	
	63		1200		978 - 8094	390 - 3271	855 - 5636	378 - 2994	
	66		1650		1690 - 13002	683 - 5487	1426 - 8688	638 - 4653	
	67		2000		1908 - 16317	769 - 6932	1639 - 10868	745 - 6175	

¹ at LPHW 75/65°C, t_{in} = 20°C

² at CHW 7/12°C, t_{in} = 27°C, 48% rel. humidity

Front view

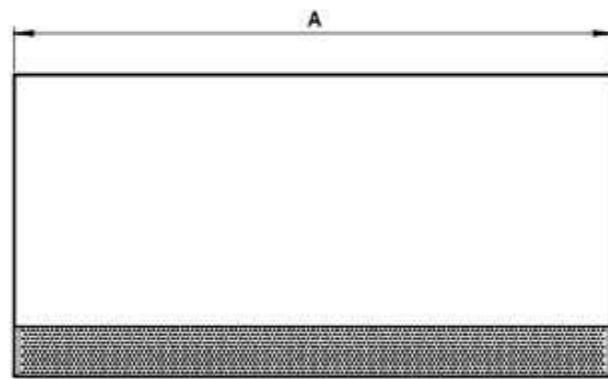

Side view (floor-mounted)

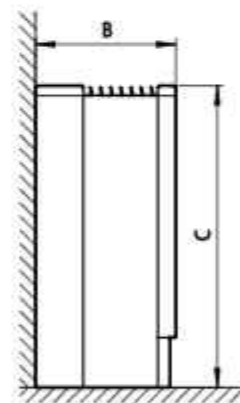

Top view

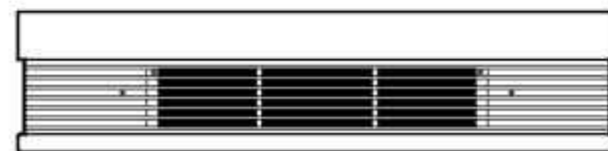

Side view (ceiling installation)

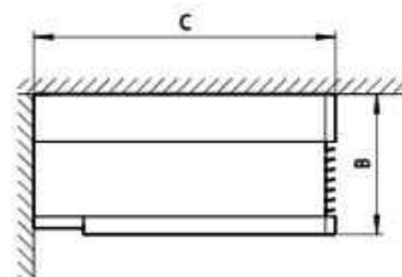

At a glance

- 1 Junction box
- 2 Heat exchanger
- 3 Connection
- 4 Condensate tray
- 5 EC or AC fan
- 6 Filter
- 7 Housing
- 8 Outlet grille
- 9 Inlet grille



Venkon XL

Heating, cooling and filtering with increased external pressure.
Flexible air conditioning solution for XL output.

Heating:
LPHW

Cooling:
CHW

Supply air in conjunction with a centralised ventilation system



Calculate your product online:
kampmanngroup.com/products/fan-coils



Technical data

Filter design	Size	Height	Width	Length	System	Heat output ¹⁾	Cooling output ²⁾	Air volume flow
		C	B	A		[kW]	[kW]	[m ³ /h]
Filter ePM10>50% (MS)	1	650	260	605	2-pipe	4.7 – 13.5	2.2 – 5.6	294 – 914
					4-pipe	3.3 – 9.0	1.9 – 4.8	
	2			905	2-pipe	5.6 – 23.4	2.7 – 9.7	341 – 1577
					4-pipe	4.6 – 18.4	2.4 – 8.4	
	3			1355	2-pipe	9.8 – 36.6	4.7 – 15.2	606 – 2460
					4-pipe	8.1 – 29.8	4.2 – 13.2	
	4			1705	2-pipe	11.4 – 47.5	5.6 – 19.7	695 – 3161
					4-pipe	9.5 – 37.2	5.0 – 17.0	

¹⁾ at LPHW 75/65 °C, room temperature 20 °C

²⁾ at CHW 7/12 °C, room temperature 27 °C, 48% rel. humidity

At a glance



- 1 Heat exchanger
- 2 Housing
- 3 Water and electrical connections
- 4 Condensate tray
- 5 EC fans
- 6 Filter

Front view

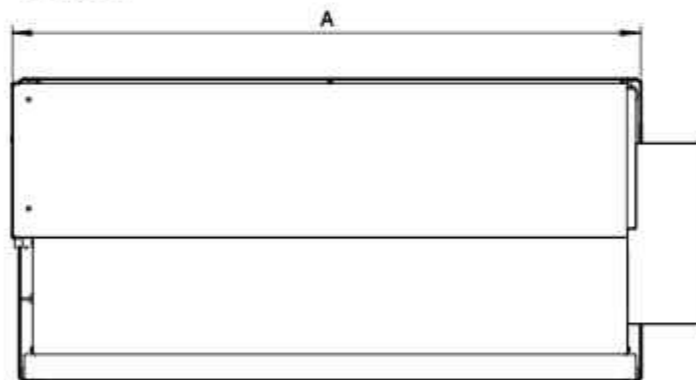

Side view

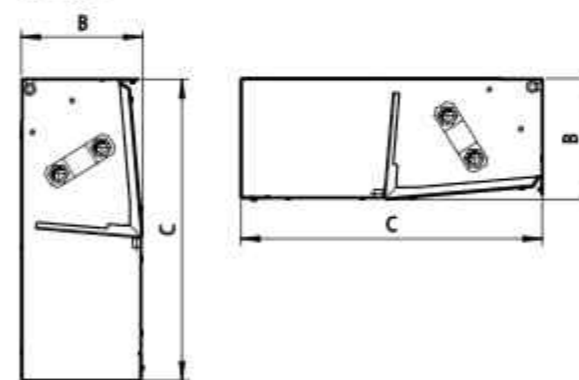

Top view



KaDeck

Flexible air conditioning for offices and new buildings.



Heating:
LPHW

Cooling:
CHW

Supply air in conjunction with a centralised ventilation system

Calculate your product online:
kampmanngroup.com/products/fan-coils



Technical data

Version	Grid dimensions [mm]	Length A [mm]	Height B		Width C [mm]	Air outlet	System	Heat output ¹⁾ [W]	Cooling output ²⁾		
			[mm]	[mm]					(wet)		(dry)
									[W]		
Wet Cooling	600 x 600	600	1200	165		same end discharge	2-pipe	610 – 3247	346 – 1666	134 – 752	
							4-pipe	468 – 1664	307 – 1348	132 – 646	
	bidirectional discharge	2-pipe	1113 – 5852	641 – 3010		244 – 1364					
		4-pipe	868 – 3091	573 – 2442		243 – 1173					
Dry Cooling	625 x 625	625	1250	165		same end discharge	2-pipe	610 – 3247	-	134 – 752	
							4-pipe	468 – 1664	-	132 – 646	
	bidirectional discharge	2-pipe	1113 – 5852	-		244 – 1364					
		4-pipe	868 – 3091	-		243 – 1173					

¹⁾ at CHW 16/18°C, t₁ = 27°C, 48% rel. humidity
²⁾ at CHW 7/12°C, t₁ = 27°C, 48% rel. humidity
³⁾ at LPHW 75/65 °C, t₁ = 20 °C

Front view (one-sided discharge)

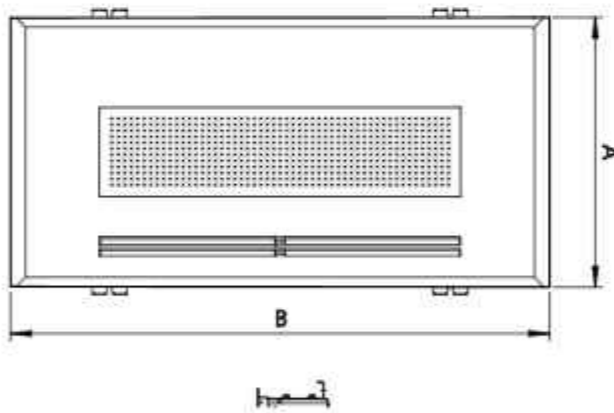

Side view (one-sided discharge)

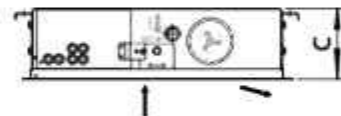

Front view (discharge at both sides)

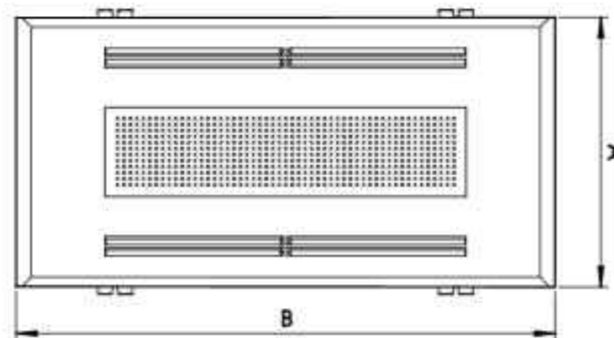

Side view (discharge at both sides)

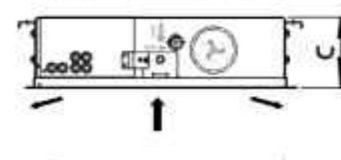

At a glance



- 1 Design casing panel
- 2 Air outlet
- 3 Air inlet with air filter
- 4 Primary air connection
- 5 Condensate pump
- 6 Water-side connection area
- 7 Condensate connection
- 8 Housing
- 9 EC tangential fan
- 10 Condensate tray
- 11 Electrical junction box
- 12 Electrical junction box

Ultra

Ceiling-mounted unit for high-end large spaces for heating, cooling and ventilation.

Heating:
LPHW

Cooling:
CHW

Supply air in conjunction with a centralised ventilation system

Whisper-quiet:
thanks to EC technology and
virtually silent sickle-blade fans



Calculate your product online:
kampmanngroup.com/products/fan-coils



Technical data

Copper-aluminium heat exchanger

Version	Size	Height	Width	Depth	Heat output ¹⁾	Cooling output ²⁾	Cooling output ³⁾	Air volume flow
		B	A	C				
		[mm]	[mm]	[mm]	[kW]	[kW]	[kW]	[m ³ /h]
EC fan, 230 V, high speed	73	330	840	750	6.5 – 15.9	---	---	590 – 1500
	84		1004	900	6.0 – 20.5	3.0 – 7.5	1.4 – 3.7	500 – 1860
	85		1004	900	7.4 – 33.2	3.7 – 12.0	1.7 – 5.7	520 – 2970
	96		1177	1050	10.2 – 53.6	5.1 – 12.3	2.2 – 8.7	680 – 5620
EC fan, 230 V, low speed	96	330	1177	1050	8.2 – 40.1	4.2 – 14.0	1.6 – 6.7	440 – 3930

¹⁾ Heat output at LPHW 75/65 °C, room temperature 20 °C

²⁾ Cooling output at CHW 7/12 °C, room temperature 27 °C, 46% rel. humidity

³⁾ Cooling output at CHW 16/18 °C, room temperature 27 °C, 46% rel. humidity

Top view

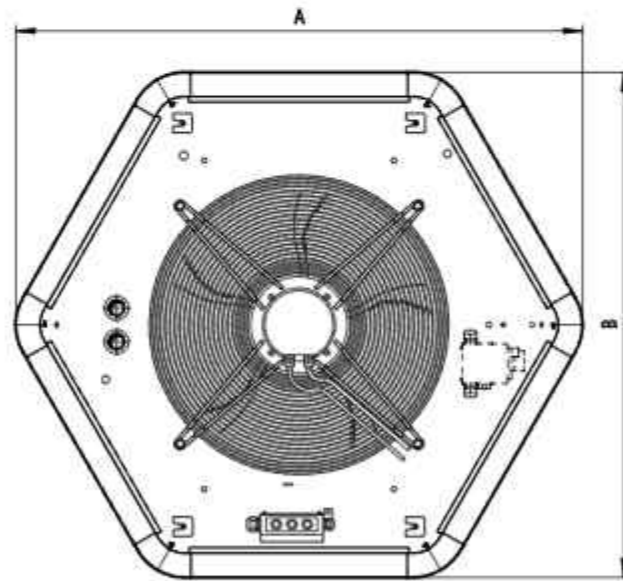

Side view

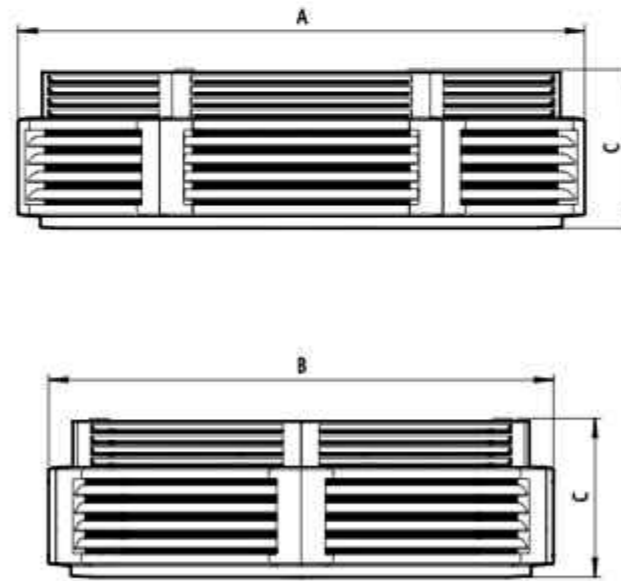

At a glance

- 1 6-section intake crown
- 2 Self-supporting plastic housing
- 3 Whisper-quiet sickle-blade EC fan
- 4 Heat exchanger
- 5 Air baffle
- 6 Plastic condensate tray
- 7 Base panel

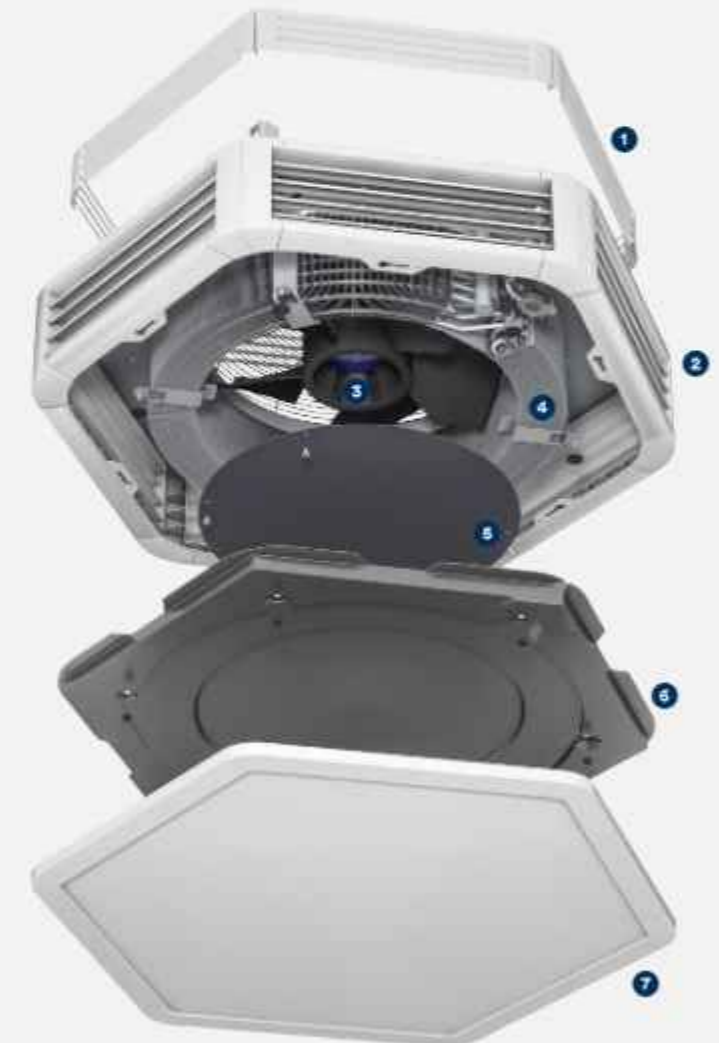

Ultra Allround

Design unit for high open ceilings up to a ceiling height of 7 m



Heating:
LPHW

Cooling:
CHW

Supply air in conjunction with a centralised ventilation system

Whisper-quiet:
thanks to EC technology

Calculate
your product online:
[kampmanngroup.com/
products/fan-coils](http://kampmanngroup.com/products/fan-coils)



Top view

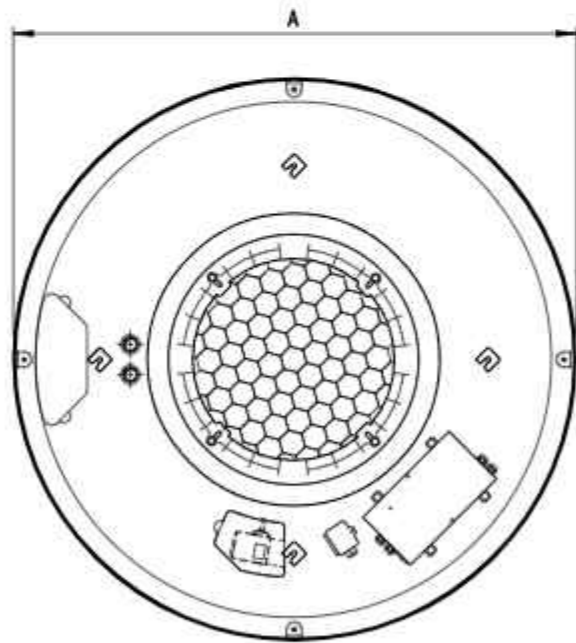

Side view

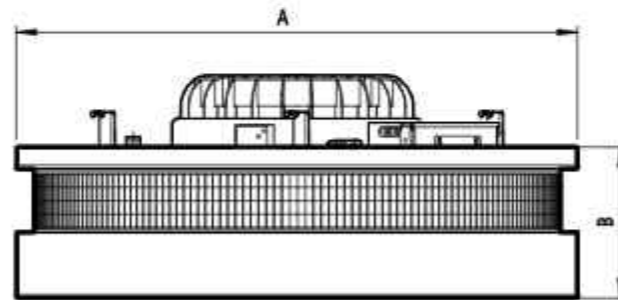

Technical data

Copper-aluminium heat exchanger

Version	Size	Height	Diameter		Heat output ¹⁾	Cooling output ²⁾	Cooling output ³⁾	Air volume flow
			B	A				
			[mm]	[mm]	[kW]	[kW]	[kW]	[m ³ /h]
EC fan, 230 V	1	515.5	1300		8.6 – 39.4	3.0 – 14.1	1.4 – 8.1	430 – 3480
	2				8.9 – 45.6	4.5 – 16.8	1.8 – 9.3	520 – 4168

¹⁾ Heat output at LPHW 75/65 °C, room temperature 20 °C

²⁾ Cooling output at CHW 7/12 °C, room temperature 27 °C, 48% rel. humidity

³⁾ Cooling output at CHW 16/18 °C, room temperature 27 °C, 48% rel. humidity

At a glance



- 1 Inlet grille (air intake)
- 2 360° horizontal air discharge grille (cooling)
- 3 EPP housing
- 4 360° vertical air discharge grille (heating)
- 5 Radial fan
- 6 Fan base plate
- 7 Heat exchanger
- 8 Condensate pump
- 9 Condensate tray
- 10 Base panel

KaCool D AF

Ceiling cassette with AtmosFeel for maximum comfort.

Heating:
LPHW

Cooling:
CHW

Supply air in conjunction with a centralised ventilation system



Calculate your product online:
kampmanngroup.com/products/fan-coils

Technical data

Size	Casing panel (LxW)	Carcass (LxW)	Carcass height	System	Cooling output ¹	Heat output ²
	A [mm]	B [mm]	C [mm]		[W]	[W]
1	680	572	296	2-pipe	1841 – 2829	4417 – 6614
				4-pipe	1843 – 2623	3265 – 4554
2-pipe				2324 – 4495	5251 – 9854	
4-pipe				2014 – 3366	3606 – 6144	
2	930	818	326	2-pipe	2602 – 4972	5901 – 11307
				4-pipe	1998 – 3964	2524 – 4331
2-pipe				3947 – 5377	9549 – 12468	
4-pipe				2523 – 4409	3014 – 4731	
3	1180	718	356	2-pipe	3627 – 7039	8483 – 16511
				4-pipe	3429 – 6186	6029 – 11224
2-pipe				4328 – 9393	8966 – 20108	
4-pipe				3915 – 7487	7256 – 13563	
4	1430	818	386	2-pipe	5514 – 12078	12411 – 28539
				4-pipe	4963 – 8454	9071 – 14602

¹ at CHW 7/12 °C, t₁ = 27 °C, 48% rel. humidity

² at LPHW 75/65 °C, t₁ = 20 °C

Front view

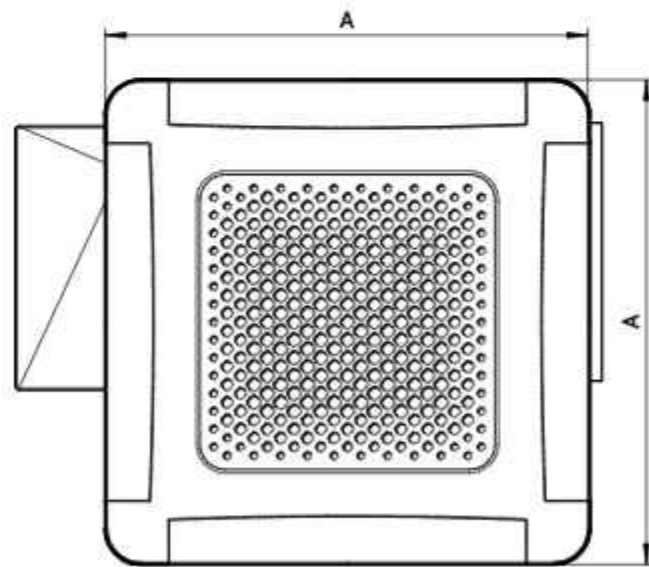

Side view

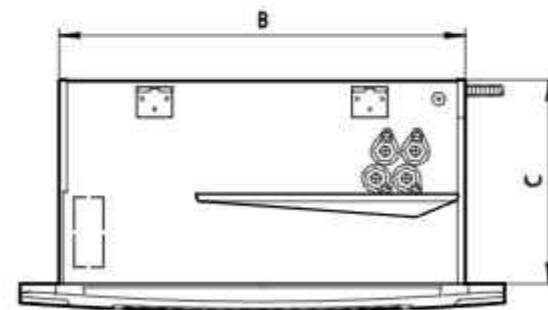

At a glance

- 1 Basic housing
- 2 Hydraulic connections
- 3 Punched opening for external air outlet
- 4 Punched opening for optional fresh air connection
- 5 Condensate tray
- 6 Fan
- 7 Heat exchanger
- 8 AtmosFeel air outlet
- 9 Air filter
- 10 Intake air grille
- 11 Condensate connection
- 12 Electrical control box

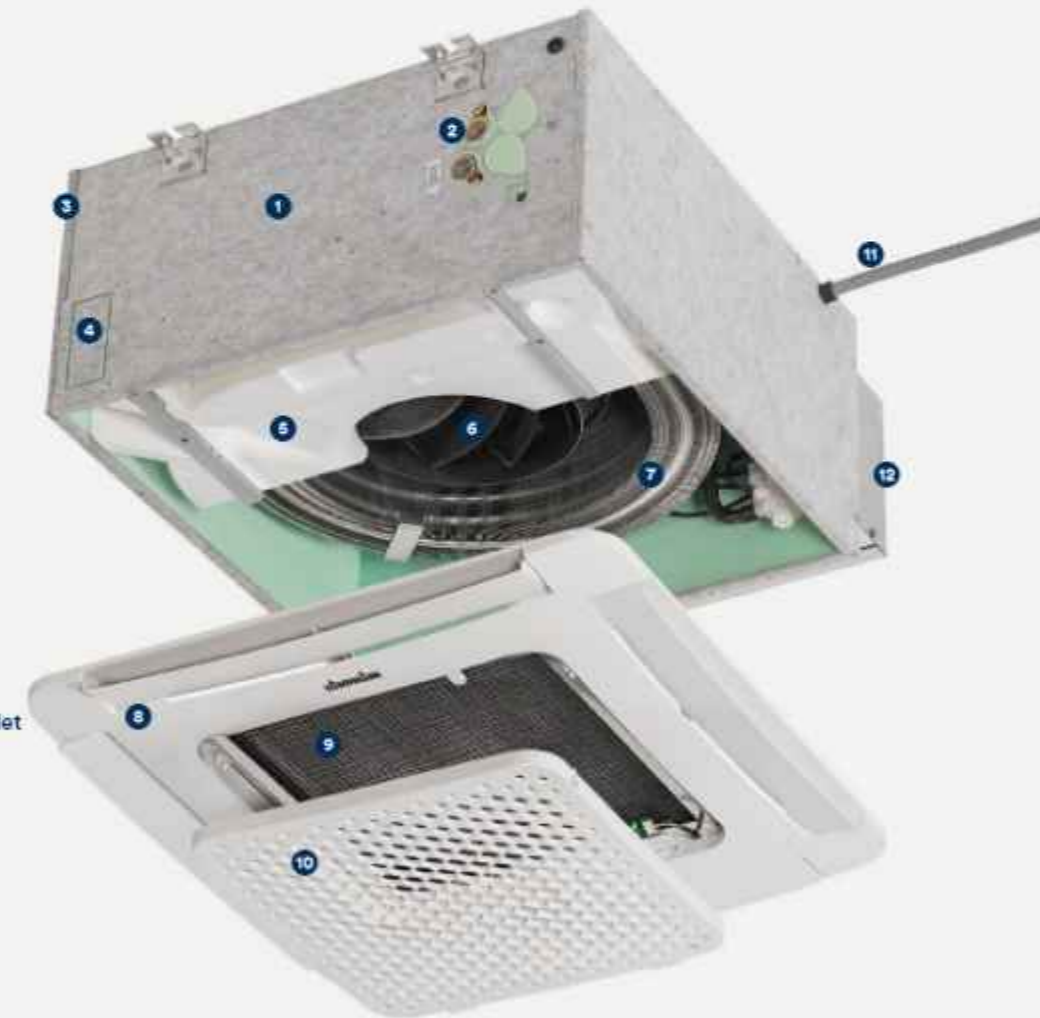

KaCool W

Design-wall-mounted unit
for heating and cooling.

Heating:
LPHW

Cooling:
CHW



Calculate your product online:
kampmanngroup.com/products/fan-coils

Front view

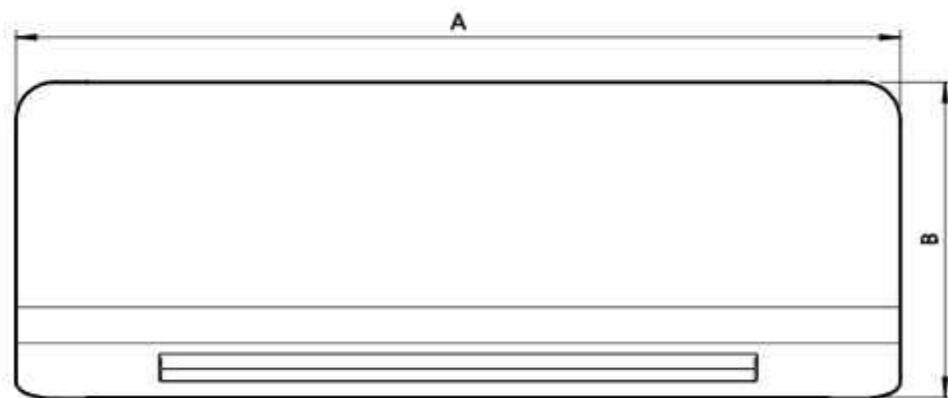

Side view

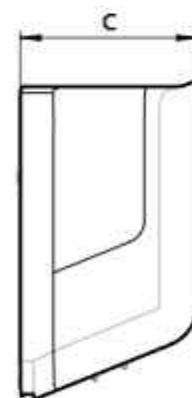

Technical data

Version	Size	Length	Height	Depth	Heat output ¹⁾	Cooling output ²⁾
		A	B	C	[W]	[W]
		[mm]	[mm]	[mm]	[m ³ /h]	[m ³ /h]
AC fan	1	930	333	185	3864 - 5726	1455 - 2027
	2				4511 - 6411	1733 - 2436
	3	1235			3862 - 7061	1520 - 2601
	4				6413 - 9685	2557 - 3851

¹⁾ at LPHW 75/65 °C, t_o = 20 °C

²⁾ at CHW 7/12 °C, t_o = 27 °C, 48 % rel. humidity

At a glance



- 1 Basic housing
- 2 Electrical junction box
- 3 Filter
- 4 Heat exchanger
- 5 Valve
- 6 Condensate tray
- 7 Condensate pump

KaCool D HC

Ceiling cassette for heating, cooling and filtering, DIN 1946-4-certified, designed for healthcare facilities.

Heating:
LPHW

Cooling:
CHW

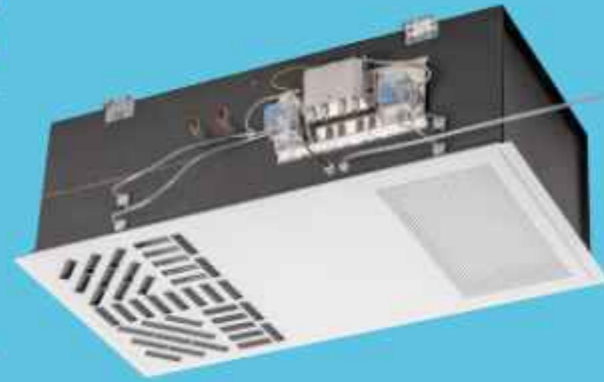

Calculate your product online:
kampmanngroup.com/products/fan-coils

Front view

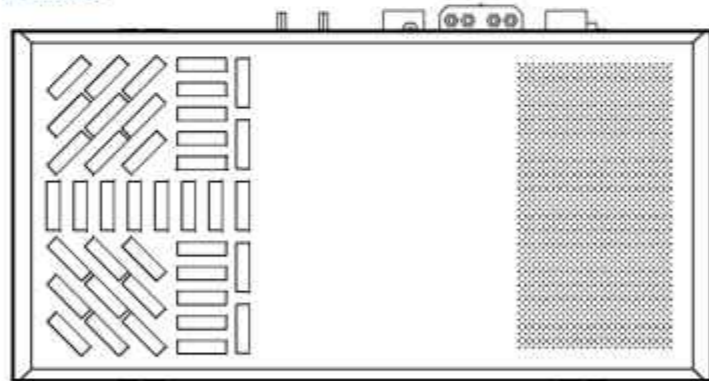

Side view

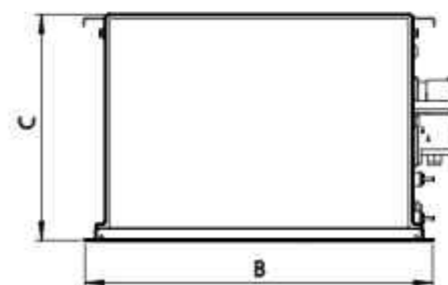
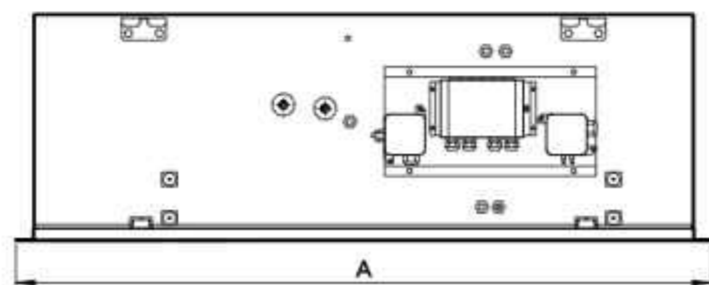

Technical data

Version	Filter class	Length		Depth		Heat output [†] [W]	Cooling output [‡] [W]
		A	B	B	C		
		[mm]	[mm]	[mm]	[mm]		
EC fan	Filter ePM1-85% (F9)	1250	674	406		470 – 6340	336 – 2923
	Filter class H14					336 – 4741	314 – 2204

[†] at LPHW 75/65 °C, t_l = 20 °C
[‡] at CHW 7/12 °C, t_l = 27 °C, 48 % rel. humidity

At a glance



- 1 Housing
- 2 Water connections
- 3 Electrical junction box
- 4 Radial fan
- 5 Heat exchanger
- 6 Filter cassette
- 7 Air outlets
- 8 Casing panel
- 9 Condensate connection

KaCool D HY

Ceiling cassette for heating, cooling and filtering, VDI 6022-certified for rooms with exacting hygiene requirements.

Heating:
LPHW

Cooling:
CHW



Calculate your product online:
kampmanngroup.com/products/fan-coils



Front view

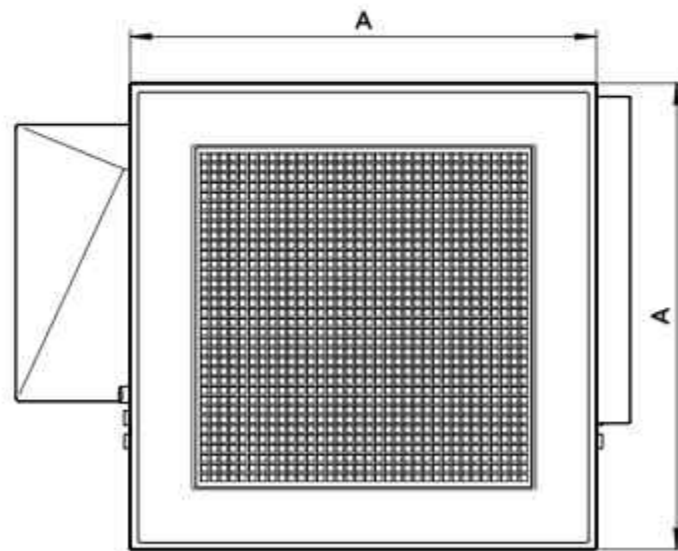

Side view

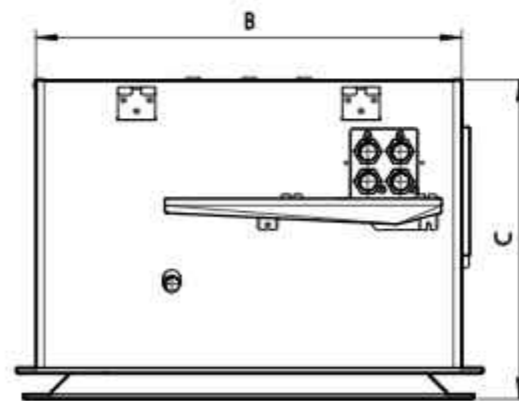

Technical data

Size	Casing panel (LxW)		Carcass height	Filter class	System	Cooling output ¹		Heat output ²	
	A	B				[W]		[W]	
	[mm]	[mm]	[mm]						
1	600	575	386	Filter ePM10-50% (M5)	2-pipe	1154 – 2627	2848 – 6170		
					4-pipe	1103 – 2418	2012 – 4218		
					2-pipe	1352 – 4126	3132 – 9080		
					4-pipe	1293 – 3138	2276 – 5712		
2	600	575	386	Filter ePM10-50% (M5)	2-pipe	1565 – 4588	3542 – 10429		
					4-pipe	1169 – 3642	1654 – 4051		
					2-pipe	2266 – 4925	5917 – 11558		
					4-pipe	1643 – 4120	2131 – 4478		
3	600	575	386	Filter ePM10-50% (M5)	2-pipe	785 – 1997	1983 – 4768		
					4-pipe	722 – 1788	1349 – 3173		
					2-pipe	865 – 3002	2045 – 6704		
					4-pipe	897 – 2419	1557 – 4360		
4	600	575	386	Filter ePM10-50% (F7)	2-pipe	1029 – 3404	2325 – 7729		
					4-pipe	751 – 2659	1168 – 3161		
					2-pipe	1433 – 3555	3986 – 8726		
					4-pipe	1154 – 3203	1601 – 3654		

¹ at CHW 7/12 °C, t₁ = 27 °C, 48% rel. humidity
² at LPHW 75/65 °C, t₁ = 20 °C

At a glance

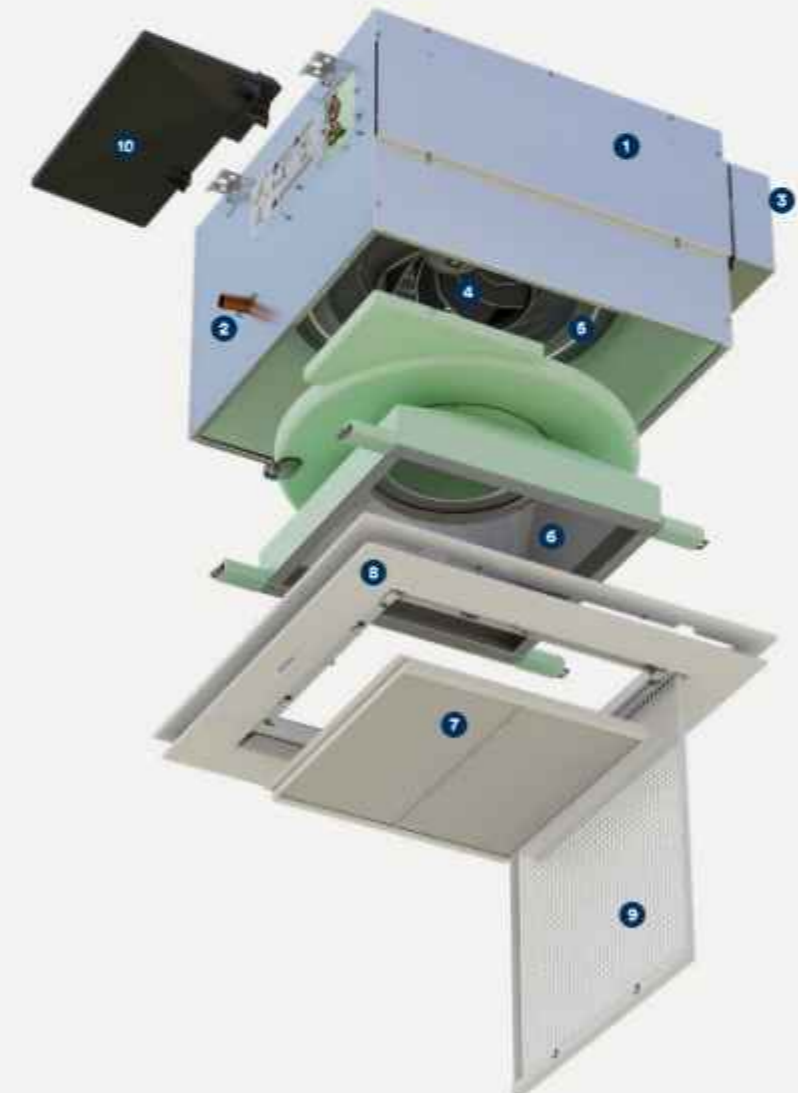

- 1 Housing
- 2 Condensate drain pipe
- 3 Electrical junction box
- 4 Radial fan
- 5 Heat exchanger
- 6 Stainless steel condensate tray
- 7 Filter
- 8 Design panel
- 9 Air intake grille
- 10 Condensate tray

PowerKon LT

High-output heat pump-based heater for residential houses

Heating:
LPHW

Cooling:
CHW

Low temperature system



Calculate your product online:
kampmanngroup.com/products/fan-coils

Technical data

Size	Length	Height	Width	Heat output [†] [W]	Cooling output ^{††} [W]
	A [mm]	B [mm]	C [mm]		
1	780			312 – 1439	221 – 1228
2	1030	618	141	520 – 2215	381 – 1974
3	1220			675 – 2874	523 – 2500

[†] at LPHW 45/40 °C, t₁ = 20°C

^{††} at CHW 7/12°C, t₁ = 27°C, 48% rel. humidity

Front view

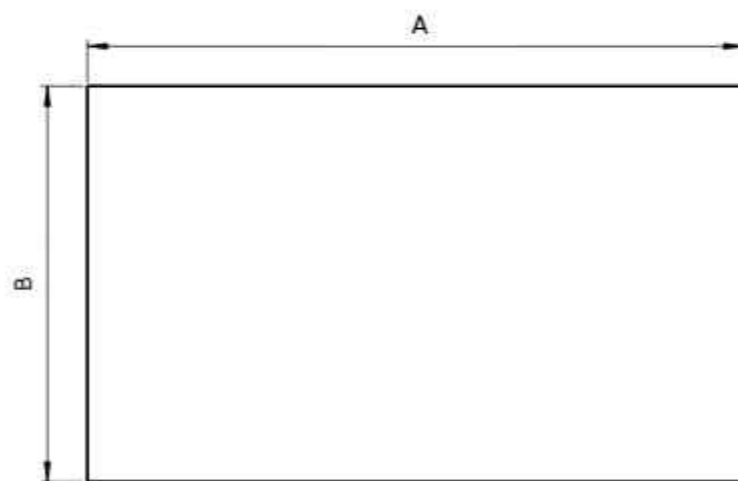

Side view



Top view

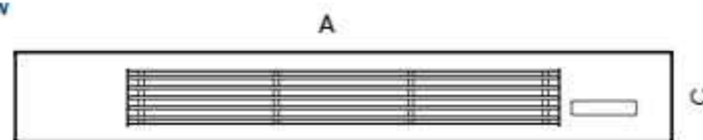

At a glance



- 1 Air discharge grille
- 2 Touch operating display
- 3 EPP carcass
- 4 Heat exchanger
- 5 Condensate tray
- 6 EC motor
- 7 Tangential fan
- 8 Air filter
- 9 Air intake grille
- 10 Casing

The right one for everyone

Variants and accessories

A wide range of accessories is available for all fan coil products. Details of them can be found with the product in question on our website.

kampmanngroup.com



Made-to-measure solutions

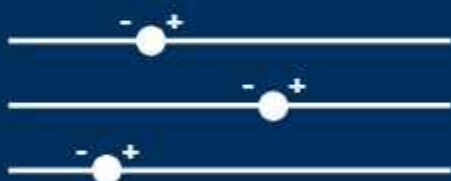

Each and every product is as tailored as a made-to-measure suit. We'd be more than happy to assist with your design. Our website offers a host of tools, such as our calculation program, watch list and our individual specification and tender descriptions. Select your preferred product design, calculate the performance data with a few clicks of the mouse, and download your customised data sheet. You can then save the calculation on your watch list or get in touch with us directly. We'd be more than happy to assist with your project design.

A wealth of diverse information is also available to download.



Venkon XL and diffusers

Venkon XL fan coils come into their own on projects where there are high heating and cooling requirements, i.e. high performance requirements. They are perfect operating in conjunction with diffusers. The air conditioning of offices is a classic application for this type of unit. Each office has its own system, consisting of a Venkon XL unit in the corridor, and a minimum of one connected diffuser in the office. With smaller rooms, multiple offices can be fed by a single Venkon XL unit.

Their shallow and slimline design makes Venkon XL units perfect for installation in suspended ceilings, ideal for installation in corridors.

The large-sized heat exchanger guarantees high output levels.

Air can then be fed into the office through the DAL358 swirl diffuser with its star-shaped discharge openings, or another similar diffuser. Thanks to the patented eccentric rollers of the DAL358, it adapts the air flow perfectly to the room conditions.

And then sound attenuators can be used to further reduce the sound pressure level for ultra-low sound emissions.



Heat Pump ready

Fan coils for use with heat pumps

The use of fan coil units in conjunction with a heat pump is becoming increasingly attractive. **Regardless of whether you want to reduce your operating costs or for reasons of sustainability**, they contribute to our aim of decarbonising our energy supply. Let us present one of the widest product ranges of units suitable for use with heat pumps – “Heat Pump ready” as it were.



Choose our fan coil units that carry this label for your future-proofed heating and cooling system.

Heat pump-compatible

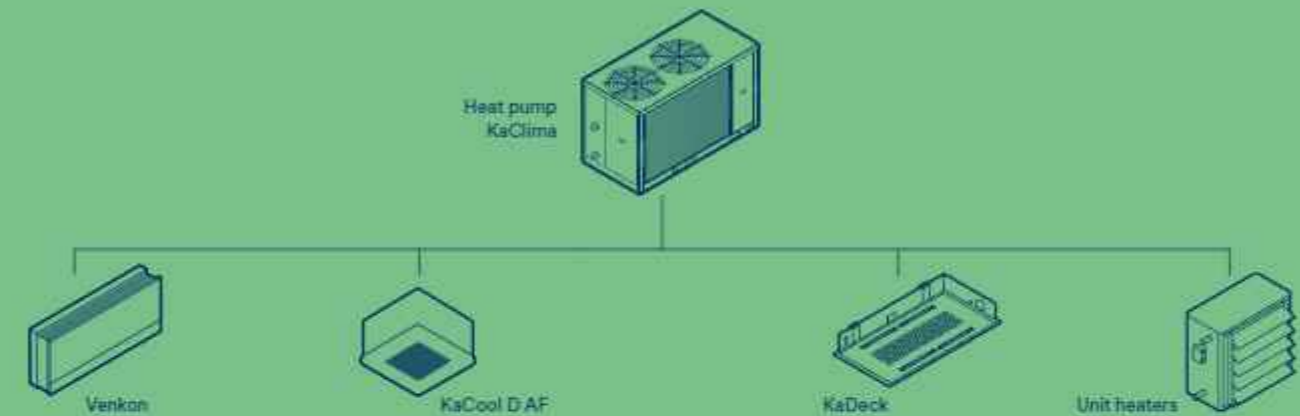

What it comes down to

> Units for use with low water temperature systems

Apart from heat pumps, many other systems can be used to reduce the use of fossil fuels. Namely systems that work with low water temperatures. But regardless of which low water temperature system is used: it only really becomes efficient when combined with economical room units. All products carrying the “Heat Pump ready” label are appropriate economical room units.

> State subsidies for heat pumps and accessories in refurbished buildings

As a developer, if you wish to install a heat pump and receive state subsidies for it, remember that the heat pump is funded, as well as everything directly associated with it. This applies to the decorator, who may have to repaint rooms, as well as to the fan coil unit for temperature control.

> Wide range for the commercial and private sector

We have the right unit for the most diverse rooms and types of building. There are so many options to combine with a heat pump. Find your solution here.

Real team players

Offices, hotels and retail stores are now not only heated and air conditioned by fan coils, but also supplied with outside air.

The focus of the hybrid system is on convenient, individual air conditioning with demand-led ventilation with the smallest possible unit dimensions.

Real team players

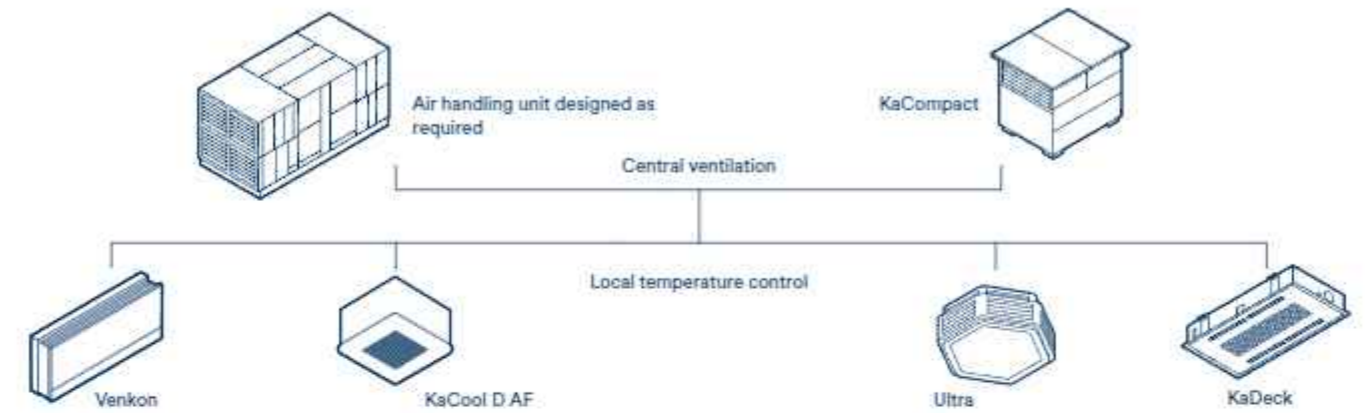

Hybrid ventilation systems are bidirectional ventilation systems with efficient heat recovery. Temperature control is provided by decentralised units inside the room and not by the central ventilation unit (air handling unit). Primary air is only fed in if required. A CO₂ sensor monitors this specific requirement. Otherwise, the decentralised units are operated with secondary air. Hybrid ventilation systems make sense as using water as a carrier medium is more efficient than air. Our fan coils are ideal for this in conjunction with our Kompakt ventilation unit or individually configured air handling units from our specialist ventilation brand NOVA.

Benefits and strengths

- > smaller air ducts
- > long filter service lives
- > efficient temperature control by decentralised units
- > less space needed for the ventilation unit
- > significantly lower energy consumption for heating
- > autonomous temperature control in different rooms

Hybrid systems are naturally designed to be individually project-based and ideally coordinated to each other.



Our controllers for fan coils

Electromechanical room control units

Room thermostat,
type 30155



Operation and temperature control of secondary air units for heating and cooling in a 2-pipe or 4-pipe system.

- > operated by turning knob
- > temperature control by fan and valve control
- > 3-stage manual fan control or continuously variable automatic control

Clock thermostat,
type 30256



Operation and temperature control of secondary air units for heating and cooling in a 2-pipe or 4-pipe system.

- > operation using function keys
- > temperature control by fan and valve control
- > 10-stage manual fan control or continuously variable automatic control

Climate controller,
type 148941



Operation and temperature control for heating and cooling in a 2-pipe or 4-pipe system.

- > operation using an LCD operating menu
- > integrated timer program
- > 10-stage manual fan control or continuously variable automatic control
- > without modbus: type 148941 (white); type 148942 (black)
- > with modbus: type 148943 (white); type 148944 (black)
- > Colour options:
 - Signal black, similar to RAL 9004
 - Pure white, similar to RAL 9010
- > Suitable for: EC units, electromechanical, e.g.:
 - 4 no. Katherm HK trench heaters,
 - 2 KaCool D AF, KaCool W, Venkon or KaDeck fan coils



KaControl - Smart room control

KaController



Operation and temperature control of up to 6 secondary air units for heating and cooling in a 2-pipe or 4-pipe system.

- > operation by multifunctional display
- > optional plug-in interface cards offer the option of connecting to higher-level control systems
- > integral temperature sensor
- > individually adjustable basic display
- > built-in weekly switching program
- > optionally available as an industrial version with IP class 65

Stand-alone or
part of the BMS



Our KaControl range is the gateway to all intelligent control logic for our products. We provide systems as a stand-alone complete solution for the operation and monitoring of heating, cooling and ventilation functions. However, often air conditioning systems need to be integrated into building automation systems (BA). KaControl also offers the appropriate interfaces, computing units and user interfaces for this. Thus, KaControl ranges from the smart room control unit to an individual user interface within the building automation network.

Research & Development

Binding performance data you can rely on.

Measurements, testing and improvements all happen in our Research & Development Centre covering over 2000 m². This where new ideas are born but also where our products are thoroughly tested in compliance with the correct standards and regulations. Everything is done to deliver the maximum efficiency and performance data you can rely on.

Acoustics, air flow and comfort

Total silence and then suddenly flurries of mist: it's not a ghost, just a glimpse of what we can offer in our FEC Research & Development Centre. We have set up our own laboratories for all kinds of simulations to replicate projects and applications as closely as possible to reality. Whether in the air flow laboratory, sound measurement lab or in the echo chamber, we tailor our products to your personal comfort level.



Challenge us.

There's not much we can't do. Then challenge us again! Why not visit us in person to see for yourself.

A warm welcome awaits you at our Research & Development Centre in Lingen (Ems) and in our Demonstration Room in Garching near Munich.

Service

We are always there to help!

Wherever you are. We have a wide range of tools to support you in your design: smart apps and calculation programs, BIM data and CAD drawings.



Delivery



Kampmann products are delivered to site sorted on pallets. The delivery can be clearly assigned to the respective floor and installation position, thanks to clear position information on the packaging.

Design

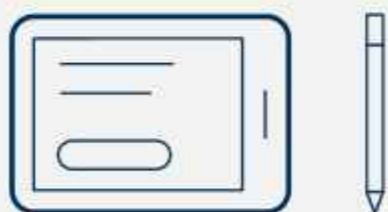

We would be pleased to produce project-specific design drawings and wiring diagrams, as well as different control options, for your project to make your design easier.

BIM data sets



Use the Kampmann BIM data sets for seamless planning processes. They include all unit dimensions, technical water and electrical connection dimensions and performance data.

Consultation



Apart from comprehensive advice on site and design of the building services systems, we can also provide the precise documentation you require for every project.

kampmanngroup.com/service



Customer service



Rely on the organisation and deployment of our global Customer Service team. Our Kampmann service specialists will provide support at 3 sites and over 130 trained contract engineers at 80 national and international sites.



Eurotheum, Frankfurt am Main

The Eurotheum is a high-rise building right in the heart of Frankfurt's banking district. Its immediate neighbour is the Main Tower, Germany's fourth tallest building. Commerz Real relaunched the Eurotheum in 2015 with the slogan "The new size". The slogan was drawing attention to the fact that the high-rise building was redesigned up to the 21st floor based on the plans of the renowned architect Peter Kulka. The "Innside" starts from the 22nd floor upwards.

Architectural style and contemporary functional needs were married to create an outstanding interior design, using only the very best materials. Kampmann KaDeck fan coils also contribute to this.



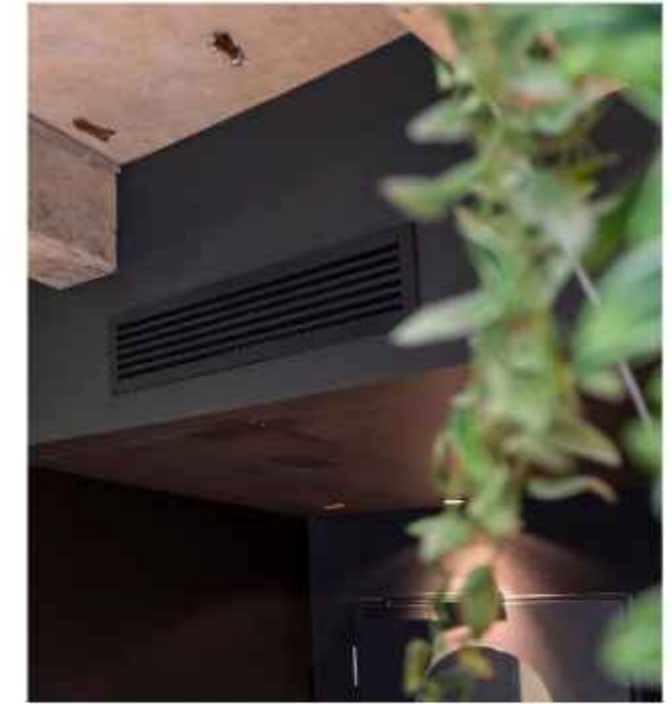

25hours Hotel The Circle, Cologne

The aim of the 25hours Hotel Company is to create experiences and places with soul. The young, dynamic hotel chain achieves this through effective design and a design concept, each closely linked to the history of the location. This is also the case with the 25hours Hotel The Circle in the heart of Cologne.

Air conditioning has long been an unwritten standard in good hotels. And Kampmann fan coils have long since evolved to become the standard unit of choice. The reasons for this are obvious. Or easy to hear (or not!). Because Kampmann Venkon fan coils are market-leading silent. This is a quality that guests very much appreciate. Thanks to EC motors, the units are also extremely efficient, with continuously variable control, and can be easily integrated into higher-level building control systems. KaCool D units provide air conditioning in public areas, such as the seminar room.





Kampmann GmbH & Co.
KGFriedrich-Ebert-Str. 128-130
49811 Lingen (Ems)
Germany

+49 591 7108-660
info@kampmanngroup.com

[kampmanngroup.com](https://www.kampmanngroup.com)

