



Premium pet food.

Individually and sustainably packed.





Efficient processing and packaging solutions for wet food and snack products.

Welcome to MULTIVAC, your experienced partner for future-proof packaging for high-quality pet food. Discover our hygienic packaging solutions for pet food, which have been proven millions of times in use, and which can contribute to greater sustainability for your products thanks to new packaging materials and concepts. Individual pack shapes, as well as precise control of modified atmosphere and defined characteristics in the packs, are today a factor in the success of many satisfied MULTIVAC customers throughout the world. From start-ups right through to industrial-scale production.

We also offer you the opportunity to brand your products attractively and individually, whether it is through fixed retail sites or your own webshop. Our packaging solutions take your brand promise all the way to the food bowl – from the printed packaging material to the printing of variable production data and best-before dates.

Our comprehensive range of products and services does not end with packaging. We can offer all the solutions from one source, ranging from highly accurate filling equipment to fully automatic boxing and palletising systems, and even including consumables such as packaging materials and labels. And thanks to our digital solutions, we can improve your production processes and increase your productivity, flexibility and transparency.

MULTIVAC solutions support you in mastering the challenges of the pet food sector, such as increasing competitive pressure, the growing need for premium brands, and the rising demand for hygienic products to human food standards – as well as more sustainable packaging.

Place your trust in MULTIVAC for innovative, reliable and sustainable solutions for the pet food sector.



Efficiently and sustainably packed. With the benefit of individual advice.

Whether your focus is on maximum shelf life, minimised packaging material use, consumer-friendly handling, exceptional product presentation, the smallest possible shelf space, or optimum volume for dispatching your packages, we will be happy to give you individual and in-depth advice.

Personal and all-encompassing.

Working closely with you, a highly motivated team of experts will develop the right packaging concept based on your ideas and needs. We also carefully take into account the special requirements of your products, such as current sustainability criteria and consumer trends.

Individual and tailored to you.

A visit to a MULTIVAC Innovation Center creates the ideal environment for comprehensive advice and individual packaging development, as well as conclusive pack tests. The infrastructure in these facilities offers plenty of space

for new ideas, and this means that you can hold tomorrow's pack in your hands today. Prototypes and small production series make decision and approval processes more efficient, and your individual pack samples support you in making presentations to sales partners.

Our range of consulting services includes:

- Market observation and analysis of trends
- Food analysis
- Pack design
- Technical feasibility studies
- Packaging and material trials
- Creating prototypes
- Small production series



Reliably produced and sold. With individually tailored packs.

Thanks to our efficient technology and decades of experience, we can produce tailor-made packs with individual shapes and customised features. Whether it is modified atmosphere for optimum shelf life, attractive branding, pack opening aids or odour barrier, we translate your requirements reliably and precisely.

Simple and clean.

User-friendly handling means to us, that the product can be removed from the pack easily, cleanly and without waste, even when an impatient muzzle is already waiting at the bowl. Integrated opening aids on the pack ensure that it is opened conveniently and reliably without any implements. Reclosure features are useful for products such as snacks, which are removed repeatedly from the pack.

Hygienic and secure.

We offer the same precisely controlled atmosphere in the pack for pet food, as we do for human food: Packaging under vacuum or modified atmosphere (MAP), and always with highly controllable residual oxygen content.

Vacuum packs made of flexible film are particularly functional and material-efficient, and they can be handled very reliably in downstream processes. Packs with modified atmosphere buffer the product by means of a header space, and they can usually be stacked easily, as well as offering flat surfaces for very simple labelling and printing.

Sustainable and efficient.

Our packaging materials offer tailored barrier properties for oxygen, moisture, odour, puncture resistance and much more – for secure handling along your logistics chain, from the packaging stage right up to the four-legged friend. Sustainable and recyclable packaging materials made from mono films and fibre-based materials can be run on MULTIVAC systems as efficiently and reliably as conventional multi-layer films.

Our machines enable single packs and multiple packs to be produced on the same machine, and the individual portions can be separated by means of perforation between the packs. So you can remain flexible and efficient in production, even with variety packs.

Attractive and distinctive.

MULTIVAC solutions offer you the opportunity to present your products attractively and uniquely. Equally powerful, whether it is via a fixed retail site or your own webshop. Our packaging solutions take your brand promise all the way to the food bowl, for example using printed packaging materials, decorative or promotional labels, sleeves for multiple packs, as well as printing of variable production data and best-before dates.

Efficiently processed and packed. With the right technology.

Be on the safe side, so that your pet food quality and cost-effectiveness are right. With integrated processing and packaging solutions, which offer individual added value – for example, loading, packing, labelling, inspecting and box packing. From one source. Thanks to our machines and lines, which can be scaled very flexibly, we are able to support individual customers of every company size as personally and directly as we do multinational companies.

Packing efficiently

When it comes to the primary packaging of your products, we can offer you a wide range of packaging technology, which provides different benefits depending on the application and product:

- Thermoformed packs
- Tray packs
- Pouch packs
- Flowpacks

In the pet food sector many of our customers place their trust in thermoforming packaging machines as a solution, which is particularly flexible and efficient in terms of packaging materials. Instead of having to stock pallets of cans or pre-made trays, just a few compact web rolls of material are sufficient.

Other benefits: Individual pack shapes can be achieved very simply and cost-effectively with thermoforming packaging machines. Thanks to versatile vario dies with dividers or forming plates, you can change the pack size quickly and easily. And with just a few hand movements at the cutting system on the machine, you can convert from single packs to multiple packs, which are separated by means of perforation.

The range of available packaging materials also meets all the possible applications - from flexible film packs to rigid packs, including sustainable and recyclable materials.

We can also advise you on the areas of use for tray packs, pouches and flowpacks in the pet food sector, offering open and comprehensive advice on each technology. Just contact us!

Process automatically.

In addition to our own processing solutions, such as the MULTIVAC Centrifuge Feeder (MCF) and our automatic loading systems, we also integrate products from our technology partners seamlessly into automated lines. Flexible and efficient filling and portioning systems are used for pet food, for example for portioning, dosing, forming, separating and cutting.

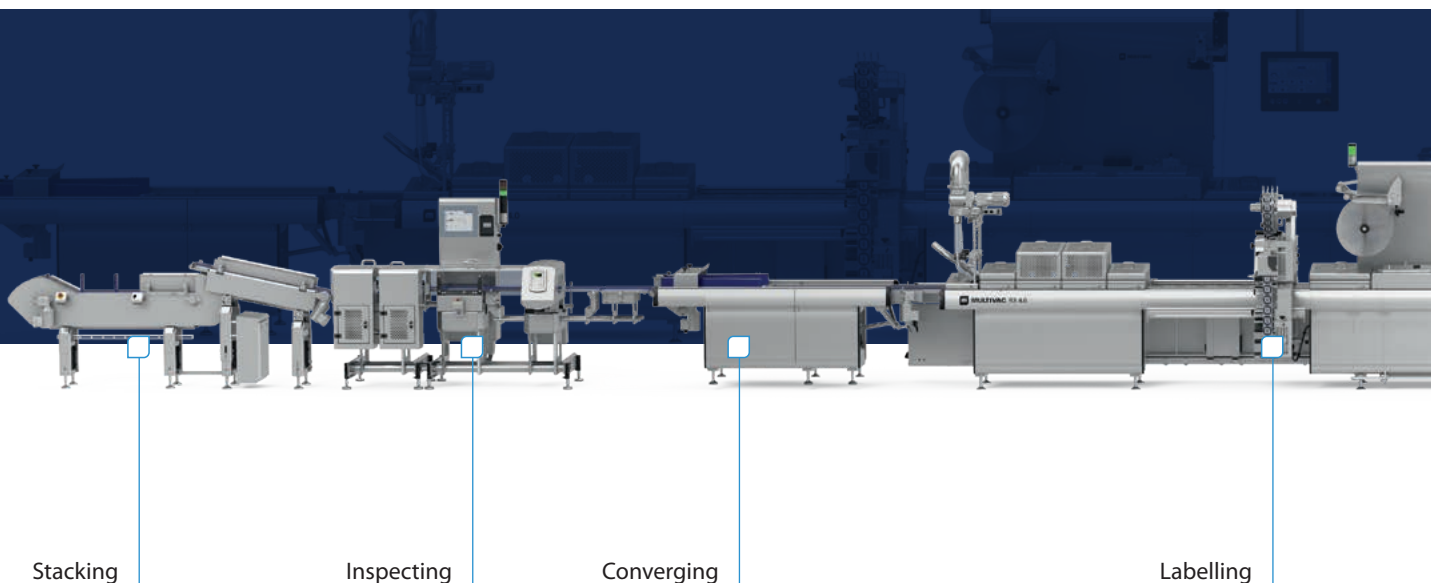

Label and print flexibly.

Our packs take your brand promise all the way to the food bowl. And when it comes to labelling and printing, our solutions are also focused on your individual needs. With our cross web labellers and direct web printers, which are fully integrated into the thermoforming packaging machine, we have a range of particularly space-saving systems. When equipped with printers, they can also add variable data such as best-before dates, batch numbers and barcodes to labels or film.

Conveyor belt labellers, which are situated downstream of the packaging system in automatic lines, can apply not only standard labels to the packs, but if designed as MULTIVAC Full Wrap labellers, they can automatically apply sleeve-like labels, for example to multiple packs.

Inspect seamlessly.

MULTIVAC systems for quality inspection ensure that your products and packs meet the highest quality and safety standards.

Our metal detectors and X-ray inspection systems, which operate without physical contact with the packs, are able to detect undesirable foreign objects very reliably, and they can be adjusted with great precision. Our checkweighers inspect fixed-weight packs to ensure that the required tolerances are met. And our visual inspection systems can check the presence and legibility of labels and printed information such as logos, 2D/3D codes etc.

Our quality inspection systems are equipped with ejection devices, which remove detected reject packs very reliably.

Box pack automatically.

MULTIVAC offers flexible solutions for automated secondary packaging in folding cartons, boxes and containers, as well as palletising. These provide reliable and fully integrated solutions, which quickly pay for themselves.

Benefit for life.

Our digital products and services contribute to increasing the productivity, flexibility and transparency of your processes. From the particularly simple HMI user guidance throughout the line, and right up to the unique MULTIVAC Smart Services for optimising efficiency.

MULTIVAC CustomCare services comprise a wide range of first-class after-sales products and services, which are perfectly tailored to your requirements. They range from preventive maintenance contracts, through to remote assistance, live support, local service, genuine spare parts, machine optimisation inspections, modernisation work, express repairs and of course our Helpdesk, and right up to the user-friendly myMULTIVAC Customer Portal, which is your access to the MULTIVAC world.

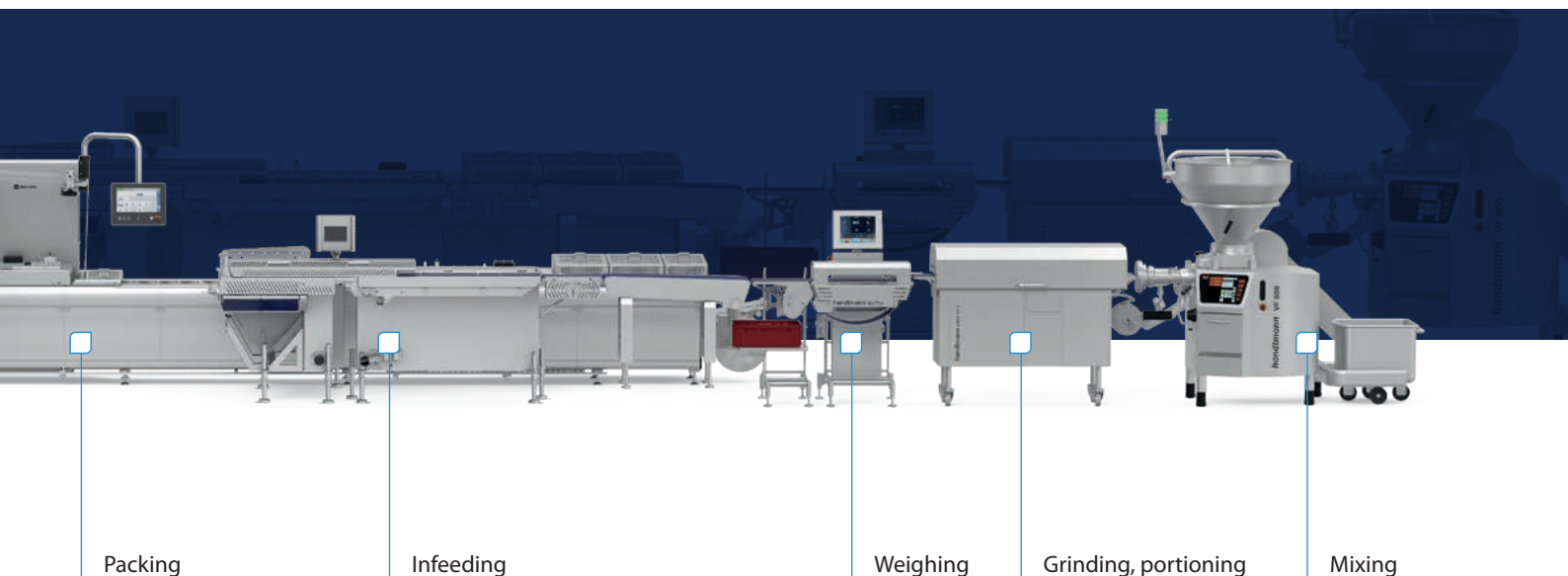

Line solution for dosed raw food. Hygienic and efficient.

Application:

Raw food (BARF) in a hygienic vacuum pack with a long shelf life, portion weight 250 g and 500 g.

Product:

Fresh meat from whole meat pieces, tripe, innards and vegetable/meat mixes.

Processing:

Clean and precise cutting to weight of the meat products, as well as direct portioning into the thermoformed packs.

Pack:

Thermoformed pack made of flexible lower web and upper web with low residual oxygen content for optimum shelf life.

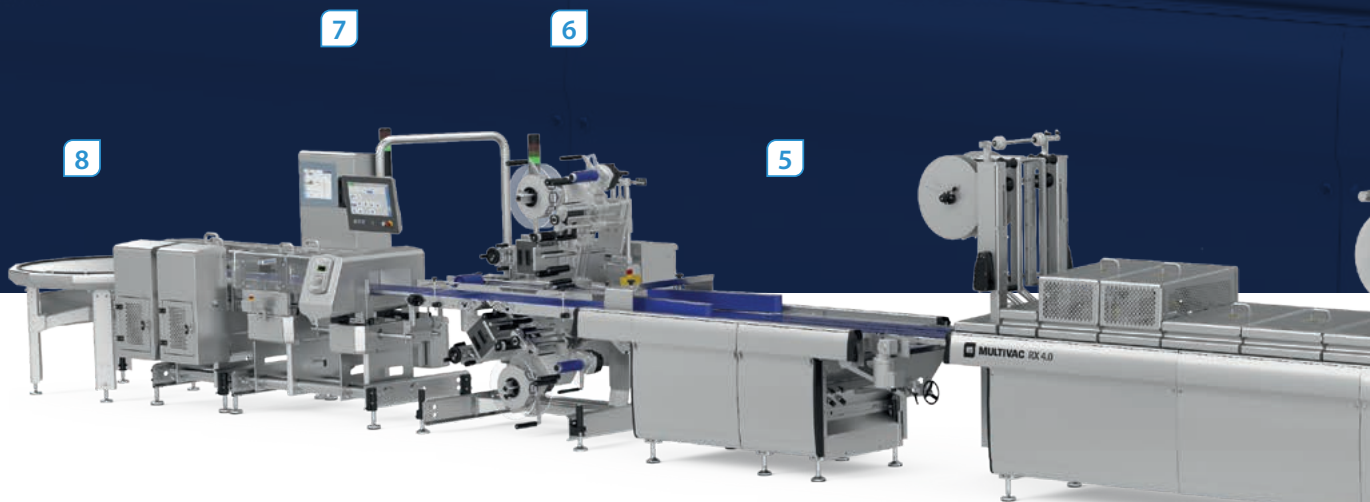

Sample calculation

Output of the line*	Packs/min	Packs/h	Output/h
Format 2 x 3, 7 cycles/min	42	2,520	250 g: 630 kg/h
Format 3 x 8, 6 cycles/min	144	8,640	500 g: 4,320 kg/h

^{*)} All output figures are approximate values, which depend on the nature of the product and the equipment on the machines, and they are not therefore binding.



Line for dosed raw food

- 1 Variomix IKVM 500 mixer
- 2 VF 820 vacuum filler
- 3 RX 4.0 thermoforming packaging machine
- 4 DV 85-4 dosing valve
- 5 MBS 200 pack arranging system
- 6 L 310 labeller
- 7 Checkweigher with I 211 metal detector
- 8 MRT 100 rotating table

Line solution for portioned wet food. Flexible and efficient in terms of packaging material.

Application:

Raw food (BARF) in a hygienic vacuum pack with a long shelf life, portion weight 250 g and 500 g.

Product:

Fresh meat from whole meat pieces, tripe, innards and vegetable/meat mixes.

Processing:

Clean and precise cutting to weight of the meat products, as well as direct portioning into the thermoformed packs.

Pack:

Thermoformed pack made of flexible lower web and upper web with low residual oxygen content for optimum shelf life.



Sample calculation

Output of the line*	Packs/min	Packs/h	Output/h
Format 4 x 3, 12 cycles/min	144	8,640	250 g: 2,160 kg/h
Format 3 x 3, 12 cycles/min	108	6,480	500 g: 3,230 kg/h

^{*)} All output figures are approximate values, which depend on the nature of the product and the equipment on the machines, and they are not therefore binding.

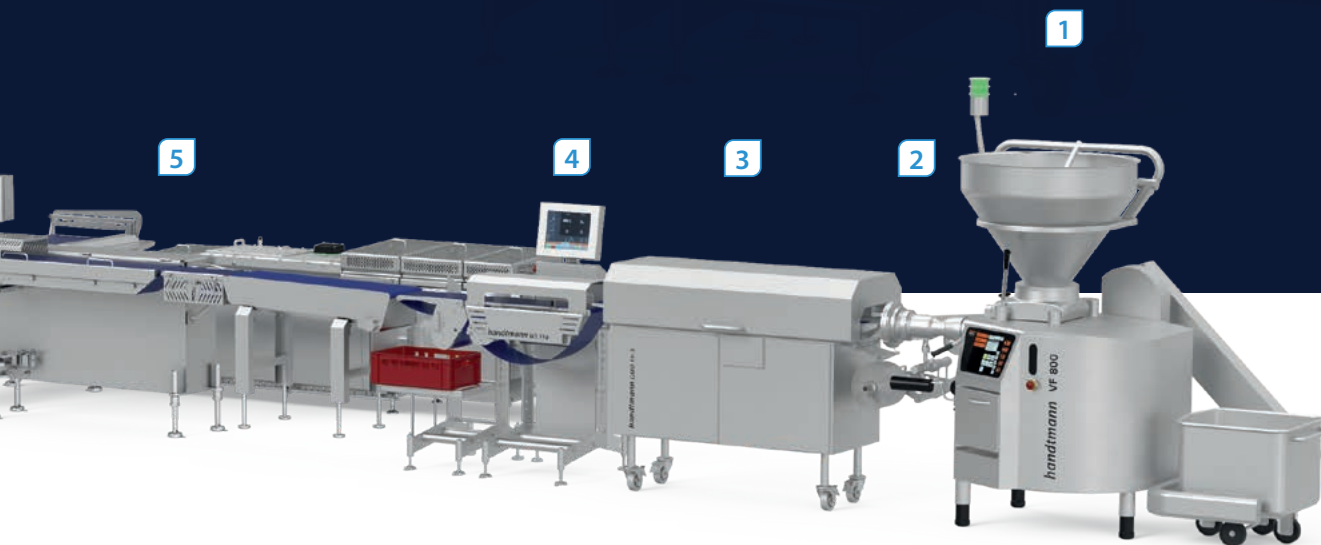

Line for portioned wet food

- 1** VF 820 vacuum filler **2** GD 451 grinding system **3** GMD 99-3 minced meat portioning machine
- 4** WS 910 weighing unit **5** Thom MLL loading system **6** RX 4.0 thermoforming packaging machine
- 7** CL2 cross web labeller **8** MBS 200 pack arranging system **9** Checkweigher with I 211 metal detector
- 10** MPS 102 pack stacker

Line solution for cooked wet food. Clean and accurate for portion weight.

Application:

Cooked wet food in a hygienic vacuum pack with a long shelf life, portion weight 250 g (2 portions of 125 g each)

Product:

Meat meals, cooked or mixed with plant-based constituents.

Processing:

The liquid or paste-like mass is dosed precisely to weight into the multi-track thermoforming packaging machine.

Pack:

Thermoformed pack made of flexible lower web and upper web with low residual oxygen content for optimum shelf life. The retail pack consists of two portion packs of 125 g each, which can be separated easily and hygienically by means of perforation.

6

5

4



Sample calculation

Output of the line*	Packs/min	Packs/h	Output/h
Format 6 x 4, 10 cycles/min	240	14,400	250 g: 3,600 kg/h

^{*)} All output figures are approximate values, which depend on the nature of the product and the equipment on the machines, and they are not therefore binding.

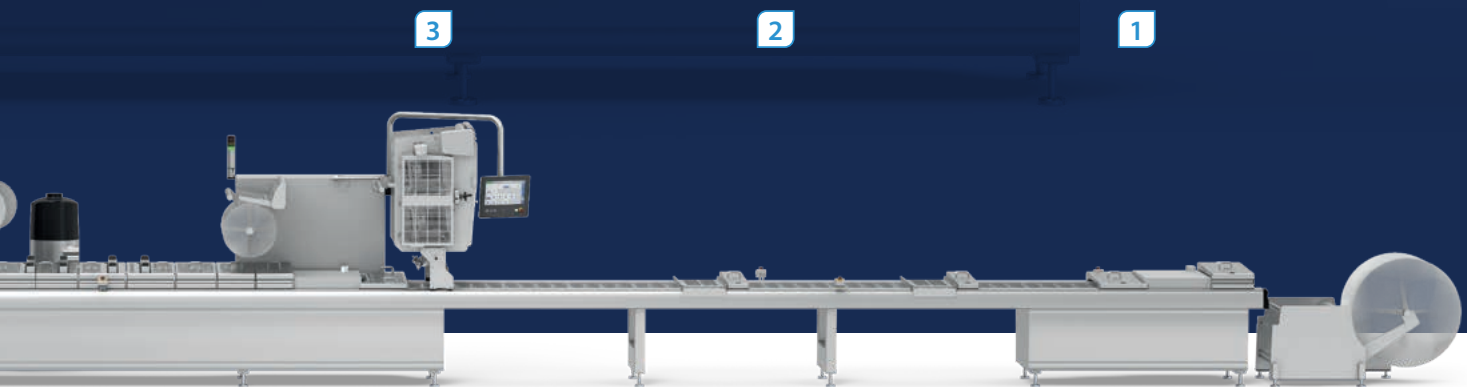

Line for cooked wet food.

- 1 Tiefziehverpackungsmaschine RX 4.0 2 Kniefreier Einlegebereich zur Integration von Dosiersystemen 3 Foliendirektdrucker
4 Handhabungssystem zur Vereinzlung H 130 5 Kontrollwaage mit Metalldetektor I 211 6 2x Stapleinrichtung MPS 102

Line solution for snack products. Fully automatic and efficient.

Application:

Cat or dog sticks in a hygienic vacuum pack with a long shelf life, perforated for easy and clean dispensing of the individual sticks.

- 50 g pack = 2 x 5 sticks, each 5 gr
- 12 g pack = 2 x 1 stick, each 6 g

Product:

Dry food in small portion sizes as treats.

Processing:

Different starting materials are precisely formed to weight into various sizes and shapes of sticks.

Pack:

- Automated loading into the thermoformed packs by MULTIVAC handling modules
- Multiple packs (2 sticks, 10 sticks) with perforation and low residual oxygen content for optimum shelf life.

2

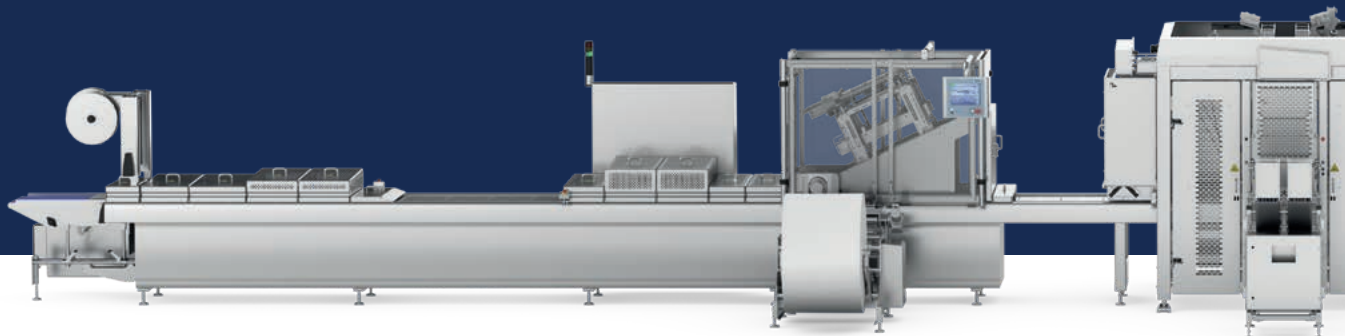

Sample calculation

Output of the line*	Packs/min	Packs/h	Output/h
Format 20 x 2, 11 cycles/min	440	26,400	10 x 5 g: 1,320 kg/h
Format 16 x 2, 14 cycles/min	448	26,880	2 x 6 g: 1,612 kg/h

^{*)} All output figures are approximate values, which depend on the nature of the product and the equipment on the machines, and they are not therefore binding.

1



Line for snack products

1 4 x H 242 loading systems 2 RX 4.0 thermoforming packaging machine





This is what real partnership looks like.

MULTIVAC's expertise in packaging solutions is both environmentally and economically sustainable. Our range of products, systems and customised services ensure that the highest levels of energy efficiency and productivity are achieved. Over the entire life cycle of your equipment. At MULTIVAC you will find experts in your product sector, who are very familiar with all the regulations and standards of your industry. Since we are totally focused on your products and target groups, our collaboration with you often begins in our TIC and TAC Technology Centers, where we offer advice on applications and packs as well as training courses.

This solid basis provides almost unlimited possibilities for you: a wide range of packaging technologies, Industry 4.0 compatible automation solutions, and labelling as well as quality control systems. Thanks to digitalisation with real-time analytical tools such as MULTIVAC Smart Services, we ensure from the outset that maximum operating security, process reliability and line efficiency are achieved. So that you can get the optimum from your production equipment, and also amortise your investment within the shortest possible time. Thanks to a low TCO (Total Cost of Ownership) and energy costs.

And best of all: with MULTIVAC the high level of equipment availability can be planned over the long term. In accordance with the concept of OEE (Overall Equipment Effectiveness), we provide total support for you with our CustomCare After Sales Solutions – from preventive maintenance contracts, remote assistance, MULTIVAC Live Support, our Emergency Helpdesk and optimisation audits, right up to spare parts, machine retrofits and express repairs, and even including our user-friendly myMULTIVAC Customer Portal, which is your direct access to the MULTIVAC world.

More than 1,000 MULTIVAC CustomCare staff worldwide work around the clock 365 days a year to guarantee your success and 100 % satisfaction.



MULTIVAC is there for you on-site, world- wide.

Our sales and service network comprises more than 85 subsidiaries. We are present on all continents and in all important markets. At all times and in all places, more than 1,000 consultants and service technicians will offer you expert advice and a comprehensive range of services covering all areas of packaging, as well as support you on your way to the best possible and most efficient overall solution. Our technical service, combined with rapid availability of spare parts, ensures all MULTIVAC machines installed worldwide are at maximum readiness.





MULTIMAT





www.multivac.com



MULTIVAC is part of the R-Cycle initiative across all companies. The common objective is to drive the loop system for plastic packs forward, based on an open and globally applicable tracing standard.

MULTIVAC supports the Blue Competence initiative of the Association of German Machinery and Equipment Manufacturers (VDMA).

110260851 | MULTIVAC 05/2024 | In keeping with improvements, designs and specifications are subject to change without notice. MULTIVAC is a registered trade name of MULTIVAC Sepp Hagenmüller SE & Co. KG.