

EV Chargers



Performance Range

As electric vehicles become widespread, so must the infrastructure to charge them. One of the main requirements for the widespread use of electric vehicles is an accessible EV charging infrastructure. Governments and industries worldwide are investing in charging infrastructures, with a growing trend toward bidirectional charging.

Availability and costs are the key to success in the fast growing EV Charger market. As the specialist in power electronics, we use state-of-the-art topologies featuring standard components, guaranteeing both excellent efficiency and availability. Semikron Danfoss offers a comprehensive portfolio of products that meet the needs of fast charge equipment from as little as 8kW up to the megawatt range.





- DC wall boxes
- Depot chargers
- Highway chargers
- Heavy-duty vehicle chargers

Compact designs and high power density

High reliability to reduce downtime

Forward-looking topologies

High efficiency

Products

SEMITOP E

SEMiX 2

SEMiX 5

SEMiX 3 Press-Fit

SEMITRANS Classic

SEMIPACK

Drivers

Power Electronic Stacks



PRODUCT HIGHLIGHT

The Ultimate Partner for Silicon Carbide Power Modules

For power dense EV chargers, silicon carbide enables freedom of design for today's power electronics. Silicon carbide exhibits extremely low switching losses which yield less cooling effort and higher efficiency. The result is smaller, lighter power converters and reduced energy usage.

The industry standard SEMITOP E1 and E2 feature high thermal performance and low stray inductance. Standard pinout configurations allow for multiple sourcing to ensure supply chain safety.

Key Features

Fast switching SiC reduces losses, simplifying cooling effort

Multiple chip sources for improved supply chain safety

Matrix hole pattern for flexible topologies and low inductance

3-level TNPC topology enables reduced magnetics size and cost

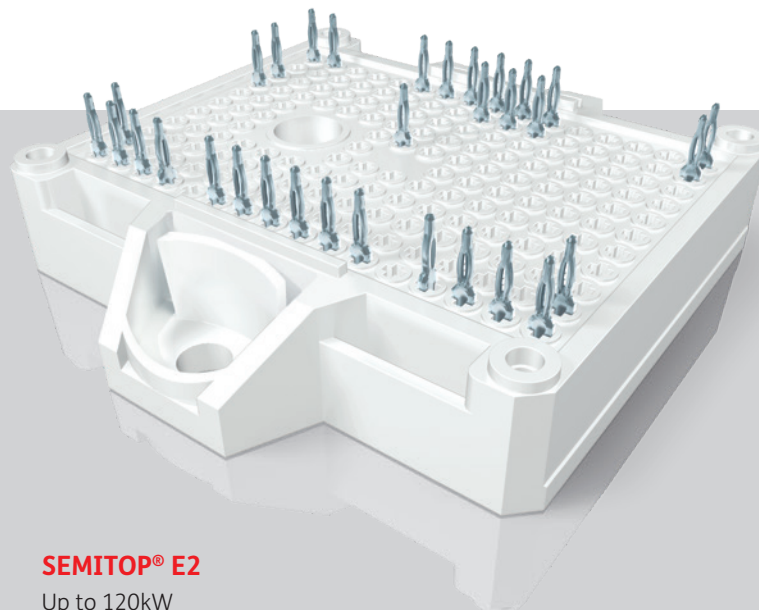
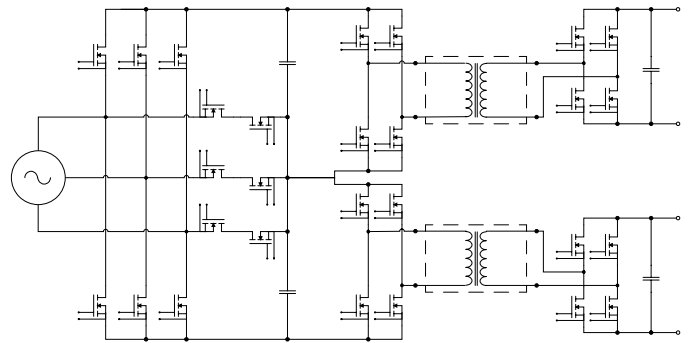
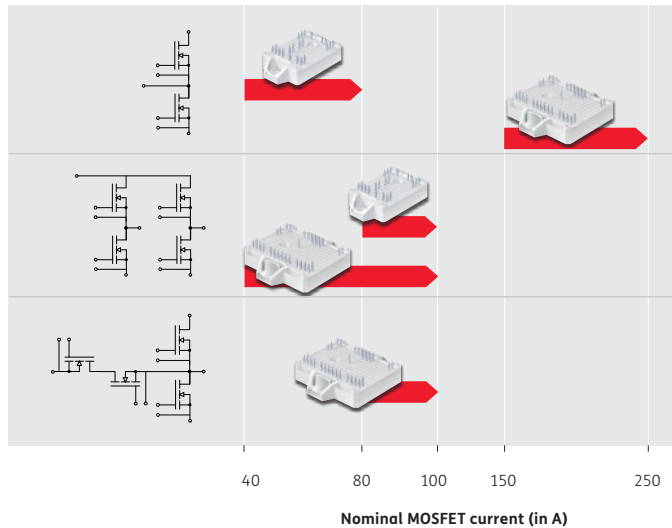

SEMITOP® E2

Up to 120kW

PRODUCT HIGHLIGHT

Industry Standard Combined with Superior Performance

DC fast chargers require a power dense PFC, DC/DC, and output rectifier, all available in the SEMITOP E1/E2 packages. With a low inductance design, fast switching Si and SiC chips may be used to their full potential. Achieve supply chain safety with this industrial standard module in a wide array of topologies.

Key Features

- Low inductance package
- Multiple sourcing down to chip level
- Optimized footprint
- Flexible architecture
- 2-screw concept
- Press-fit terminals
- 12mm module height
- No baseplate

The thermal resistance is up 20% lower than the closest competitor using standard thermal paste. Using High Performance Thermal Paste (HPTP), a further 25% reduction is possible.

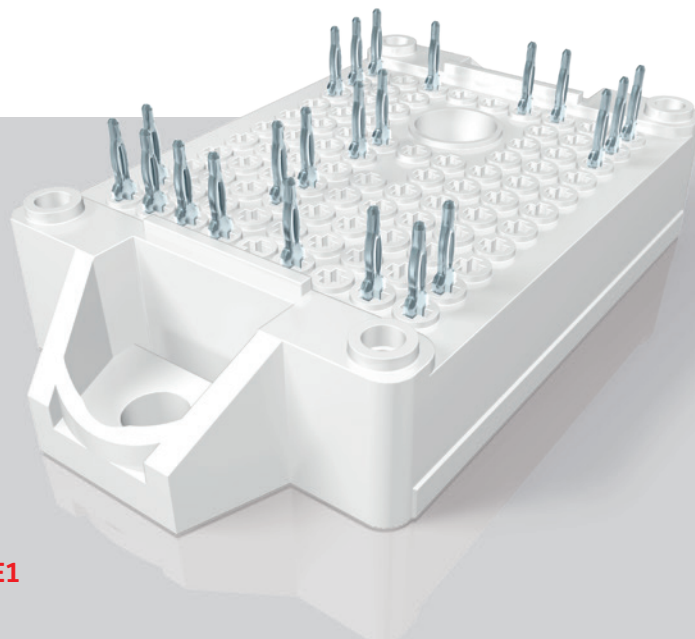
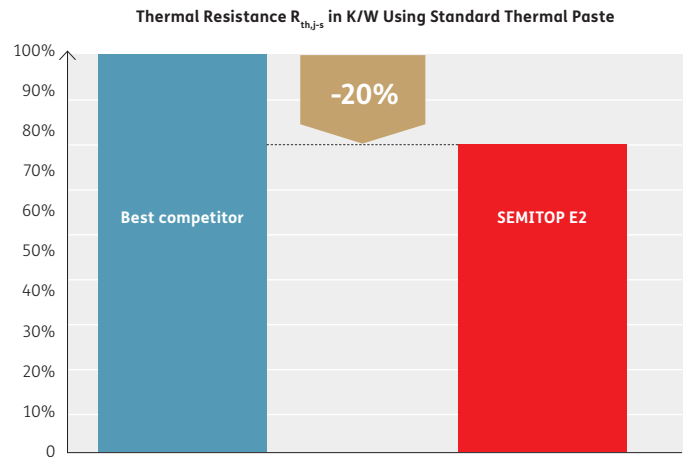

SEMITOP® E1
Up to 45kW



Product Portfolio

Power Modules



SEMIPACK®

800V up to 2200V

Bipolar Modules from the Market Leader

6 housing sizes SEMIPACK 1 to 6

800V to 2200V: 20A to 1360A

Semikron Danfoss diode and thyristor chips

Diode and thyristor in un-, half- and full-controlled topologies

Different technologies for certain packages: high reliability pressure contact or cost-effective wire bonded modules

Enhanced isolation voltage of 4.8kV/1s available on request



SEMIX® 3 Press-Fit

100kW - 400kW

Exceeding the Standard for Superior Performance

Industry standard press-fit design with 17mm high housing height

650V/1200V/1700V IGBT: 225A to 900A
1200V Hybrid SiC: 600A

Half-bridge and split NPC topologies

Direct driver assembly

Available with integrated shunt resistor

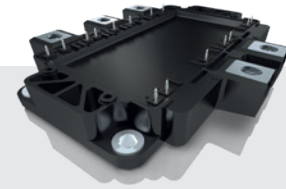

SEMIX® 5

50kW - 150kW

Extended Standard for Superior Thermal and Dynamic Performance

Industry standard baseplate module

650V / 1200V / 1700V IGBT: 150A to 400A

Sixpack, NPC, TNPC, PFC, and half-controlled bridge rectifier topologies

Optimized module layout for maximum heat transfer

Enhanced thermal and electrical diode performance



SEMITRANS® Classic

50kW - 600kW

The Proven Power Electronics Package

Robust industry standard package for multiple sourcing in six housing sizes

600V / 650V / 1200V / 1700V IGBT:

25A to 900A

1200V SiC: 125A to 500A

Half-bridge, single switch and brake chopper topology

Multiple IGBT and SiC sources

Extended 62mm portfolio:

1200V IGBT: 800A

1700V IGBT: 500A

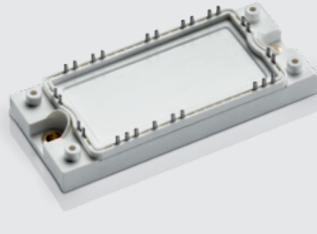

SEMIX® 2

Up to 50kW

Industry Standard for EV Charging

Press-fit pins

1200V: 130A, 8mΩ Gen 3 SiC MOSFETs

H-bridge topology

Compatible industry standard package for multiple sourcing

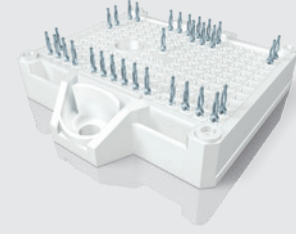

SEMITOP® E

8kW - 120kW

Flexible Pinout for Low-Inductance

Baseplate-less industry standard power module

Press-fit pins for solder-less connection to PCB

650V / 1200V IGBT: 10A to 200A

1200V SiC: 30A to 250A

3-level, H-bridge, half-bridge, Vienna and rectifier topologies

Optimized mounting concept and pre-applied High Performance Thermal Paste or High Performance Phase Change Material

Soft and fast switching 650V IGBT S5 and H5



Power Electronic **Stack Platforms** for **Fully Qualified** Inverter Assemblies Tailored to Your **Specific Needs**

Standard Stacks

Our Power Electronic Stacks enable our customers to succeed in dynamic markets and meet any global challenge. We deliver Rectifier-, IGBT- and SiC-based stacks for AC voltages from 380V to 690V. Our standard stacks cover a output current range from 70A to 4000A.

Water-Cooled IGBT Stacks

SEMISTACK RE
SEMIKUBE MLI

Air-Cooled IGBT Stacks

SEMIKUBE
SEMIKUBE SlimLine

Diode/Thyristor Stacks

SEMISTACK CLASSIC B6U/B6C/W3C

Customized Stacks

In addition to standard stacks, Semikron Danfoss has vast experience in developing customer-specific solutions. Engineers are available in our stack centers around the globe to offer such solutions by adapting existing platforms or designing customized converters.

Four Key Factors to Your Success

Shortest time to market

Cost savings in R&D, production and qualification

Global Semikron Danfoss stack production footprint

Highly experienced engineering team

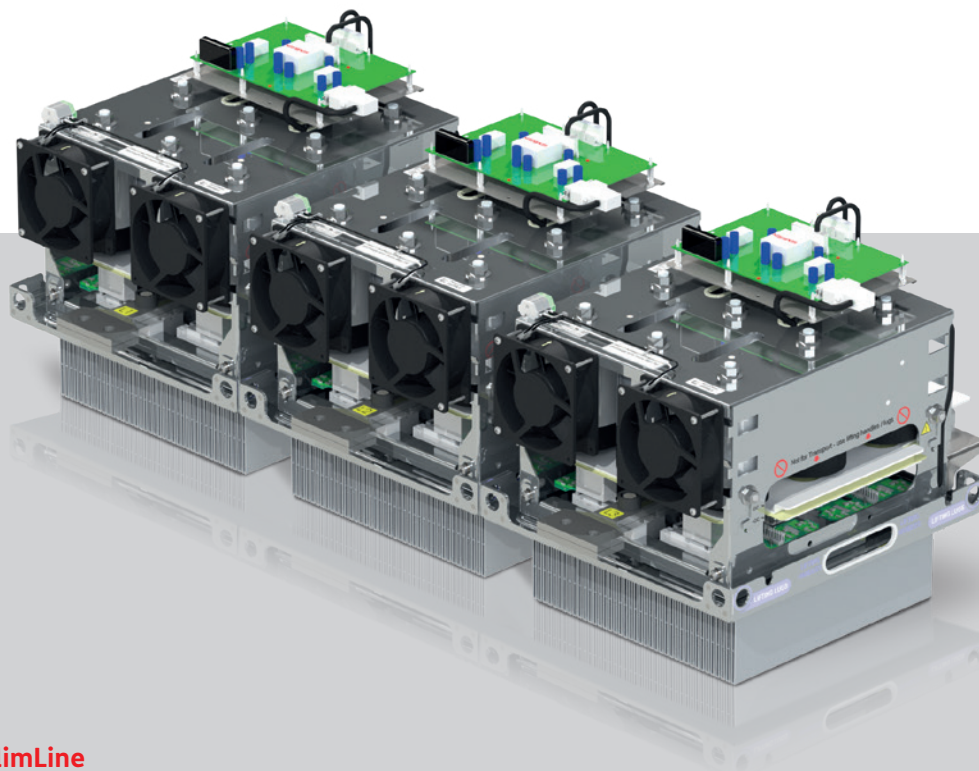

SEMIKUBE® SlimLine

Air-cooled IGBT Power Stack

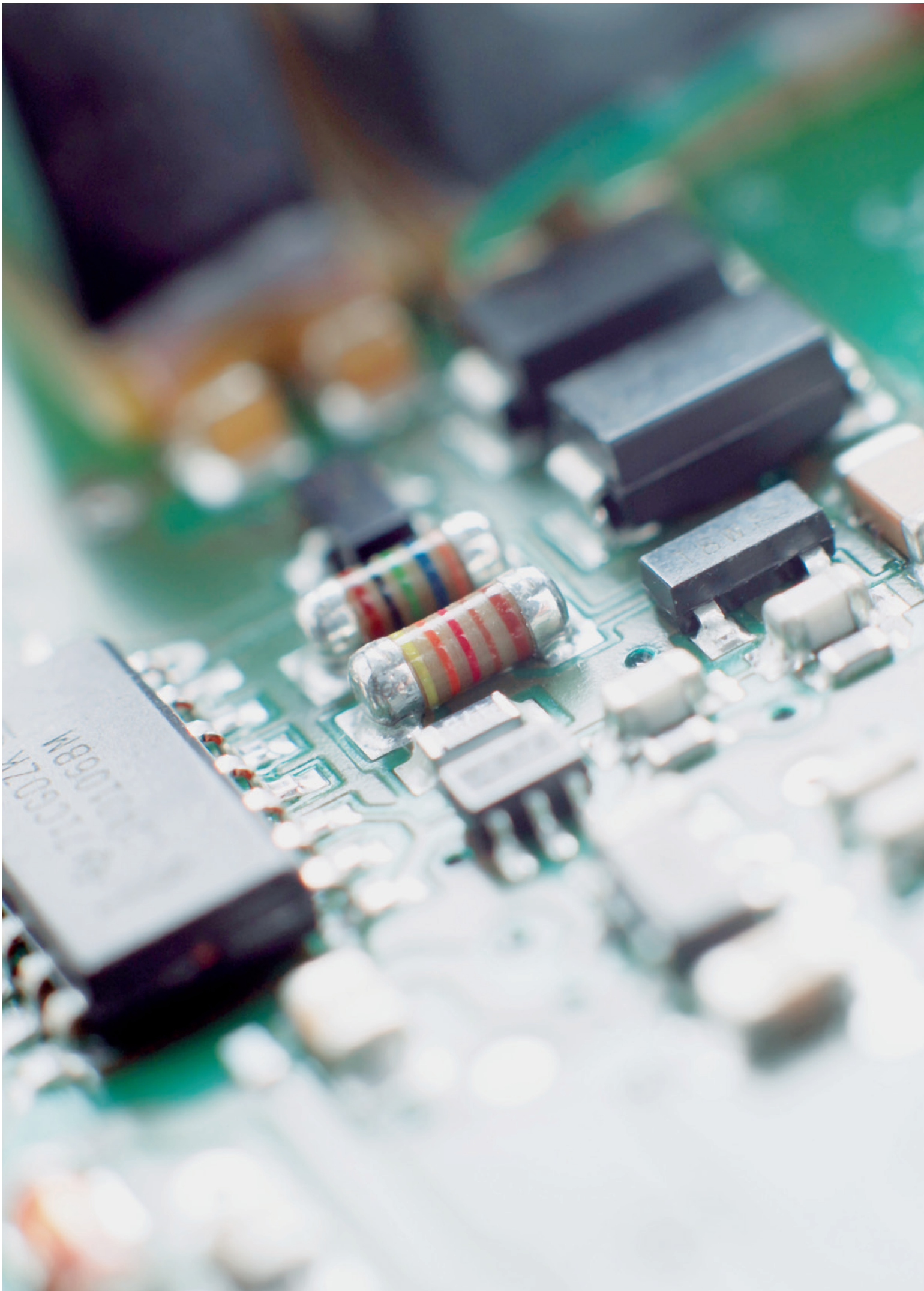

Product Portfolio

IGBT Driver

The unique product portfolio enables access to all established industries with a one-stop solution that combines state-of-the-art power modules and driver electronics.

Our IGBT drivers are available as two-channel driver cores suitable for any standard semiconductor power module or as Plug-and-Play solutions, which perfectly fit the SEMiX 3 Press-Fit, SEMITRANS 10 and compatible modules.

Cost Efficient

Achieve outstanding system compactness and create space- and cost-effective inverter designs with our drivers, utilizing highly integrated ASIC technology. Isolated DC-link voltage and temperature sensor signals at the driver's interface along with over-voltage and over-temperature lockout also help to reduce system costs significantly.

Time Efficient

More than 25 years of experience in developing innovative IGBT driver electronics enables Semikron Danfoss to have a short-term solution for almost every challenge related to driver electronics. Our Plug-and-Play drivers connect directly to most common standard IGBT modules. The IGBT driver cores fit with the adapter boards or application sample PCBs. For the latter, Semikron Danfoss shares the entire manufacturing data to decrease development time, speeding up the time-to-market.

Reliable

Our SKYPER are well-known, highly robust and reliable IGBT driver solutions under demanding environmental conditions. Over many years of field operation experience the proprietary IGBT driver technology has been relentlessly developed further. This technology sets new standards for the essential features of safe gate control, reliable gate protection and reinforced insulation.

Compact Design

Our SKIC ASIC technology enables very compact system design with minimal peripheral components. With highly integrated signal processing and multi-channel failure management, our ASICs offer robust gate control



Key Factors

Reinforced insulation for signal and power transmission

Two-channel driver

Up to 1700V transients

Up to 1500V continuous DC bus voltage

8Apk to 35Apk per channel

1W to 4.2W peak per channel

Suitable for multi-level topologies and Generation 7 IGBT

SKYPER 12 PV

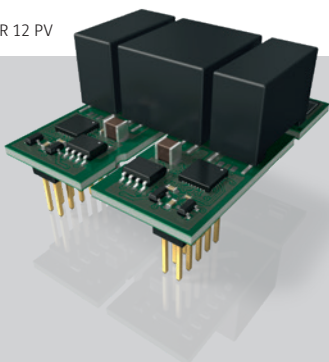

Driver Cores

Two-channel driver cores for PCB integration with Semikron Danfoss ASIC technology and integrated safety functions

SKYPER 12 Press-fit



Plug-and-Play Driver

Two-channel drivers for direct module mounting with electrical or optical interface

SKYPER 42 LJ PV

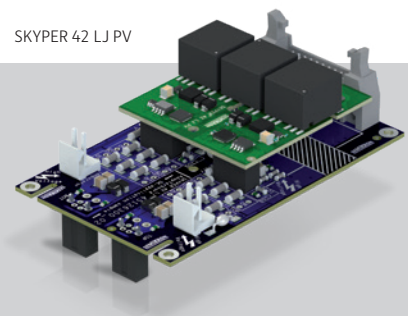

Adapter Board and Application Samples

Adapter boards for driver core mounting to Semikron Danfoss IGBT and SiC modules



Thermal Interface Materials

Stay Cool: Heat Dissipation is Our Job

Semikron Danfoss was the first power module manufacturer on the market to offer power modules with pre-applied thermal interface material (TIM). We now have over two decades of experience and more than 30 million pre-printed modules in the field.

We design print patterns for each module type for the best TIM distribution and thickness when the module is mounted to a heatsink. These patterns are printed on the modules in a clean environment on an automated silkscreen and stencil printing line. Statistical process control (SPC) is used to guarantee consistency. Special packaging is implemented to ensure that the TIM arrives at your production line in pristine condition.

Semikron Danfoss offers either thermal grease or phase change material depending on customer requirements (e.g. performance increase, reduced handling effort) and module type (with or without baseplate). The reliable assembly of baseplate-less modules is aided by a low-viscosity material such as thermal paste. Our High Performance Thermal Paste (HPTP) achieves this and, with optimized filler content, provides best in class thermal performance.

Alternatively, for ease-of-handling during assembly, most power modules are also available with pre-applied phase change material (PCM). Phase change materials have a solid consistency at room temperature. With the application of heat during first operation, the PCM flows to fill gaps and provide a thermal interface. With HP-PCM, the new Semikron Danfoss-exclusive High

Performance Phase Change Material, we combine the benefits of a phase change material with the performance of the best available paste.

Key Features

- Module-specific patterns for optimized TIM distribution
- Simplified logistics and reduced production costs
- Improved assembly robustness
- Increased lifetime and reliability

Portfolio

HPTP: High Performance Thermal Paste

HP-PCM: High Performance Phase Change Material

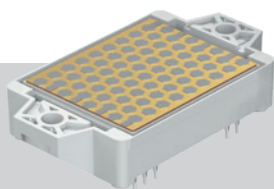
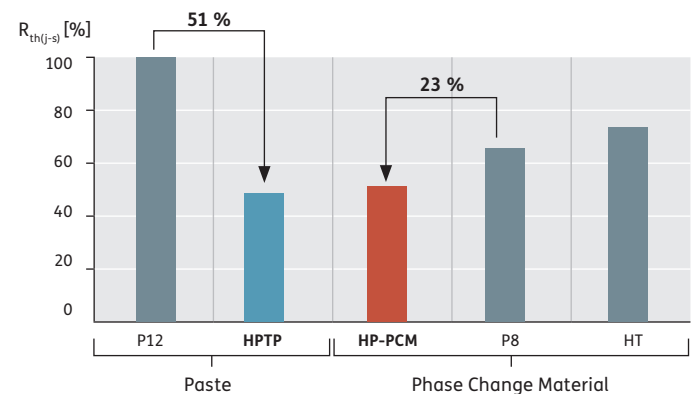

Baseplate-less module with pre-applied thermal paste

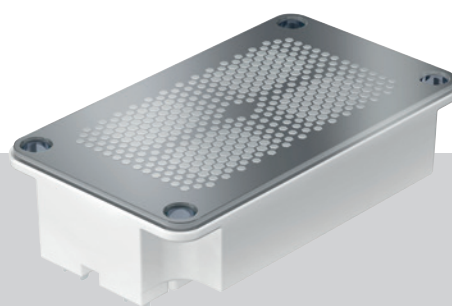

Baseplate module with pre-applied phase change material

THE ULTIMATE PARTNER IN POWER ELECTRONICS

Semikron Danfoss is a global technology leader in power electronics. Our product offerings include semiconductor devices, power modules, stacks and systems. In a world that is going electric, Semikron Danfoss technologies are more relevant than ever. With our innovative solutions for automotive, industrial and renewable applications we help the world utilize energy more efficiently and sustainably and thus to significantly reduce overall CO₂ emissions – facing one of the biggest challenges today. We take care of our employees and create value for our customers by investing significantly in innovation, technology, capacity, and service to deliver best-in-industry performance and for a sustainable future.



05/2024



Semikron Danfoss GmbH

Husumer Strasse 251
24941 Flensburg, Germany

Semikron Danfoss International GmbH

Sigmundstrasse 200
90431 Nuremberg, Germany

www.semikron-danfoss.com

Note: All information is based on our present knowledge and is to be used for information purposes only. The specifications of our products may not be considered as an assurance of component characteristics.

