



CATALOGO GENERALE | general catalogue

2020  



www.tvzassali.it





CATALOGO GENERALE general catalogue

2020  

UN IMPEGNO PRECISO

A CLEAR MISSION



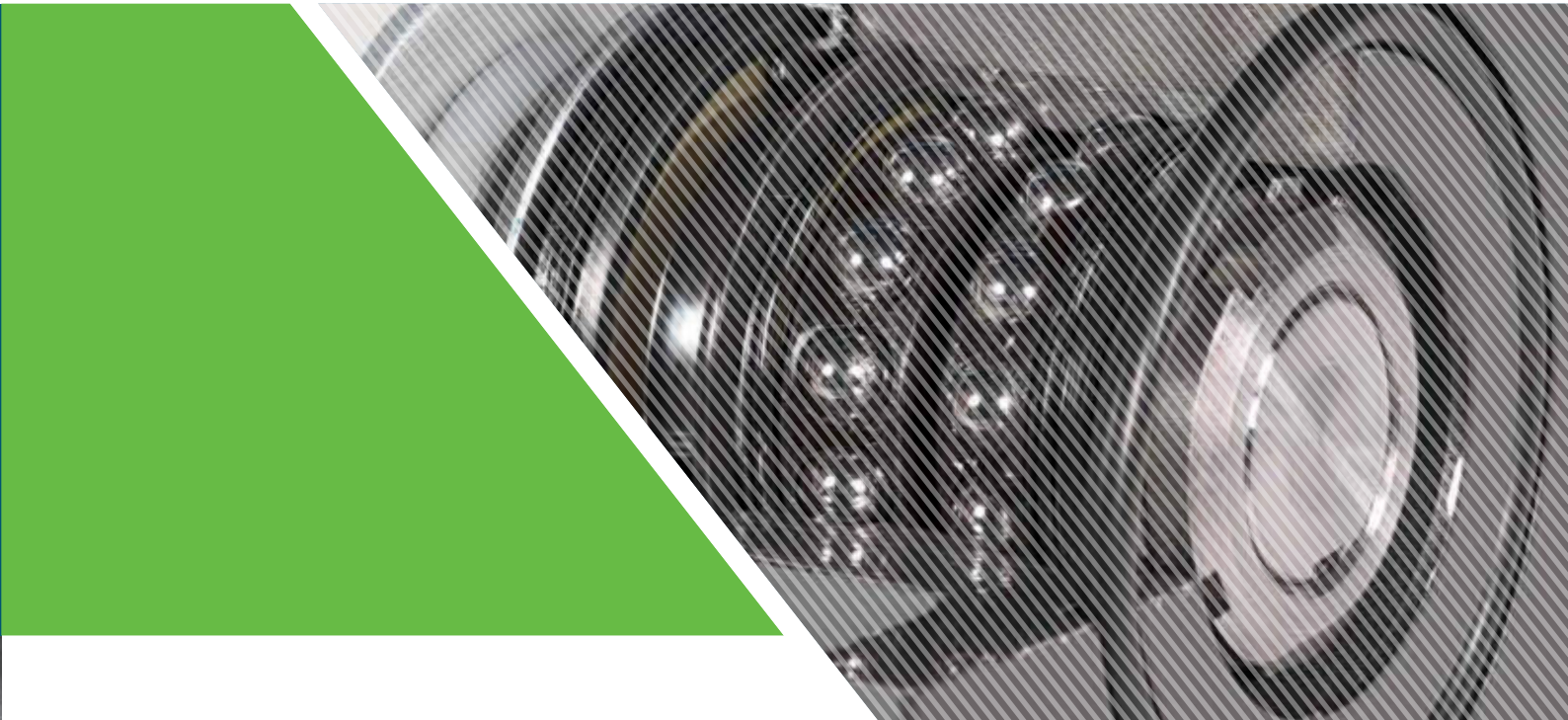

Essere i migliori specialisti "Made in Italy" negli assali e gruppi di sospensione

La produzione industriale è una sfida continua. Ora più che mai. Tenacia e voglia di guardare avanti si alternano a difficoltà che vanno affrontate e superate. Una volta bastava un punto di forza per fare un'azienda, oggi la propositività deve essere globale. Consapevoli di questo scenario, In TVZ siamo strutturati in modo da mantenere alta la qualità dell'offerta e allo stesso tempo sviluppare competitività al servizio dei nostri clienti. Crediamo che il miglioramento continuo dei processi aziendali sia fondamentale per essere e mantenersi i migliori specialisti Made in Italy nel nostro settore.

Be the best "Made in Italy" experts in axles and suspension groups

Industrial production is an ongoing challenge. Now more than ever. Tenacity and desire to look ahead alternate with difficulties that must be faced and overcome. Once it only took one single point of strength to make a company, nowadays a proactive approach must be taken. Aware of this scenario, TVZ is structured to maintain the high quality of its offer and at the same time develop the competitiveness of our customer service. We believe that continuous improvement of business processes is critical to be and remain the best Made in Italy specialists in our field.

MISSION

ENGINEERING

RISORSE DEDICATE COMMITTED ENGINEERING



Professionalità e know-how al servizio della tecnologia per macchine agricole e automotive industriale

Ricerca e sperimentazione sui materiali e sulle tecnologie rendono ogni prodotto TVZ un compagno di lavoro fedele e generoso, sia per l'impresa agricola sia per i diversi campi applicativi dell'automotive. L'impegno di engineering fa di TVZ un'azienda sempre aggiornata sulle nuove tendenze della meccanizzazione e fortemente reattiva alle evoluzioni dei mercati. Le nostre professionalità sono coordinate in progetti mirati a soddisfare le domanda per ciò che riguarda assi, semiassi e sospensioni. Soluzioni sempre conformi alle normative anche nel caso di proposte totalmente personalizzate.

Professionalism and know-how committed to agricultural machinery and industrial automotive

Research and testing on materials and technologies make each TVZ product a faithful and generous work companion, both for the farm and the different automotive fields. The engineering effort makes of TVZ an up-to-date company on new trends in mechanization and also highly responsive to market developments. Our professionalism are coordinated in projects designed to meet the demand for what concerns axles, stub axles and suspensions, always offering solutions which comply with regulations even in the case of personalized products.

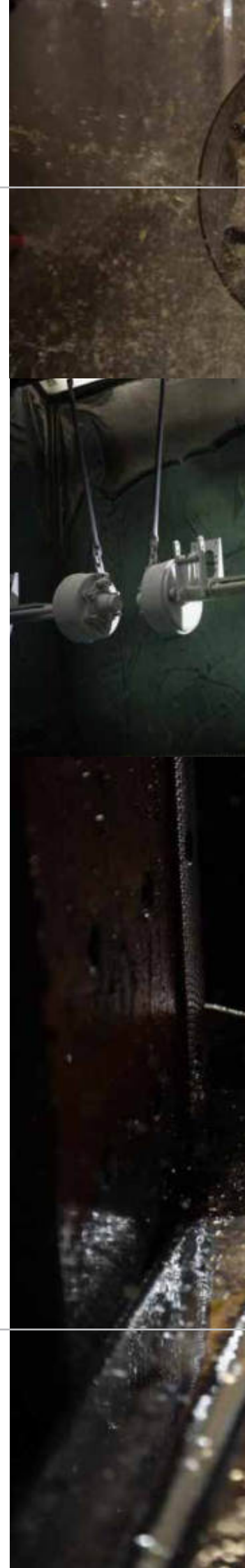



PRODUZIONE

PRODUCTION

STABILIMENTI ALL'AVANGUARDIA

Linee di produzione costantemente aggiornate per unire grandi numeri e alta qualità

TVZ opera con un layout di fabbrica molto efficiente e versatile, strutturato su principi di smart manufacturing. In particolare la flessibilità ci consente di lavorare con clienti di ogni dimensione e coprire esigenze anche molto diversificate, assicurando sempre quel dialogo collaborativo che è riconosciuto come principale punto di forza dell'azienda. Le certificazioni che attestano la competenza e i livelli di eccellenza dell'attività TVZ vengono costantemente aggiornate e implementate in collaborazione con gli organismi internazionali e gli enti accreditati.

STATE-OF-THE-ART FACTORY

Constantly updated production lines to combine large numbers and high quality

TVZ operates based on a very efficient and versatile factory layout, structured on the principles of smart manufacturing. In particular, flexibility allows us to work with companies of all sizes and respond to diversified requirements, always ensuring that collaborative dialogue that is recognized as the main point of strength of the company. Certifications attesting to the competence and the levels of excellence of TVZ are constantly updated and implemented in collaboration with international organizations and accredited institutions.



PRESENTAZIONE DEL CATALOGO

Per semplificare la scelta dell'assale più adatto all'utilizzatore, TVZ srl è lieta di proporre il proprio catalogo di prodotti, dove si possono trovare: assali fissi con e senza freno, assali sterzanti con e senza freno, sospensioni meccaniche singole, tandem e tridem e sospensioni pendolari di tipo bogie.

USO CORRETTO DEL CATALOGO

La portata di un assale è data dalla resistenza della trave e dei cuscinetti. La resistenza della trave è influenzata dal carico sull'assale, dallo sbalzo applicato e dalla velocità di utilizzo. La resistenza dei cuscinetti è influenzata dal carico sull'assale, dalla velocità, dallo spostamento della ruota, dalle dimensioni e dal tipo di pneumatico e dalla configurazione di montaggio degli assali sul veicolo. Non sempre tutti questi fattori vengono presi in considerazione per la scelta dell'assale.

Per un uso corretto del catalogo è bene seguire quanto riportato di seguito:

Come scegliere l'assale

Per individuare l'assale corretto, è bene partire utilizzando le tabelle da pag. 25 a pag. 39, con le quali, in base al carico, lo sbalzo, la configurazione, la velocità ed il tipo di trave è possibile identificare la struttura portante per il nostro assale.

I carichi indicati nelle tabelle relative alle portate sono quelli massimi ammissibili per la velocità, lo sbalzo e l'applicazione indicata. Inoltre fanno riferimento all'utilizzo di ruote con flangia centrale (offset = 0) e con pneumatico avente il raggio dinamico minore o uguale a 400 mm per le tipologie di mozzi fino a 661 e 600 mm per le tipologie di mozzi superiori. Per l'utilizzo di ruote con spostamenti diversi da zero o raggi dinamici superiori ai 600 mm, prego contattare il nostro ufficio tecnico, che potrà consigliarvi in merito. Una volta scelto l'assale in base alla portata si deve verificare che anche lo sbalzo riferito sia sufficiente, lo sbalzo è la misura dal centro del pneumatico al centro della piastra di fissaggio dell'assale al telaio/sospensione (quota H). Per fare questa verifica è sufficiente utilizzare la formula riportata e spiegata prima delle tabelle delle portate a pagina 24. Nel caso gli assali vadano ad equipaggiare un veicolo con gli assi ravvicinati tra di loro, TVZ consiglia l'utilizzo di un assale autosterzante (veicolo tandem) o due assali autosterzanti (veicolo tridem), questo per ridurre in maniera significativa la forza assiale che verrebbe a generarsi per lo strascinarsi dei pneumatici sul terreno durante una curva, tali forze vanno a sovraccaricare i cuscinetti riducendone la vita, e provocano un'usura precoce del pneumatico, che rappresenta una delle spese maggiori di manutenzione di un veicolo.

Attacchi

Una volta scelto il tipo di assale, verificare quali siano gli attacchi disponibili, tenendo presente che non tutte le tipologie di attacco sono disponibili in versione gemellata, è possibile verificare tali disponibilità consultando la tabella a pagina 20 del presente catalogo.

Per un corretto serraggio della ruota al mozzo consultare la tabella a pagina 21 riportante le coppie di serraggio da applicare ai dadi, onde evitare il danneggiamento della colonnetta e/o del dado.

Freni

Il freno va scelto in base al peso della macchina e dal tipo di pneumatico utilizzato, bisogna anche tenere conto che lo stesso freno in nazioni diverse può avere capacità di carico diverse, definite in base alle efficienze minime richieste dai vari enti omologatori. Le capacità di frenatura indicate in questo catalogo da pag. 12 a pag. 15 sono relative all'uso in Europa fino ad alta velocità (2015-68 e ECE-R13), in Germania a 40 km/h (Tuev – StVZO) e in Francia a 25 km/h (UTAC – NF U16-051).

Un'altra cosa importante da verificare è la possibilità di alloggiare il freno all'interno della ruota, per controllare quale è la ruota minima utilizzabile in base al freno, visionare la tabella a pagina 17 del presente catalogo.

Verificare infine che sia possibile accoppiare il freno con il tipo di assale scelto utilizzando la tabella a pagina 16.

Nel caso si debba dimensionare l'assale come primo esemplare, da omologare quindi, contattare il nostro ufficio tecnico in anticipo rispetto all'omologa, in modo da poter definire correttamente e per tempo l'assale (trave – cuscinetti – freno e attacco) e le procedure di rodaggio necessarie.

Si raccomanda, di eseguire un buon rodaggio ai freni prima di effettuare una prova di collaudo.

Opzioni

È possibile equipaggiare gli assali TVZ con:

- bilancini per poter azionare i due freni con un solo cilindro;
- piastre forate per il montaggio di Brake Chamber, con forature per cilindri da 12" a 36";
- cilindri freno idraulici con o senza molle di richiamo.

È possibile realizzare sugli assali TVZ:

- verniciatura antiruggine di fondo;
- verniciature fondo + finitura;
- cavallino.

RICERCA

La ricerca e la sperimentazione sui materiali e il costante aggiornamento dei processi produttivi fa di ogni prodotto TVZ un compagno di lavoro fedele e generoso sia per l'agricoltore che per il trasportatore.

Con personale interno, o appoggiandosi a laboratori specializzati, vengono affrontati tutti gli aspetti della qualità e della sicurezza dei prodotti: dalle prove sui materiali, al controllo sistematico delle lavorazioni meccaniche, alla sorveglianza sulle fasi di assemblaggio e verniciatura, fino al collaudo dei freni al banco, in collaborazione con centri prova sia Italiani che esteri.

TVZ srl declina ogni responsabilità per eventuali inesattezze e si riserva il diritto di apportare delle modifiche al presente catalogo.

CATALOGUE PRESENTATION



In order to simplify the process of choosing the most suitable axle for the user, TVZ Srl is pleased to recommend the catalogue of its own products with the following products available: fixed axles with or without brakes, steering axles with or without brakes, single, tandem, tridem mechanical suspensions and bogie pendular suspension systems.

USING THE CATALOGUE CORRECTLY

The capacity of an axle is given by the resistance of beams and bearings. Beam resistance is affected by the axle load, the overhang applied and the operation speed. Bearing resistance is affected by the axle load, speed, wheel offset, dimensions and type of tyre and by the axle assembly configuration on the vehicle. All these factors are not always taken into account when choosing the axle.

In order to use the catalogue correctly, follow the indications below:

How to choose the axle

To identify the correct axle, start by using the tables on pages 25 to 39. It is possible to identify the bearing structure for our axle according to loading, overhang, configuration, speed and the type of beams.

The load capacities specified in the tables are the maximum allowed for speed, overhang and indicated application. Additionally the table refers to the use of wheels with central flange (offset = 0) and with tyres having a dynamic radius smaller than or equal to 400 mm for hubs types up to 661 and 600 mm for higher hubs types.

Please contact our technical department for advice regarding the use of wheels with offset different from zero or a dynamic radius greater than 600 mm. Once the axle is chosen according to the capacity, check if the specified overhang is sufficient; the overhang is the distance between the tyre centre and the centre of the plate fixing the axle to the frame/suspension (position H). To carry out this check, it is sufficient to use the formula indicated and described before and the capacity tables on page 24. If axles are fitted to a vehicle with axles that are close to each other, TVZ recommends using a self-steering axle (tandem vehicle) or two self-steering axles (tridem vehicle), in order to considerably reduce the axial force generated by the tyre dragging on the surface while on a bend. Such force overloads the bearings reducing life and causing premature wear of the tyre, which is one of the most significant costs in vehicle maintenance.

Fittings

Once the type of axle is chosen, check for the available fittings, taking into account that not all types of fittings are available in the twinned version. The availability can be verified consulting page 20 of this catalogue.

To correctly tighten the wheel to the hub, please consult the table on page 21 indicating the tightening torques to be applied to nuts, in order to avoid damaging the stud bolt and/or the nut.

Brakes

Brakes are chosen according to the vehicle weight and type of tyre used; in addition, it is necessary to consider that the same type of brake can have different loading capacities depending on the nation. Loading capacity is defined according to the minimum efficiency required by the different approving authorities. The braking capacity indicated from page 12 at page 14 are related to the use in Europe until at high speed (2015-68 and ECE-R13), in Germany at 40 km / h (Tuv - StVZO), and in France at 25 km / h (UTAC - NF U16-051). It is also important to verify that the brake can be housed inside the wheel. To check which is the smallest wheel that can be used according to the brake, please consult the table on page 17 of this catalogue. Finally, check if the brake fits to the chosen axle by consulting the table on page 16. If the axle must be adjusted as a first model to be type-approved, please contact our technical department in advance about type-approval in order to correctly and timely establish both the axle features (beams – bearings – brake and connection) and the necessary testing procedures.

We recommend that you carry out a good brake testing before performing an acceptance test.

Options

It is possible to equip TVZ axles with the following components:

- compensator in order to activate brakes by means of only one cylinder;
- drilled plates to assemble the Brake Chamber, with drilling holes for cylinders from 12" to 36";
- hydraulic brake cylinders with or without return springs.

The TVZ axles can undergo the following treatments:

- priming rust preventer painting;
- priming painting + finish;
- camber.

RESEARCH

Material research and testing and the constant update of production processes makes each TVZ product a faithful and helpful workmate for both farmers and for transporters.

With internal personnel or with the help of specialised workshops, the quality and safety of the products are verified: from material tests, systematic control of mechanical machining operations, supervision during the assembly and painting phases up to brake bench tests performed in collaboration with Italian and foreign testing centres.

TVZ Srl is not liable for any inaccuracies and reserves the right to modify this catalogue.



INDICE

INDEX

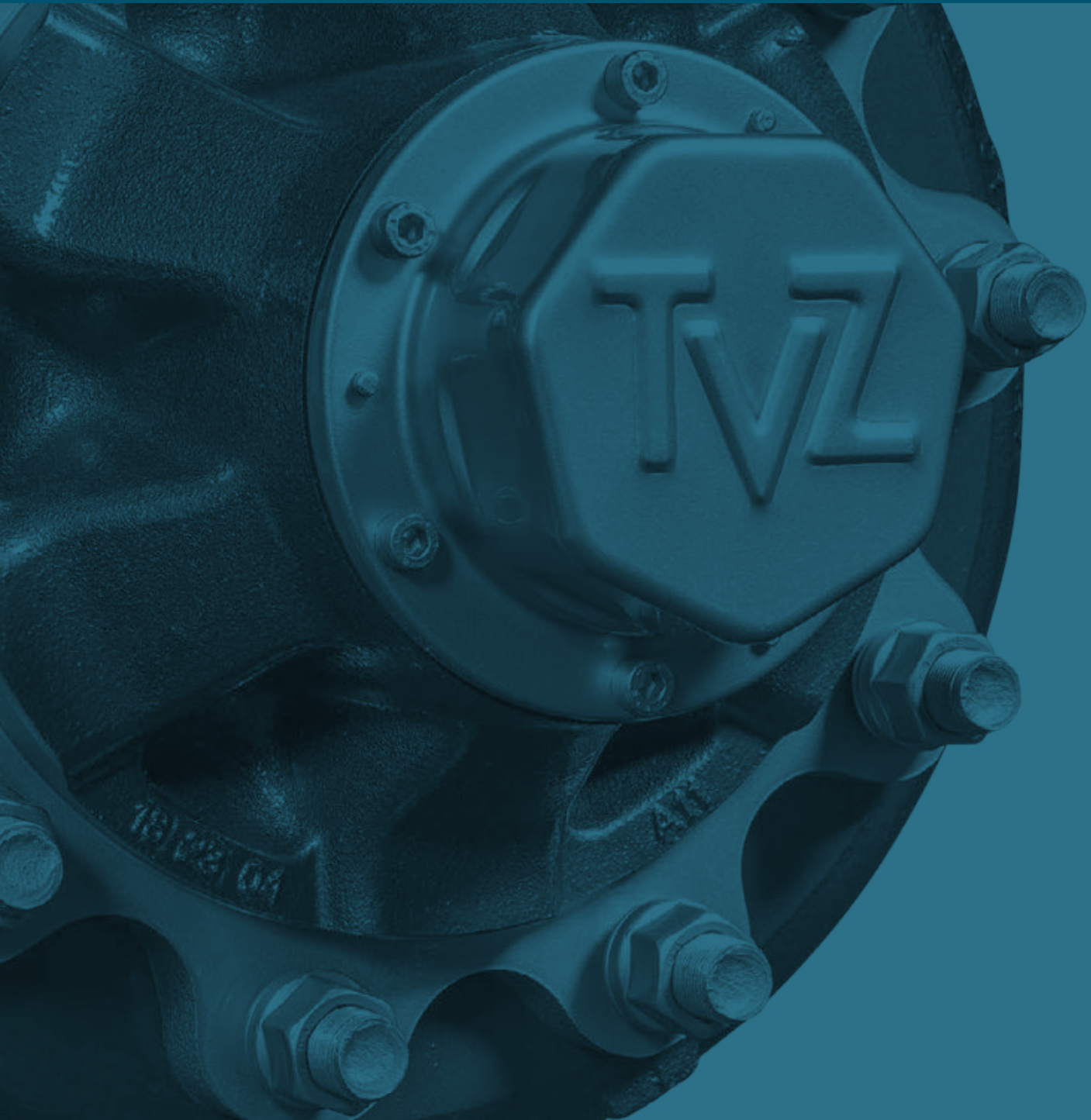



■ FRENI _ BRAKES	11
Freni omologati _ Approved brakes	12
Cilindri omologati _ Approved cylinders	14
Freni ad inerzia _ Inertia brakes	15
Freni ad azionamento idraulico _ Hydraulic brakes	15
Accoppiamento freni/quadri _ Connection brakes/beams	16
Caratteristiche indicative dei freni _ Indicative characteristics of the brakes	17
■ ATTACCHI _ FITTINGS	19
Attacchi _ Fittings	20
Coppie di serraggio _ Torque	21
■ ASSALI _ AXLES	23
Assali e semiassi _ Axles and stub axles	24
Assali quadri _ Square axles 25/40 km/h - 60/80 km/h	25
Semiassi quadri _ Square stub axles 25/40 km/h - 60/80 km/h	27
Semiassi tondi _ Round stub axle 25/40 km/h	29
Semiassi sterzanti _ Steering stub axles	30
Semiassi ribassati _ Offset stub axles	31
Semiassi per dischi frangizolle _ Stub axles for disk roller scrapers	31
Assali sterzanti _ Steering axles	32
Assali sterzanti comandati _ Forced steering axles	37
Accessori _ Optional	40
■ SOSPENSIONI _ SUSPENSIONS	43
Sospensioni bogie _ Bogie suspensions	44
Supporti centrali _ Central supports	45
Sospensioni bogie _ Bogie suspensions	46
Cavallotti _ U-bolts	52
Coppie di serraggio _ Torque	52
Sospensioni meccaniche _ Mechanical suspensions	54
Coppie di serraggio _ Torque	55
Balestre _ Springs	55
Sospensioni meccaniche agricole _ Agricultural mechanical suspensions	56
Sospensioni meccaniche industriali _ Industrial mechanical suspensions	62
Sospensioni pneumatiche _ Pneumatic suspensions	78



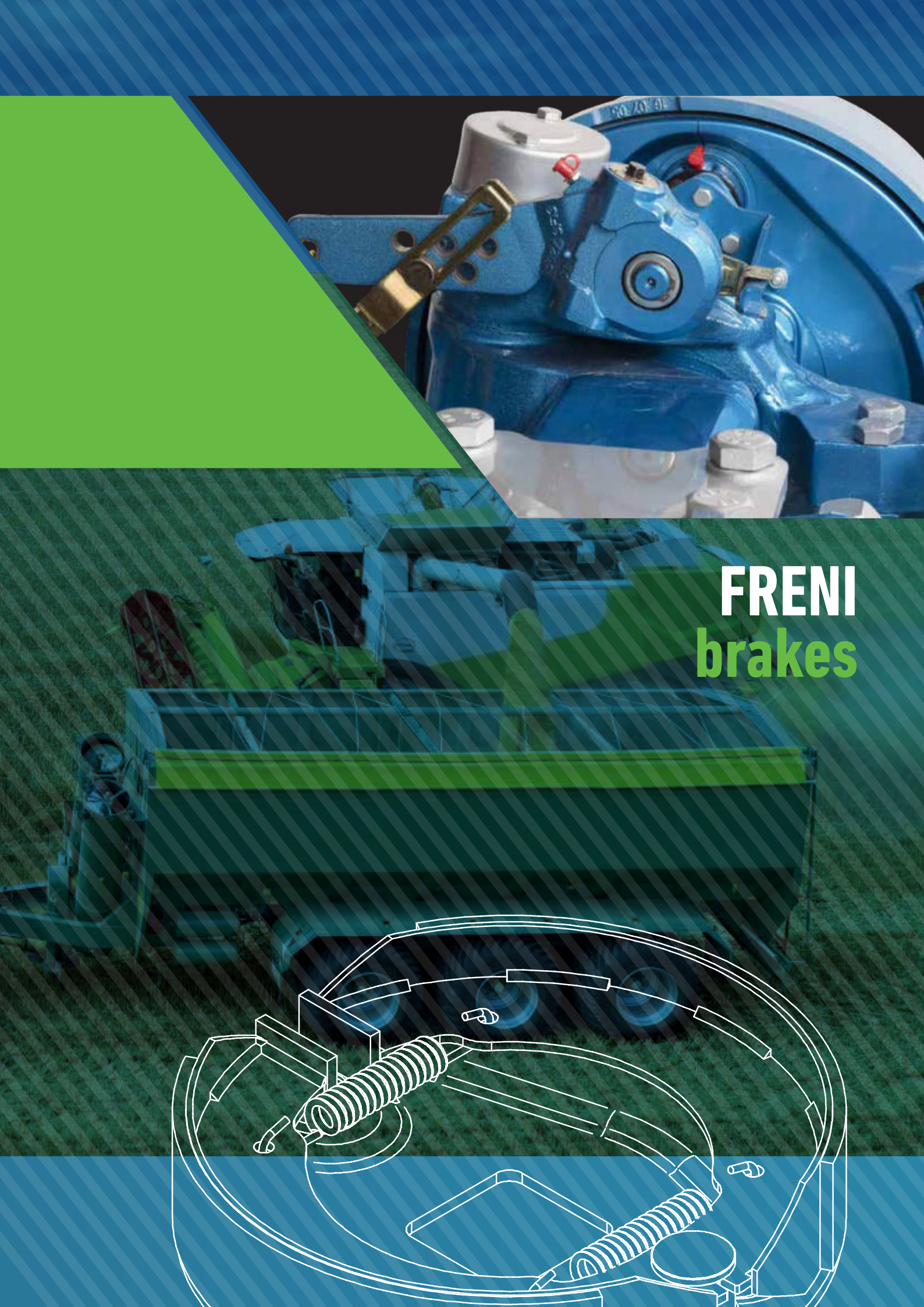

FRENI brakes

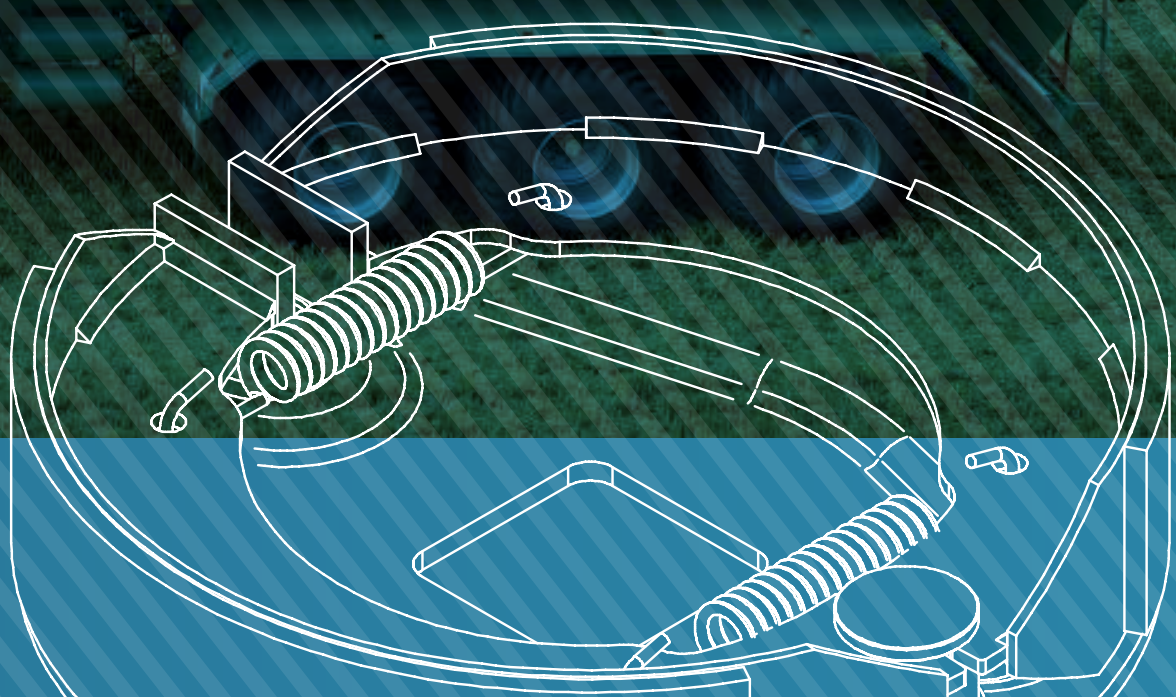



Freni omologhe europee 2015/68 _ European approved brakes 2015/68



VELOCITÀ - Speed 30 km/h								
TIPO Type	DIMENSIONI Dimensions	OMOLOGA Approval	RAGGIO DI PROVA Test radius (mm)	ID1	ID2	ID3	ID4	GUARNIZIONE Lining
25M	250x060	2015/68	336	A25M	25M	3924	36101718	EUR 0112
30M	300x060	2015/68	406	A30M	30M	4905	36105818	EUR 0112
30G	300x060	2015/68	406	A30G	30G	5886	36101618	EUR 0112
30S	300x090	2015/68	418	A30S	30S	7848	36101517	EUR 0112
9I	300x090 idr.	2015/68	418	A9I	9I	6867	36101819	EUR 0112
314I	300x135	2015/68	383	KF	314I	9810	scheduled	EUR 0112
35G	350x060	2015/68	450	A35G	35G	6867	36104118	EUR 0112
35S	350x080	2015/68	450	A35S	35S	8829	36101919	B1517
40G	400x080	2015/68	550	A40G	40G	7848	36102218	EUR 0112
406I	406x120	2015/68		A406I	406I		scheduled	EUR 1106
VELOCITÀ - Speed 40 km/h								
TIPO Type	DIMENSIONI Dimensions	OMOLOGA Approval	RAGGIO DI PROVA Test radius (mm)	ID1	ID2	ID3	ID4	GUARNIZIONE Lining
25M	250x060	2015/68	305	A25M	25M	3198	36107516	EUR 0112
30G	300x060	2015/68	397	A30G	30G	3581	36107616	EUR 0112
30S	300x090	2015/68	418	A30S	30S	5396	36108216	EUR 0112
9I	300x090 idr.	2015/68	418	A9I	9I	5396	36101719	EUR 0112
310I	300x100	2015/68	419	JF	310I	6867	36107518	EUR 0112
35G	350x060	2015/68	450	A35G	35G	5886	36105317	EUR 0112
35S	350x080	2015/68	450	A35S	35S	6377	36105918	B1517
40G	400x080	2015/68	525	A40G	40G	7358	36102019	EUR 0112
406I	406x120	2015/68	560	A406I	406I	9810	36108116	EUR 1106
406P	406x140	2015/68	560	A406P	406P	12262	36103818	EUR 1106

I valori indicati per le omologhe "pianificate" possono variare - The value of the "scheduled" homologations could vary

Freni omologhe europee ECE-R13 _ European approved brakes ECE-R13



VELOCITÀ - Speed 105 km/h								
TIPO Type	DIMENSIONI Dimensions	OMOLOGA Approval	RAGGIO DI PROVA Test radius (mm)	ID1	ID2	ID3	ID4	GUARNIZIONE Lining
310I	300x100	ECE-R13	420	JF	310I	5886	36100513	EUR 0112
314I	300x135	ECE-R13	383	KF	314I	7848	36100413	EUR 0112
316I	300x160	ECE-R13	388	A316I	316I	9812	36106317	EUR 0112
406I	406x120	ECE-R13	560	A406I	406I	8829	36104413	EUR 1106
406P	406x140	ECE-R13	560	A406P	406P	10791	36104513	EUR 1106
420I	420x180	ECE-R13	560	A420I	420I	12753	36104215	EUR 0112



TIPO Type	DIMENSIONI Dimensions	CAPACITÀ PER FRENO Capacity for brake (kg)	PNEUMATICO Tyre		FATTORE DI FRENATURA Brake factor (Kennwert)	RIFERIMENTO OMOLOGA Approval reference	GUARNIZIONE Lining
		VELOCITÀ - Speed ≤ 40 km/h	R.min. (mm)	R.max. (mm)			
25M	250x60	1800	270		0,92	361-007-08	B.1117
		1275		380			
30M	300x60	2420	330		1,16	361-009-08	B.1117
		1700		470			
30S	300x90	3210	350		1,22	361-003-08	B.1117
		2045		550			
310I	300x100	4500	350		1,52	361-040-15	EUR 0112
		2760		570			
314I	300x135	5240	350		1,49	361-041-15	EUR 0112
		3220		570			
35G	350x60	3210	350		1,22	361-005-08	B.1117
		2045		550			
35S	350x80	4285	350		1,23	361-040-10	B.1117
		2725		550			
40G	400x80	3750	420		1,20	361-011-08	B.1117
		2460		640			
406I	406x120	6480	430		1,30	361-015-15	EUR 1106
		3770		740			
406P	406x140	5920	520		1,72	361-043-13	EUR 1106
		3710		830			
420I	420x180	7260	520		1,20	361-043-15	EUR 0112
		4550		830			
9I	300x90 idr.	3600	350		n.n.	361-044-16	EUR 0112
		2300		550			





Freni omologati UTAC _ UTAC approved brakes

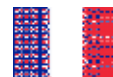

FRENATURA CON AZIONAMENTO IDRAULICO VELOCITÀ 25 km/h - Hydraulic braking system speed 25 km/h							
TIPO Type	DIMENSIONI Dimensions	CAPACITÀ PER FRENO Capacity for brake [kg]	PNEUMATICO Tyre		COPPIA ALLA CAMMA Cam shaft torque [Nm]	RIFERIMENTO OMOLOGA Approval reference	GUARNIZIONE Lining
			R.min (mm)	R.max (mm)			
25M	250x60	2753	350		465	13/08703	B.1117
		2140		450			
30M	300x60	3415	350		520	13/08702-1	B.1117
		2650		450			
30S	300x90	7055	350		930	13/08704-1	B.1117
		4490		550			
314I	300x135	12593	350		930	13/09282	EUR 0112
		8815		500			
35G	350x60	7485	350		630	13/06578-1	B.1117
		4365		600			
35S	350x80	8950	350		730	13/06579-2	B.1117
		5220		600			
40G	400x80	8355	420		1130	13/09281	B.1117
		4280		820			
406I	406x120	17920	400		1330	13/09283	EUR 1106
		8434		850			
FRENATURA CON AZIONAMENTO PNEUMATICO VELOCITÀ 25 km/h - Pneumatic braking system speed 25 km/h							
TIPO Type	DIMENSIONI Dimensions	CAPACITÀ PER FRENO Capacity for brake [kg]	PNEUMATICO Tyre		COPPIA ALLA CAMMA Cam shaft torque [Nm]	RIFERIMENTO OMOLOGA Approval reference	GUARNIZIONE Lining
			R.min (mm)	R.max (mm)			
25M	250x60	3445	350		560	13/08703	B.1117
		2680		450			
30M	300x60	4253	350		630	13/08702-1	B.1117
		3308		450			
30S	300x90	8975	350		1130	13/08704-1	B.1117
		5710		550			
314I	300x135	13605	350		1130	13/09282	EUR 0112
		9523		500			
35G	350x60	8855	350		770	13/06578-1	B.1117
		5165		600			
35S	350x80	10603	350		890	13/06579-2	B.1117
		6185		600			
40G	400x80	10553	420		1380	13/09281	B.1117
		5405		820			
406I	406x120	20565	400		1625	13/09283	EUR 1106
		9678		850			

Cilindri omologati NF U16-051 _ NF U16-051 approved Cylinders

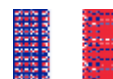

CILINDRI IDRAULICI - Hydraulic Cylinders						
TIPO Type	CORSA Stroke [mm]	FORZA A 100 BAR A CORSO NULLA Force at 100 bar with stroke null [N]	FORZA A 100 BAR A CORSO MAX. Force at 100 bar with stroke max. [N]	FORZA A 150 BAR A CORSO NULLA Force at 150 bar with stroke null [N]	RIFERIMENTO OMOLOGA Approval reference	NOTE
Ø20	108	2370	1743	3765	17333	CON MOLLE ESTERNE With external springs
Ø25	78	4319	3642	6568	17330	CON MOLLA INTERNA With internal spring
Ø30	110	6024	5189	9305	17331	CON MOLLE ESTERNE With external springs
Ø35	110	7866	7216	12178	17332	CON MOLLE ESTERNE With external springs



Freni ad inerzia _ Inertia brakes

Il nuovo regolamento per le macchine agricole ammette la frenatura ad inerzia per i rimorchi con massa fino a 8 ton e velocità fino a 40 km/h, estendendo così all'intero continente una tecnologia ben nota in Germania.

The new European regulation on agricultural admits the inertia braking for trailers with a mass of up to 8 tons and a maximum speed of 40 km/h, so extending to the whole continent the braking technology well known in Germany.

Timoni disponibili anche senza piastra posteriore, con occhio cuna o din - drawbars available also without rear plate with towing eye cuna or din

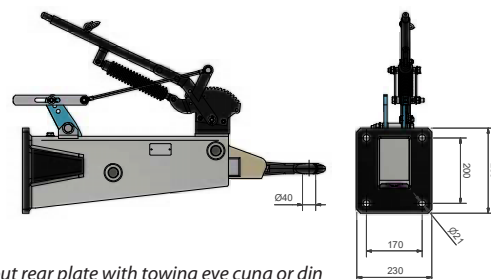

TIMONI Drawbars	TIPO Type	MASSA MINIMA Minimum mass (kg)	MASSA MASSIMA Maximum mass (kg)	CARICO VERTICALE Vertical load (kg)	CORSA EFFICACE Useful stroke (mm)
6 ton	TRM06	3500	6000	1000	120
8 ton	TRM08	5000	8000	1600	120

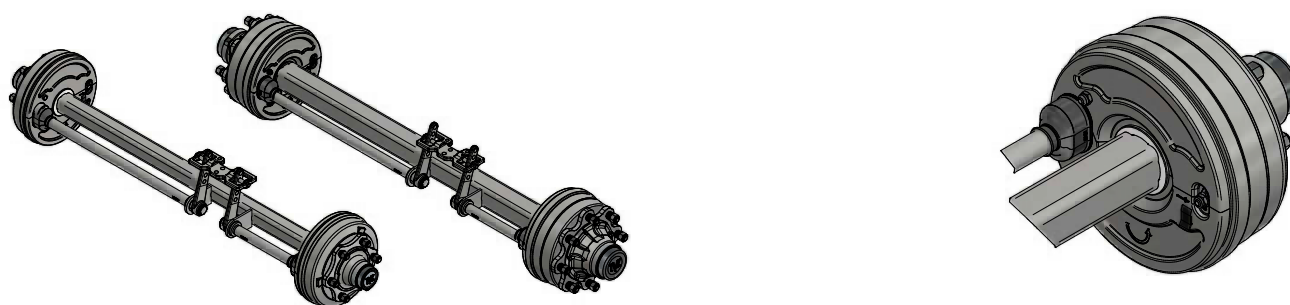

TIPO Type	DIMENSIONI Dimensions	VELOCITÀ Speed (km/h)	MASSA FRENATA Braking mass (kg/axle)	RAGGIO PNEUMATICO - Tire radius	
				Min (mm)	Max (mm)
6R	300x60	25	6000	480	480
6R	300x60	40	4000	340	480
9T	300x90	30	8000	400	482
9T	300x90	30	6000	340	480
9T	300x90	30	5000	500	610
9T	300x90	40	6000	340	480
9T	300x90	40	5000	500	610

Omologazioni pianificate - homologations scheduled

I valori indicati per le omologhe "pianificate" possono variare - The value of the "scheduled" homologations could vary

Freni ad azionamento idraulico _ Hydraulic brakes

Tra i freni proposti è disponibile anche una gamma con frenatura idraulica integrata nel tamburo. Le taglie disponibili sono 300x60 - 6Y (disponibile a breve) e 300x90 - 9I, con omologhe Mother Regulation a 30 km/h e 40 km/h.

Il vantaggio di un freno idraulico è che può essere montato agevolmente in tutte quelle macchine dove non c'è spazio per l'attuatore fissato alla leva del freno, come ad esempio atomizzatori, rotopresse, etc. Per sfruttare al massimo la capacità frenante è necessario montare un convertitore aria-olio, che può essere alloggiato in qualsiasi punto del veicolo, in questo caso l'impianto principale è ad aria. A differenza di altri freni del genere presenti sul mercato, i freni idraulici TVZ sono dotati di un registro manuale dell'usura, caratteristica che ne ha permesso l'omologazione Mother Regulation.

Among the proposed brakes there is also a range with hydraulic braking integrated in the drum. The available sizes are 300x60 - 6Y (available shortly) and 300x90 - 9I, with Mother Regulation homologation at 30 km/h and 40 km/h.

The advantage of a hydraulic brake is that it can be easily mounted in all those machines where there is no space for the actuator fixed to the brake lever, such as atomizers, round balers, etc. To make the most of the braking capacity it is necessary to install an air-oil converter, which can be housed anywhere in the vehicle, in this case the main system is air-powered.

Unlike other brakes of this kind on the market, the TVZ hydraulic brakes are equipped with a manual wear register, a feature that allowed the Mother Regulation approval.

Con i freni idraulici usare olio minerale - With hydraulic brakes use mineral oil

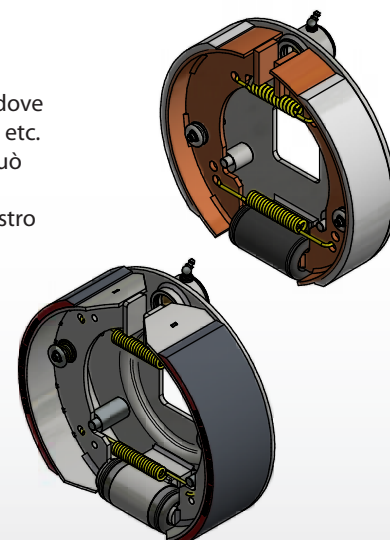



Accoppiamento freni-quadri _ Connection brakes-beams

TIPI DI FRENO Type of brake	BILLETTA - Beam															
	Q030	Q035	Q040	Q045	Q050	Q055	Q060	Q070	Q080	Q090	Q100	Q110	Q120	Q130	Q150	Ø127
140X30 - 140	X	X	X													
200X40 - 20M			X	X	X											
200X60 - 22M					X	X	X									
250X60 - 25M					X	X	X	X								
300X60 - 30M					X	X	X	X	X							
300X60 - 30G					X	X	X	X	X	X						
300X60 - 6R							X	X	X							
300X60 - 6Y					X	X	X	X	X							
300X90 - 9R - 9T							X	X	X	X						
300X90 - 30S							X	X	X	X						
300X90 - 9I							X	X	X	X						
350X60 - 35G							X	X	X	X						
350X80 - 35S							X	X	X	X	X					
400X80 - 40G									X	X	X	X	X	X		X
300X100 - 310I								X	X	X	X	X				
300X135 - 314I									X	X	X	X	X			
300X160 - 316I									X	X	X	X	X			
406X120 - 406I										X	X	X	X	X	X	X
406x140 - 406P										X	X	X	X	X	X	X
420x180 - 420I												X	X	X	X	X

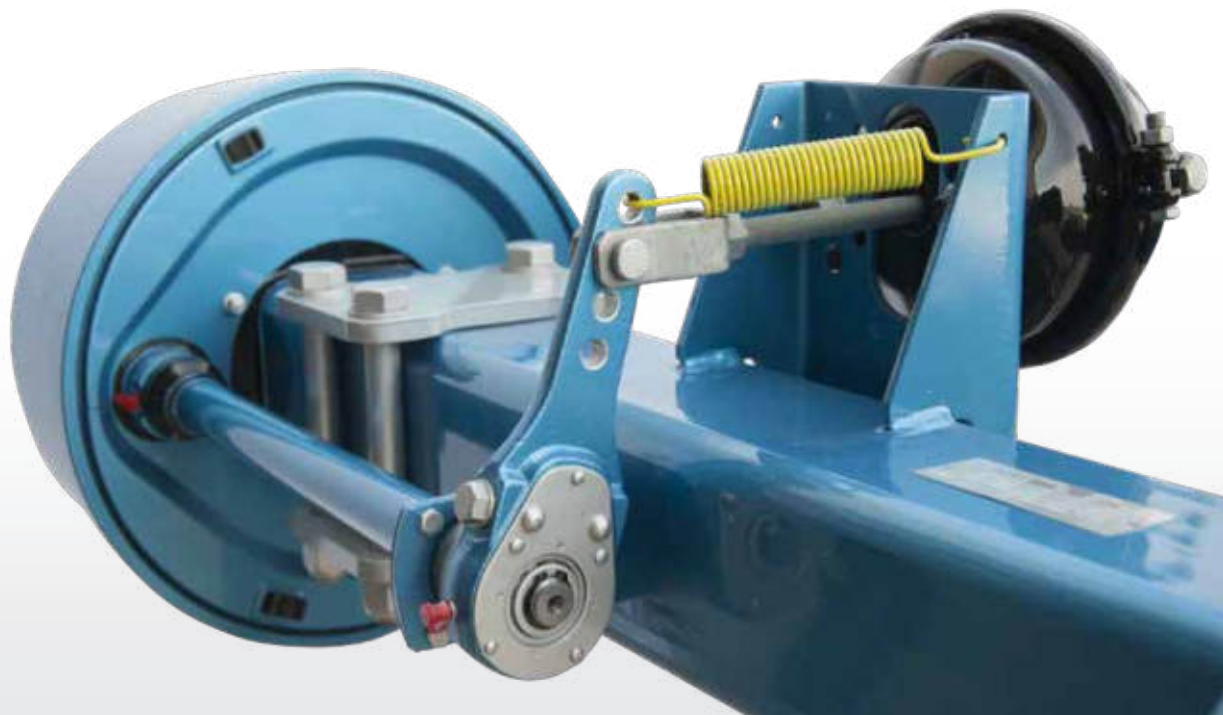

Caratteristiche indicative dei freni _ Indicative characteristics of the brakes

FRENO - Brake		COPPIA CAMMA MAX. Max. cam shaft torque (Nm)	RUOTA MINIMA Min wheel	Ø ESTERNO TAMBURO Drum external Ø (mm)	LEVA - Lever	
TIPO Type	DIMENSIONI Dimensions				mm	TIPO Type
140	140x30	50	8"	155	90	F
20M	200x40	130	10"	212 L.40 - 220	110-140-175-210	F
22M	200x60	150	10"	213	115-150-180-210-240	F
25M	250x60	470	13"	280	115-150-180-210-240 200-225-250-275-300	F
30M	300x60	550	15"	335	115-150-180-210-240 200-225-250-275-300	F
30G	300x60	550	15"	335	115-150-180-210-240 200-225-250-275-300	F
30S	300x90	1140	15"	345	100-125-150-175-200-225 200-225-250-275-300 100-125-150-175-200 200-225-250-275	F R
9I	300x90 ldr.	P.max 180 BAR	15"	345	100-125-150-175-200	F
310I	300x100	910	15"	345	127-152-178-203 127-152-178-203-228-254 120-135-150-165-180-250	R A
314I	300x135	1000	15"	355	127-152-178-203 127-152-178-203-228-254 120-135-150-165-180-250	R A
316I	300x160	1500	15"	360	127-152-178-203 127-152-178-203-228-254 120-135-150-165-180-250	R A
35G	350x60	900	18"	390	100-125-150-175-200-225 200-225-250-275-300 100-125-150-175-200 200-225-250-275	F R
35S	350x80	970	18"	390	100-125-150-175-200-225 200-225-250-275-300 100-125-150-175-200 200-225-250-275	F R
40G	400x80	1140	19,5"	440	100-125-150-175-200 225-250-275-300 100-125-150-175-200 200-225-250-275	F R
406I	406x120	1375	19,5"	460	127-152-178-203 127-152-178-203-228-254 120-135-150-165-180-250	R A
406P	406x140	1350	19,5"	460	127-152-178-203 127-152-178-203-228-254 120-135-150-165-180-250	R A
420I	420x180	1860	20,5"	478	127-152-178-203 127-152-178-203-228-254 120-135-150-165-180-250	R A

F = LEVA FISSA - Fixed lever
R = LEVA REGISTRABILE - Adjustable lever
A = LEVA AUTOMATICA - Automatic lever

Nel caso di calcoli di frenatura fatti secondo normative specifiche, fare riferimento alla coppia massima indicata sul verbale del freno, testato secondo tali normative.

In the case of brake calculations made in accordance with specific regulations, please refer to the maximum torque indicated on the report of the brake, tested in accordance with these regulations.





ATTACCHI fittings





Attacchi _ Fittings

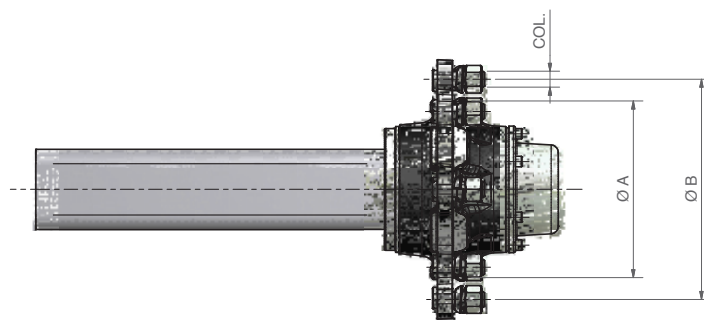

ATTACCHI Fittings				BILLETTA PIENA - Full beam											
N°FORI Holes	COL.	A	B	30	35	40	45	50	55	60	70	80	90	100	110
4	M12	62	95	S	S	S									
4	M12	60	100		S	S									
4	M12	58	98	S	S	S									
4	M16	84	130		S	S	S								
5	M16	94	140			S	S	S							
5	M14	66	112			S	S								
6	M18	160	205					S	S	S/G	S/G	S/G			
8	M18	220	275								S/G	S/G	S/G		
8	M20	220	275									S/G	S/G	S/G	S/G
10	M22	280	335										S/G	S/G	S/G
10	M22	175	225										S/G	S/G	S/G

ATTACCHI Fittings				TUBOLARI - tubulars					
N°FORI Holes	COL.	A	B	110x12,5	120x12,5	130x14	Ø127x20	150x14	150x16
4	M12	62	95						
4	M12	60	100						
4	M12	58	98						
4	M16	84	130						
5	M16	94	140						
5	M14	66	112						
6	M18	160	205	S/G					
8	M18	220	275	S/G	S/G				
8	M20	220	275	S/G	S/G	S/G	S/G		
10	M22	280	335	S/G	S/G	S/G	S/G	S/G	S/G
10	M22	175	225		S/G	S/G			

S = SEMPLICE / Standard
G = GEMELLATO / Twin

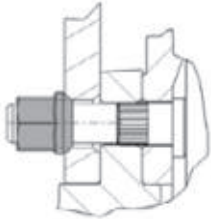

Coppie di serraggio _ Torque

TIPO DI DADO E RONDELLA Type of nut and washer	FILETTATURA Thread	DISCHI BUGNATI Dished discs	DISCHI PIANI IN St.37 Flat discs St.37	DISCHI PIANI IN St.52 Flat discs St.52	FORO RUOTA Wheel Hole Ø	RAGGIO SEDE Seat Radius
DADI CON COLLARE SFERICO DADI CONICI Nut with spherical collar, conical nuts 			COLONNETTA IN CLASSE Studbolt class 8,8	COLONNETTA IN CLASSE Studbolt class 10,9		
		Nm			mm	
	M12 x 1,5	90				
	M14 x 1,5	160	160	220		
	M16 x 1,5	230	230	330	18,5	14
M18 x 1,5	310	330	360	21,5	16	

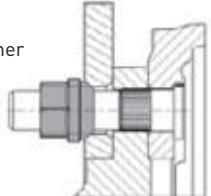
TIPO DI DADO E RONDELLA Type of nut and washer	FILETTATURA Thread	DISCHI BUGNATI Dished discs	DISCHI PIANI IN St.37 Flat discs St.37	DISCHI PIANI IN St.52 Flat discs St.52	FORO RUOTA Wheel Hole Ø	RAGGIO SEDE Seat Radius
DADI CON COLLARE PIANO E RONDELLA SFERICA Nut with flat collar and spherical washer 			COLONNETTA IN CLASSE Studbolt class 8,8	COLONNETTA IN CLASSE Studbolt class 10,9		
		Nm			mm	
	M18 x 1,5	210	270	360	21,5	16
	M20 x 1,5		360	420	27	18
M22 x 1,5		460	550	27	18	

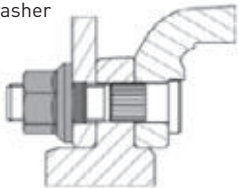
TIPO DI DADO E RONDELLA Type of nut and washer	FILETTATURA Thread	DISCHI BUGNATI Dished discs	DISCHI PIANI IN St.37 Flat discs St.37	DISCHI PIANI IN St.52 Flat discs St.52
DADI CON RONDELLA PIANA GIREVOLE Nut with flat seat captive washer 			COLONNETTA IN CLASSE Studbolt class 8,8	COLONNETTA IN CLASSE Studbolt class 10,9
		Nm		
	M18 x 1,5		260	360
	M20 x 1,5		350	500
M22 x 1,5		450	650	

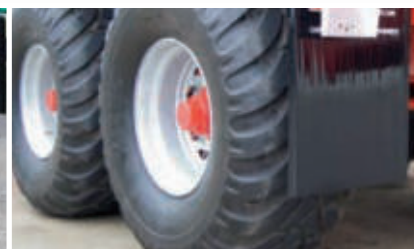





ASSALI axles

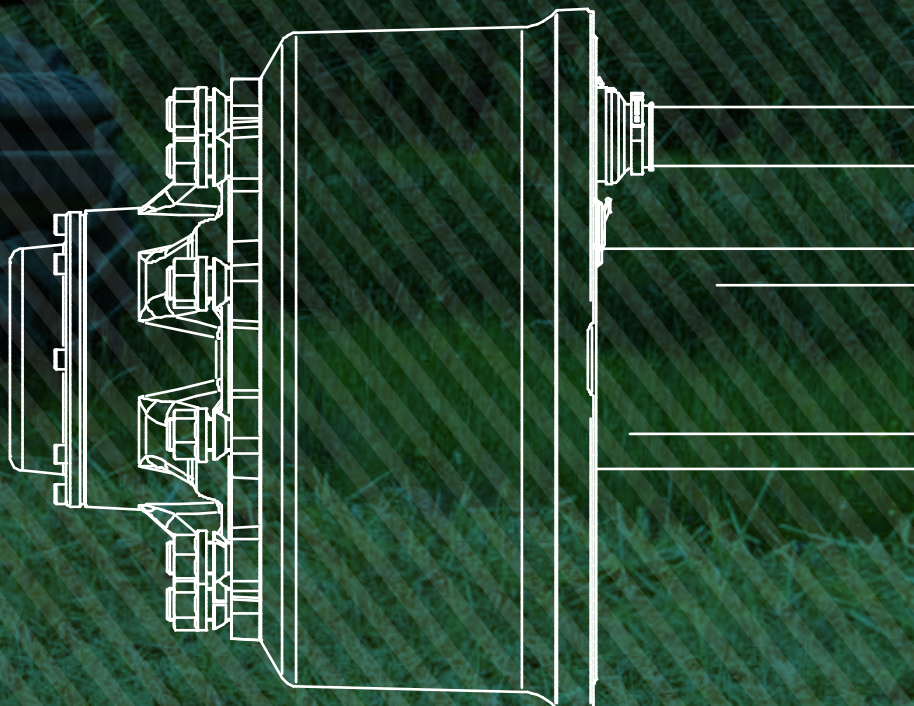



Assali e semiassi _ Axles and stub axles

N.B. Le portate riportate in questo catalogo sono le massime ammissibili per le velocità e per le applicazioni indicate. Ne consegue che è possibile aumentare lo sbalzo indicato a catalogo diminuendo proporzionalmente la portata indicata a catalogo ma non il contrario.

Portata massima	Portata a catalogo * Sbalzo a catalogo / Sbalzo utilizzato dal cliente
Sbalzo massimo	Sbalzo a catalogo * Portata a catalogo / Portata richiesta dal cliente

Portata massima e sbalzo massimo sono riferiti all'applicazione per cui l'assale viene scelto.

Lo sbalzo "H" in tabella è riferito alla portata indicata nella configurazione monoasse a 25 km/h, per calcolare lo sbalzo "H" nelle altre configurazioni procedere come segue:

H indicato in tabella * portata monoasse a 25 km/h / portata indicata nella configurazione per cui si vuole conoscere lo sbalzo.

Esempio:

Per conoscere lo sbalzo del codice A03004412 a 40 km/h in tandem: "H" A3004412 40 km/h tandem = $950 \text{ kg} * 135 \text{ mm} / 800 \text{ kg} = 160 \text{ mm}$.

N.B. The capacities indicated in this catalogue are the maximum allowed for the speed and applications specified. It is possible therefore to increase the overhang indicated in the catalogue by proportionally decreasing the capacity also indicated in the catalogue, but not vice versa.

Maximum capacity	Capacity indicated in the catalogue* Overhang indicated in the catalogue / Overhang used by the customer
Maximum overhang	Overhang indicated in the catalogue* Capacity indicated in the catalogue / Capacity request by the customer

Maximum capacity and maximum overhang are related to the intended axle application.

The overhang "H" in the table is referred to the capacity indicated in the single-axle configuration at 25 km/h, in order to calculate the overhang "H" in the other configurations proceed as follow:

H indicated in the table * capacity single-axle at 25 km/h / capacity indicated in the configuration for which you want to know the overhang.

Example:

To find out the overhang for the code A03004412 at 40 km/h in tandem: "H" A3004412 40 km/h tandem = $950 \text{ kg} * 135 \text{ mm} / 800 \text{ kg} = 160 \text{ mm}$.

Il codice che identifica i prodotti TVZ ha la seguente struttura.

The code that identifies our products is create as follows.

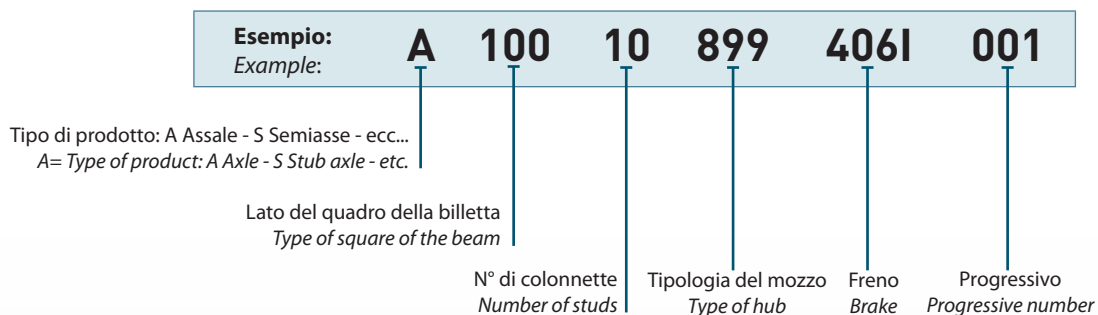

Assali quadri _ Square axles

25-40 km/h



QUADRI - SQUARES

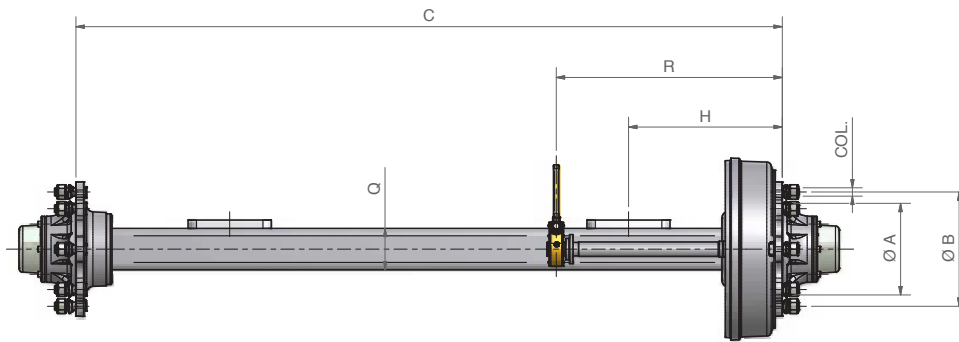
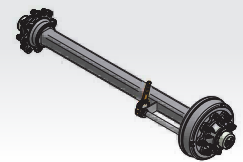

CODICE Code	Q QUADRO Square (mm)	25 km/h			40 km/h			H SBALZO Overhang (mm)
		2 ASSI Axles (kg) 	MONO Mono (kg) 	TANDEM Tandem (kg) 	2 ASSI Axles (kg) 	MONO Mono (kg) 	TANDEM Tandem (kg) 	
A03004412	30	950	950	850	900	900	800	135
A03504412	35	950	950	850	900	900	800	215
A03504420	35	1100	1100	950	900	900	850	185
A04004412	40	950	950	850	900	900	800	325
A04004440	40	1450	1450	1300	1300	1300	1200	210
A04005520	40	1900	1900	1700	1750	1750	1600	160
A04505530	45	2500	2500	2100	2100	2100	1950	175
A05005540	50	3300	3300	2800	2800	2800	2500	180
A05006540	50	3300	3300	2800	2800	2800	2500	180
A05505540	55	3300	3300	2800	2800	2800	2500	240
A05506630	55	4000	4000	3500	3500	3500	3000	200
A06006640	60	4800	4800	4200	4200	4200	3800	215
A07006645	70	6000	6000	5100	5100	5100	4300	275
A07006661	70	7200	7200	6700	6700	6700	6000	225
A07008661	70	7200	7200	6700	6700	6700	6000	225
A08006661	80	7200	7200	6700	6700	6700	6000	340
A08008661	80	7200	7200	6700	6700	6700	6000	340
A08006668	80	8200	8200	7400	7700	7700	7000	300
A08008668	80	8200	8200	7400	7700	7700	7000	300
A08006671	80	10000	10000	9000	9200	9200	8500	245
A08008671	80	10000	10000	9000	9200	9200	8500	245
A09006671	90	10000	10000	9000	9200	9200	8500	350
A09008671	90	10000	10000	9000	9200	9200	8500	350
A09008880	90	11800	11800	10000	10000	10000	9500	295
A09010880	90	11800	11800	10000	10000	10000	9500	295
A10008880	100	11800	11800	10000	10000	10000	9500	400
A10010880	100	11800	11800	10000	10000	10000	9500	400
A10008899	100	14000	14000	12500	13000	13000	11500	340
A10010899	100	14000	14000	12500	13000	13000	11500	340
A11010991	110	15000	15000	14000	14000	14000	13000	410
A11010994	110	16000	16000	14500	15000	15000	14000	380
A12008880	120x12	11800	11800	10000	10000	10000	9500	430
A12010880	120x12	11800	11800	10000	10000	10000	9500	430
A12008899	120x12	14000	14000	12500	13000	13000	11500	360
A12010899	120x12	14000	14000	12500	13000	13000	11500	360
A13008899	130x14	14000	14000	12500	13000	13000	11500	480
A13010899	130x14	14000	14000	12500	13000	13000	11500	480
A13010991	130x14	15000	15000	14000	14000	14000	13000	445
A13010994	130x14	16000	16000	14500	15000	15000	14000	415
A15010994	150x14	16000	16000	14500	15000	15000	14000	585
A15010998	150x16	18500	18500	17000	17500	17500	16000	550

R = Contattare il nostro ufficio commerciale per la misura del perno oliva.

R = Please take contact with our sales department for the measure of the camshaft.



Assali quadri _ Square axles

60-80 km/h



QUADRI - SQUARES

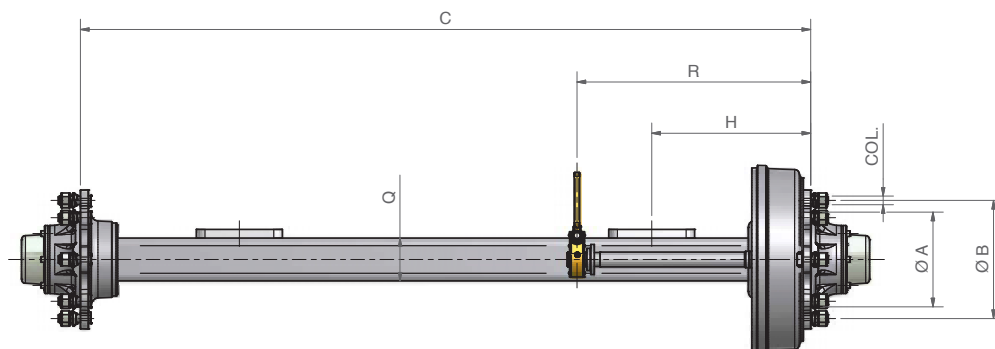
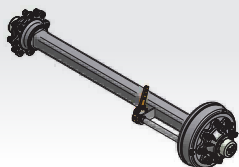





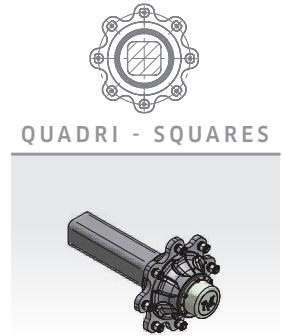
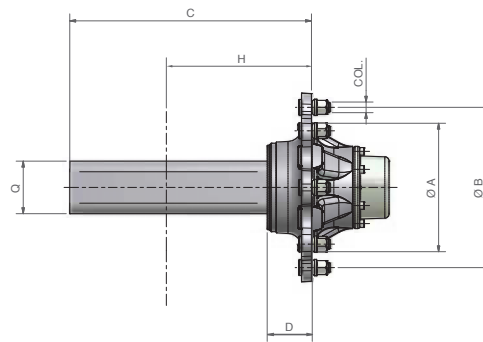
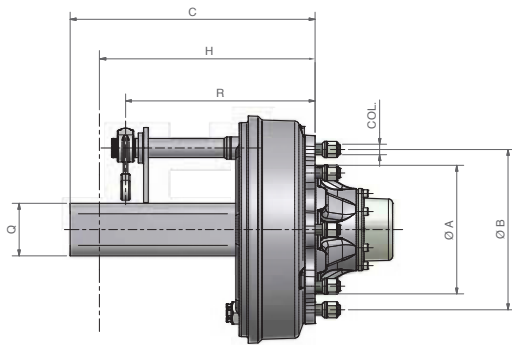

CODICE Code	Q QUADRO Square (mm)	60 km/h			80 km/h			H SBALZO Overhang (mm)
		2 ASSI Axles (kg) 	MONO mono (kg) 	TANDEM Tandem (kg) 	2 ASSI Axles (kg) 	MONO mono (kg) 	TANDEM Tandem (kg) 	
A04005520	40	1600	1600	1450				140
A04505530	45	1950	1950	1750				155
A05005540	50	2500	2500	2250				165
A05006540	50	2500	2500	2250				165
A05505540	55	2500	2500	2250				220
A05506630	55	3000	3000	2750				185
A06006640	60	3800	3800	3500				190
A07006645	70	4300	4300	3850				255
A07006660	70	6000	6000	5400	5400	5400	4800	185
A07008660	70	6000	6000	5400	5400	5400	4800	185
A08006660	80	6000	6000	5400	5400	5400	4800	335
A08008660	80	6000	6000	5400	5400	5400	4800	335
A08006668	80	7000	7000	6300	6300	6300	5700	290
A08008668	80	7000	7000	6300	6300	6300	5700	290
A08006671	80	8500	8500	7700	7700	7700	7000	240
A08008671	80	8500	8500	7700	7700	7700	7000	240
A09006671	90	8500	8500	7700	7700	7700	7000	330
A09008671	90	8500	8500	7700	7700	7700	7000	330
A09008880	90	9500	9500	8500	8500	8500	7500	295
A09010880	90	9500	9500	8500	8500	8500	7500	295
A10008880	100	9500	9500	8500	8500	8500	7500	400
A10010880	100	9500	9500	8500	8500	8500	7500	400
A10008899	100	12000	12000	11000	11000	11000	10000	320
A10010899	100	12000	12000	11000	11000	11000	10000	320
A11010991	110	13000	13000	12000	12000	12000	11000	370
A11010994	110	14000	14000	13000	13000	13000	12000	340
A12008880	120x12	9500	9500	8500	8500	8500	7500	475
A12010880	120x12	9500	9500	8500	8500	8500	7500	475
A12008899	120x12	12000	12000	11000	11000	11000	10000	375
A12010899	120x12	12000	12000	11000	11000	11000	10000	375
A13008899	130x14	12000	12000	11000	11000	11000	10000	480
A13010899	130x14	12000	12000	11000	11000	11000	10000	480
A13010991	130x14	13000	13000	12000	12000	12000	11000	445
A13010994	130x14	14000	14000	13000	13000	13000	12000	415
A15010994	150x14	14000	14000	13000	13000	13000	12000	585
A15010998	150x16	16000	16000	15000	14500	14500	14000	560

R = Contattare il nostro ufficio commerciale per la misura del perno oliva. R = Please take contact with our sales department for the measure of the camshaft.

Semiassi quadri _ Square stub axles

25-40 km/h



CODICE Code	Q QUADRO Square (mm)	D (mm)	25 km/h			40 km/h			H SBALZO Overhang (mm)
			2 ASSI Axles (kg) 	MONO Mono (kg) 	TANDEM Tandem (kg) 	2 ASSI Axles (kg) 	MONO Mono (kg) 	TANDEM Tandem (kg) 	
S03004412	30	30	475	475	425	450	450	400	135
S03504412	35	30	475	475	425	450	450	400	215
S03504420	35	30	550	550	475	450	450	425	185
S04004412	40	30	475	475	425	450	450	400	325
S04004440	40	35	725	725	650	650	650	600	210
S04005520	40	40	950	950	850	875	875	800	160
S04505530	45	45	1250	1250	1050	1050	1050	975	175
S05005540	50	45	1650	1650	1400	1400	1400	1250	180
S05006540	50	45	1650	1650	1400	1400	1400	1250	180
S05505540	55	45	1650	1650	1400	1400	1400	1250	240
S05506630	55	50	2000	2000	1750	1750	1750	1500	200
S06006640	60	50	2400	2400	2100	2100	2100	1900	215
S07006645	70	50	3000	3000	2550	2550	2550	2150	275
S07006661	70	65	3600	3600	3350	3350	3350	3000	225
S07008661	70	65	3600	3600	3350	3350	3350	3000	225
S08006661	80	65	3600	3600	3350	3350	3350	3000	340
S08008661	80	65	3600	3600	3350	3350	3350	3000	340
S08006668	80	68	4100	4100	3700	3850	3850	3500	300
S08008668	80	68	4100	4100	3700	3850	3850	3500	300
S08006671	80	75	5000	5000	4500	4600	4600	4250	245
S08008671	80	75	5000	5000	4500	4600	4600	4250	245
S09006671	90	75	5000	5000	4500	4600	4600	4250	350
S09008671	90	75	5000	5000	4500	4600	4600	4250	350
S09008880	90	85	5900	5900	5000	5000	5000	4750	295
S09010880	90	85	5900	5900	5000	5000	5000	4750	295
S10008880	100	85	5900	5900	5000	5000	5000	4750	400
S10010880	100	85	5900	5900	5000	5000	5000	4750	400
S10008899	100	87	7000	7000	6250	6500	6500	5750	340
S10010899	100	87	7000	7000	6250	6500	6500	5750	340
S11010991	110	90	7500	7500	7000	7000	7000	6500	410
S11010994	110	90	8000	8000	7250	7500	7500	7000	380
S12008880	120x12	85	5900	5900	5000	5000	5000	4750	430
S12010880	120x12	85	5900	5900	5000	5000	5000	4750	430
S12008899	120x12	85	7000	7000	6250	6500	6500	5750	360
S12010899	120x12	85	7000	7000	6250	6500	6500	5750	360
S13008899	130x14	85	7000	7000	6250	6500	6500	5750	480
S13010899	130x14	85	7000	7000	6250	6500	6500	5750	480
S13010991	130x14	90	7500	7500	7000	7000	7000	6500	445
S13010994	130x14	90	8000	8000	7250	7500	7500	7000	415
S15010994	150x14	90	8000	8000	7250	7500	7500	7000	585
S15010998	150x16	115	9250	9250	8500	8750	8750	8000	550

Semiassi quadri _ Square stub axles

60-80 km/h



QUADRI - SQUARES

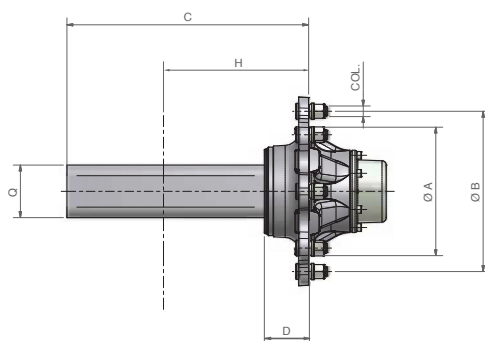
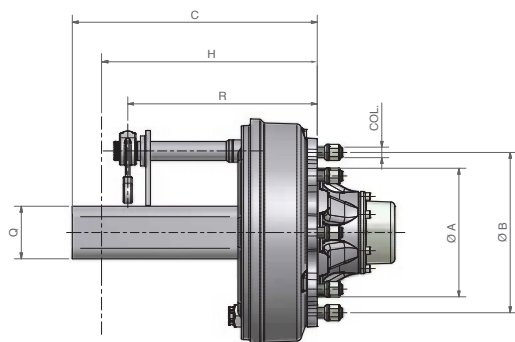
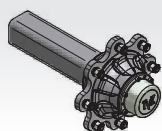





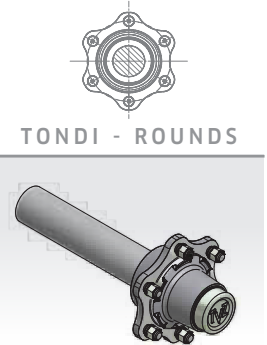
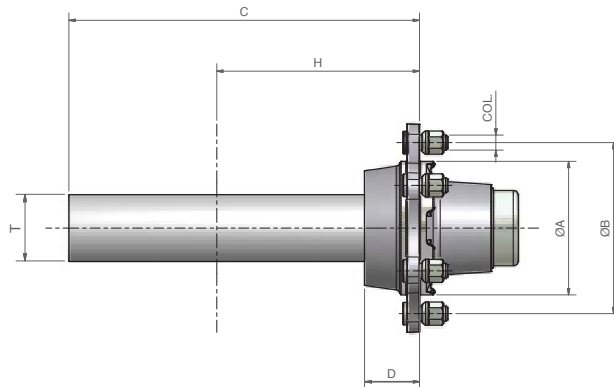

CODICE Code	Q QUADRO Square (mm)	D (mm)	60 km/h			80 km/h			H SBALZO Overhang (mm)
			2 ASSI Axles (kg) 	MONO Mono (kg) 	TANDEM Tandem (kg) 	2 ASSI Axles (kg) 	MONO Mono (kg) 	TANDEM Tandem (kg) 	
S04005520	40	40	800	800	725				140
S04505530	45	45	975	975	875				155
S05005540	50	45	1250	1250	1125				165
S05006540	50	45	1250	1250	1125				165
S05505540	55	45	1250	1250	1125				220
S05506630	55	50	1500	1500	1375				185
S06006640	60	50	1900	1900	1750				190
S07006645	70	50	2150	2150	1925				255
S07006661	70	65	3000	3000	2700	2700	2700	2400	185
S07008661	70	65	3000	3000	2700	2700	2700	2400	185
S08006661	80	65	3000	3000	2700	2700	2700	2400	335
S08008661	80	65	3000	3000	2700	2700	2700	2400	335
S08006668	80	68	3500	3500	3150	3150	3150	2850	290
S08008668	80	68	3500	3500	3150	3150	3150	2850	290
S08006671	80	75	4250	4250	3850	3850	3850	3500	240
S08008671	80	75	4250	4250	3850	3850	3850	3500	240
S09006671	90	75	4250	4250	3850	3850	3850	3500	330
S09008671	90	75	4250	4250	3850	3850	3850	3500	330
S09008880	90	85	4750	4750	4250	4250	4250	3750	295
S09010880	90	85	4750	4750	4250	4250	4250	3750	295
S10008880	100	85	4750	4750	4250	4250	4250	3750	400
S10010880	100	85	4750	4750	4250	4250	4250	3750	400
S10008899	100	87	6000	6000	5500	5500	5500	5000	320
S10010899	100	87	6000	6000	5500	5500	5500	5000	320
S11010991	110	90	6500	6500	6000	6000	6000	5500	370
S11010994	110	90	7000	7000	6500	6500	6500	6000	340
S12008880	120x12	85	4750	4750	4250	4250	4250	3750	475
S12010880	120x12	85	4750	4750	4250	4250	4250	3750	475
S12008899	120x12	85	6000	6000	5500	5500	5500	5000	375
S12010899	120x12	85	6000	6000	5500	5500	5500	5000	375
S13008899	130x14	85	6000	6000	5500	5500	5500	5000	480
S13010899	130x14	85	6000	6000	5500	5500	5500	5000	480
S13010991	130x14	90	6500	6500	6000	6000	6000	5500	445
S13010994	130x14	90	7000	7000	6500	6500	6500	6000	415
S15010994	150x14	90	7000	7000	6500	6500	6500	6000	585
S15010998	150x16	115	8000	8000	7500	7250	7250	7000	560

R = Contattare il nostro ufficio commerciale per la misura del perno oliva. R = Please take contact with our sales department for the measure of the camshaft.

Semiassi tondi _ Round stub axle

25-40 km/h



CODICE Code	T TONDO Round (mm)	D (mm)	25 km/h			40 km/h			H SBALZO Overhang (mm)
			2 ASSI Axles (kg) 	MONO Mono (kg) 	TANDEM Tandem (kg) 	2 ASSI Axles (kg) 	MONO Mono (kg) 	TANDEM Tandem (kg) 	
S02904412	30	30	475	475	425	450	450	400	85
S03404412	35	30	475	475	425	450	450	400	140
S03404420	35	30	550	550	475	450	450	425	120
S03904420	40	30	550	550	475	450	450	425	180
S03904440	40	35	725	725	650	650	650	600	135
S04405520	45	40	950	950	850	875	875	800	145
S04905530	50	45	1250	1250	1050	1050	1050	975	155
S05405540	55	45	1650	1650	1400	1400	1400	1250	155
S05406540	55	45	1650	1650	1400	1400	1400	1250	155
S05905540	60	45	1650	1650	1400	1400	1400	1250	200
S05906630	60	50	2000	2000	1750	1750	1750	1500	165
S06906640	70	50	2400	2400	2100	2100	2100	1900	220
S07906661	80	65	3600	3600	3350	3350	3350	3000	220
S07908661	80	65	3600	3600	3350	3350	3350	3000	220
S07906668	80	68	4100	4100	3700	3850	3850	3500	190
S07908668	80	68	4100	4100	3700	3850	3850	3500	190
S08906671	90	75	5000	5000	4500	4600	4600	4250	225
S08908671	90	75	5000	5000	4500	4600	4600	4250	225
S08908880	90	85	5900	5900	5000	5000	5000	4750	190
S08910880	90	85	5900	5900	5000	5000	5000	4750	190
S09908880	100	85	5900	5900	5000	5000	5000	4750	260
S09910880	100	85	5900	5900	5000	5000	5000	4750	260
S09908899	100	87	7000	7000	6250	6500	6500	5750	215
S09910899	100	87	7000	7000	6250	6500	6500	5750	215





Semiassi sterzanti tipo L _ Steering stub axles "L type"

25 km/h



QUADRI - SQUARES

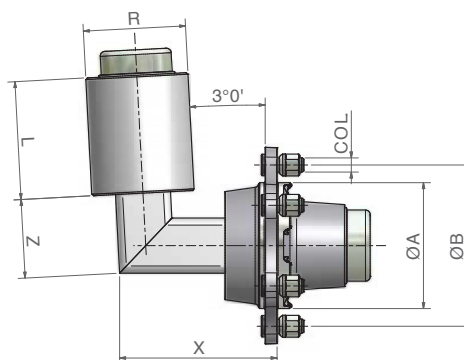
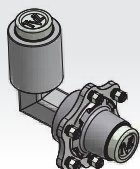

CODICE Code	QUADRO Square (mm)	R (mm)	L (mm)	Z (mm)	X (mm)	PORTATA Capacity (kg)	N.C.	A (mm)	B (mm)
L04004431000	40	65	65	80	140	650	4 M12	58	98
L04004431000	40	65	65	80	140	650	4 M12	62	95
L05005540000	50	95	100	90	160	1400	5 M16	94	140
L05006540000	50	95	100	90	180	1400	6 M18	160	205
L06006640000	60	120	120	90	180	2000	6 M18	160	205
L07006661000	70	130	150	100	200	3000	6 M18	160	205
L08008661000	80	130	150	100	200	3000	8 M18	220	275

Semiassi sterzanti tipo Y _ Steering stub axles "Y type"

25 km/h



QUADRI - SQUARES

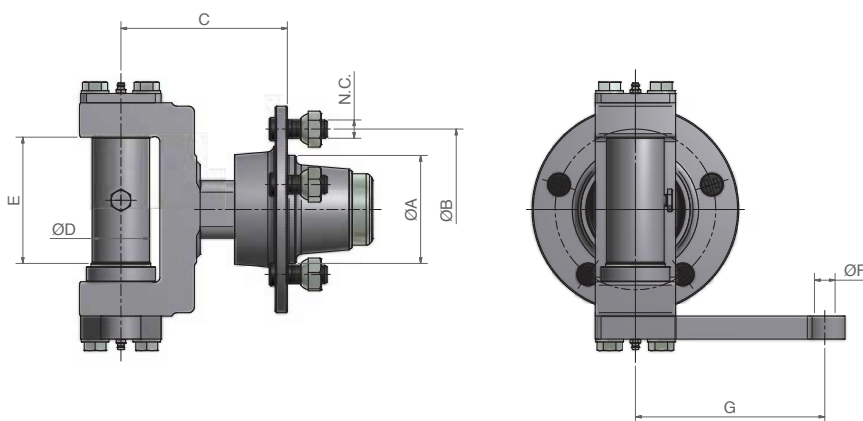
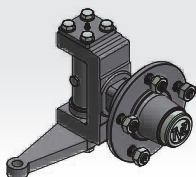

CODICE Code	C (mm)	D (mm)	E (mm)	F (mm)	G (mm)	PORTATA Capacity (kg)	N.C.	A (mm)	B (mm)
I04505520000	145	50	105	18	165	950	5 M16	94	140
I04505530000	145	50	105	18	165	1250	5 M16	94	140
I05005540000	145	50	105	18	165	1500	5 M16	94	140
I05006540000	145	50	105	18	165	1500	6 M18	160	205

Semiassi ribassati _ Offset stub axles

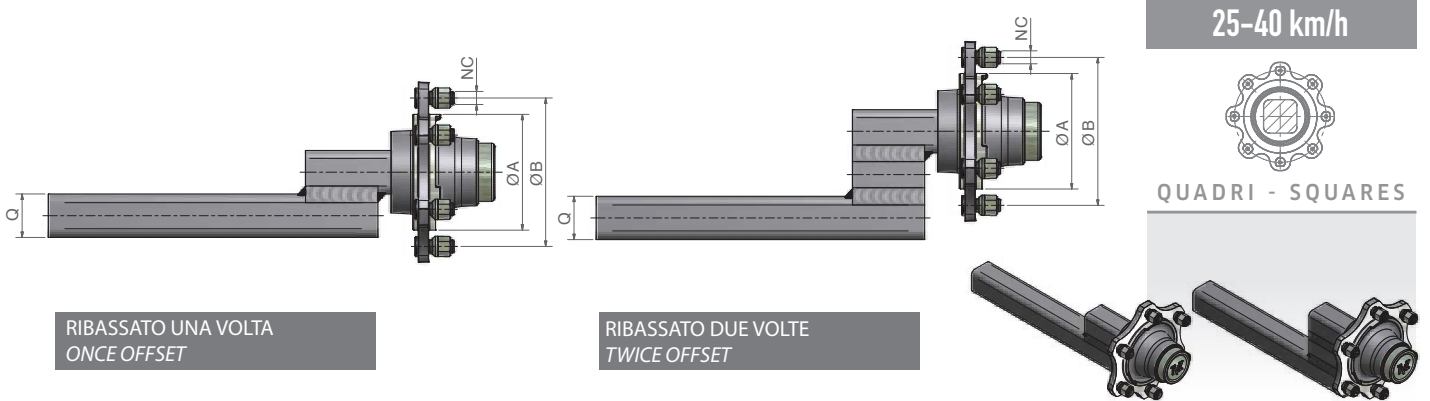

RIBASSATO UNA VOLTA
ONCE OFFSET

RIBASSATO DUE VOLTE
TWICE OFFSET

CODICE Code	QUADRO Square (mm)	N.C.	A (mm)	B (mm)	MONOASSE Single axle (kg)	
					25 km/h	40 km/h
M04004412000	40	4 M12	58	98	475	450
M04004412000	40	4 M12	62	95	475	450
M04004440000	50	4 M12	58	98	725	650
M04004440000	50	4 M12	62	95	725	650
M04005520000	60	5 M16	94	140	950	875
M04505530000	70	5 M16	94	140	1250	1050
M05005540000	80	5 M16	94	140	1650	1400
M05006540000	80	6 M18	160	205	1650	1400
M05506630000	80	6 M18	160	205	2000	1750
M06006640000	80	6 M18	160	205	2400	2100
M07006661000	80	6 M18	160	205	3600	3350
M07008661000	80	8 M18	220	275	3600	3350

Semiassi per dischi frangi zolle _ Stub axles for disk roller scrapers

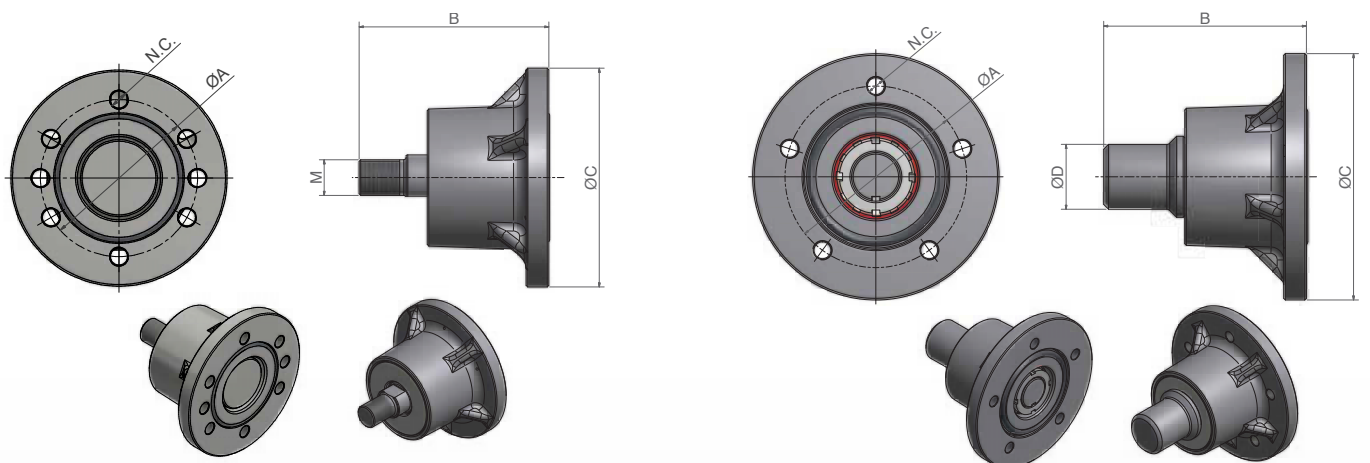

VERSIONE AVVITATA - SCREWED VERSION

ØA (mm)	N.C.	B (mm)	ØC (mm)	M
98	4 / 6 - M12x1,25	117	135	M22x1,5
112	5 - M12x1,5	117	152	M22x1,5

VERSIONE SALDATA - WELDED VERSION

ØA (mm)	N.C.	B (mm)	ØC (mm)	ØD (mm)
98	4 / 6 - M12x1,25	125	135	40
112	5 - M12x1,5	125	152	40

Assali sterzanti SQR

QUANDO DEVE ESSERE USATO

L'usura dei pneumatici rappresenta in percentuale la quota più alta dei costi di esercizio di un rimorchio agricolo. La responsabilità di tale consumo è da attribuire all'ultimo assale di una sospensione che se fisso, ad ogni curva, dovendo seguire la traiettoria del rimorchio costringe i pneumatici a radere l'asfalto. Oltre a ciò lo chassis e la sospensione in curva si irrigidiscono eccessivamente e ciò comporta per tutto il veicolo una maggiore usura. Questi problemi sono evitati grazie all'utilizzo di uno o due (sospensione tridem) assali autosterzanti, in questo caso le ruote e quindi i pneumatici ruotano perfettamente, la sospensione sterza in curva e segue la traiettoria del trattore.

GIUNTO STERZANTE DI ALTA QUALITÀ

Lo sterzante SQR monta solo bronzine alveolate per garantire un ingrassaggio ideale al perno della cerniera e alla cerniera stessa. Il giunto sterzante risulta essere meno sensibile agli shock termici eventualmente prodotti dalle saldature che il costruttore del veicolo potrebbe apportarvi.

Le bronzine alveolate differenziano molto SQR da altri sterzanti che montano boccole in nylon. Il nylon è un materiale igroscopico, quindi con tolleranze mutevoli in base alle condizioni climatiche ed in particolare in base all'umidità. Il nylon risulta essere molto più soggetto all'usura rispetto ad una bronzina alveolata.

REGOLAZIONE DELLA STERZATURA

SQR è predisposto per una regolazione veloce e precisa dell'angolo di sterzata. Caratteristica estremamente importante per adattare l'assale ad ogni tipologia di veicolo e di utilizzo.

La regolazione è presto fatta agendo su di una vite inserita nel supporto della cerniera e fissata con un dado di sicurezza, regolando la vite si può aumentare o diminuire l'angolo di sterzata.

REGOLAZIONE VELOCE DELLA CONVERGENZA

La convergenza dell'assale SQR è presto regolata semplicemente agendo su i due perni eccentrici che fissano la barra di sterzata alle cerniere.

LEGGEREZZA

Lo studio delle geometrie del giunto sterzante unito all'utilizzo di materiali e componenti di qualità ha permesso di realizzare un prodotto competitivo per quanto riguarda il rapporto tra la sua capacità di carico e il suo peso.

PERNO DELLA CERNIERA CONICO

Il perno conico dello sterzante SQR permette una regolazione precisa dei giochi del giunto sterzante e ne rende veloce la revisione facilitandone la rimozione e il successivo ripristino.

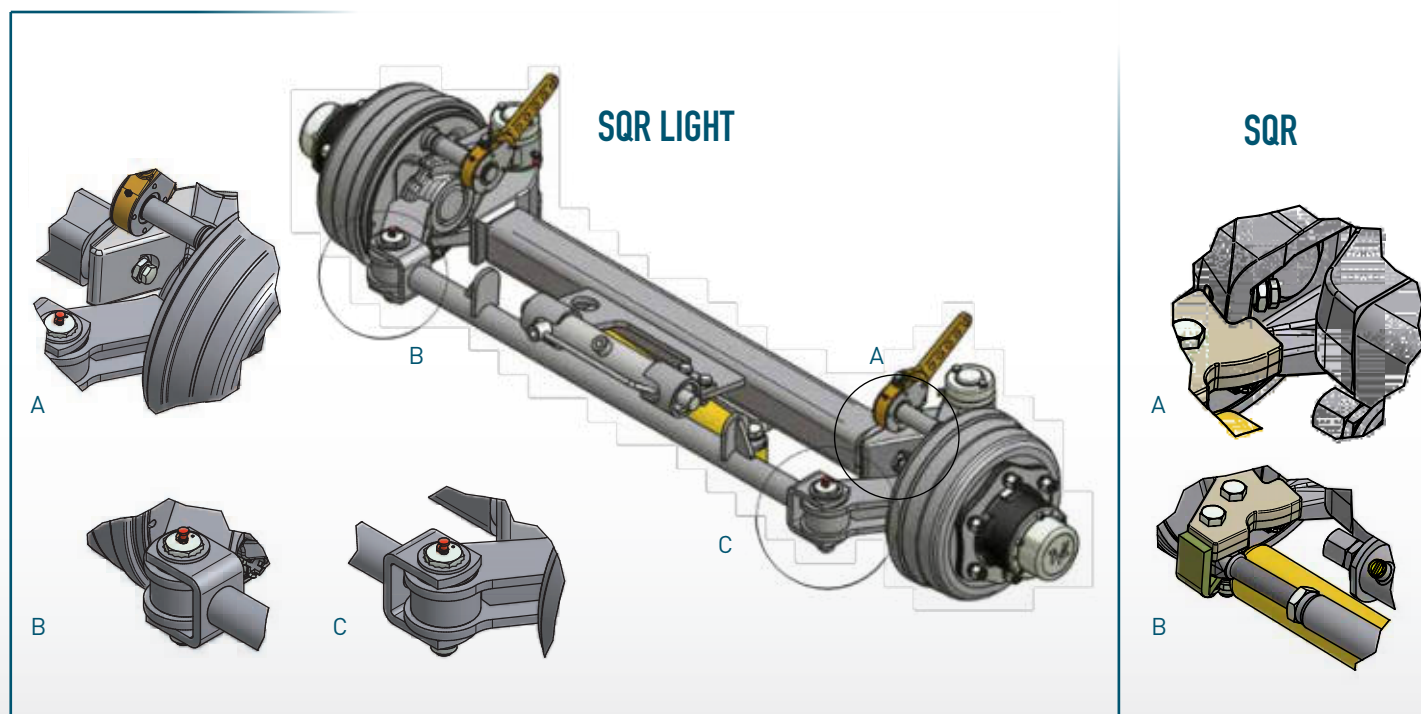

WHEN IT SHOULD BE USED

The tyre wear represents, perceptually, the highest using cost for an agricultural machine. The responsibility of this cost is to put to the last suspension axle, which it is fixed. The tyres are obliged to scrape on the earth at every bend, following the trailer direction. Although, the chassis and the suspension, during the bend, are extremely rigid and so the complete trailer is overstressed to more wear. There problems are avoided substituting the fixed axle with one or two (tridem suspension) steering axles. So the wheels and the tyres turn perfectly, the suspension turns also in bend, following the tractor direction.

HIGH QUALITY STEERING JOINT

The SQR steering is fitted with only bronze bushes with lubrication pockets to guarantee the best lubrication on the hinge pin and the hinge itself. The steering joint is less sensitive to any thermal shock that could be originated by any welding carried out by the vehicle manufacturer. The bronze bushes greatly differentiates SQR from other steering axles that use nylon bushing. Nylon is a hygroscopic material and therefore it presents variable tolerances depending on climatic conditions, in particular humidity. Nylon is more subject to wear and tear than bronze bush.

ADJUSTMENT OF THE STEERING

SQR is prearranged in order to allow for a fast and precise adjustment of the angle of steering.

This characteristic is extremely important to make the axle suitable to every type of vehicle and usage. The adjustment can be made quickly by means of a screw inserted in the hinge support and fixed by means of a safety nut. The angle of steering can be increased or reduced by adjusting this screw.

FAST ADJUSTMENT OF THE WHEEL ALIGNMENT

The alignment of the SQR axle is quickly adjusted by simply operating on two eccentric pins that fix the steering rod to the hinges.

LIGHTNESS

Research on the steering joint geometry together with use of high quality materials and components has resulted in a product that is competitive both on its load-bearing capacity and its weight.

CONICAL HINGE PIN

The conical pin of the SQR steering axle allows for a precise adjustment of slacks in the steering joint and makes overhauling faster, rendering removal and replacing easier.

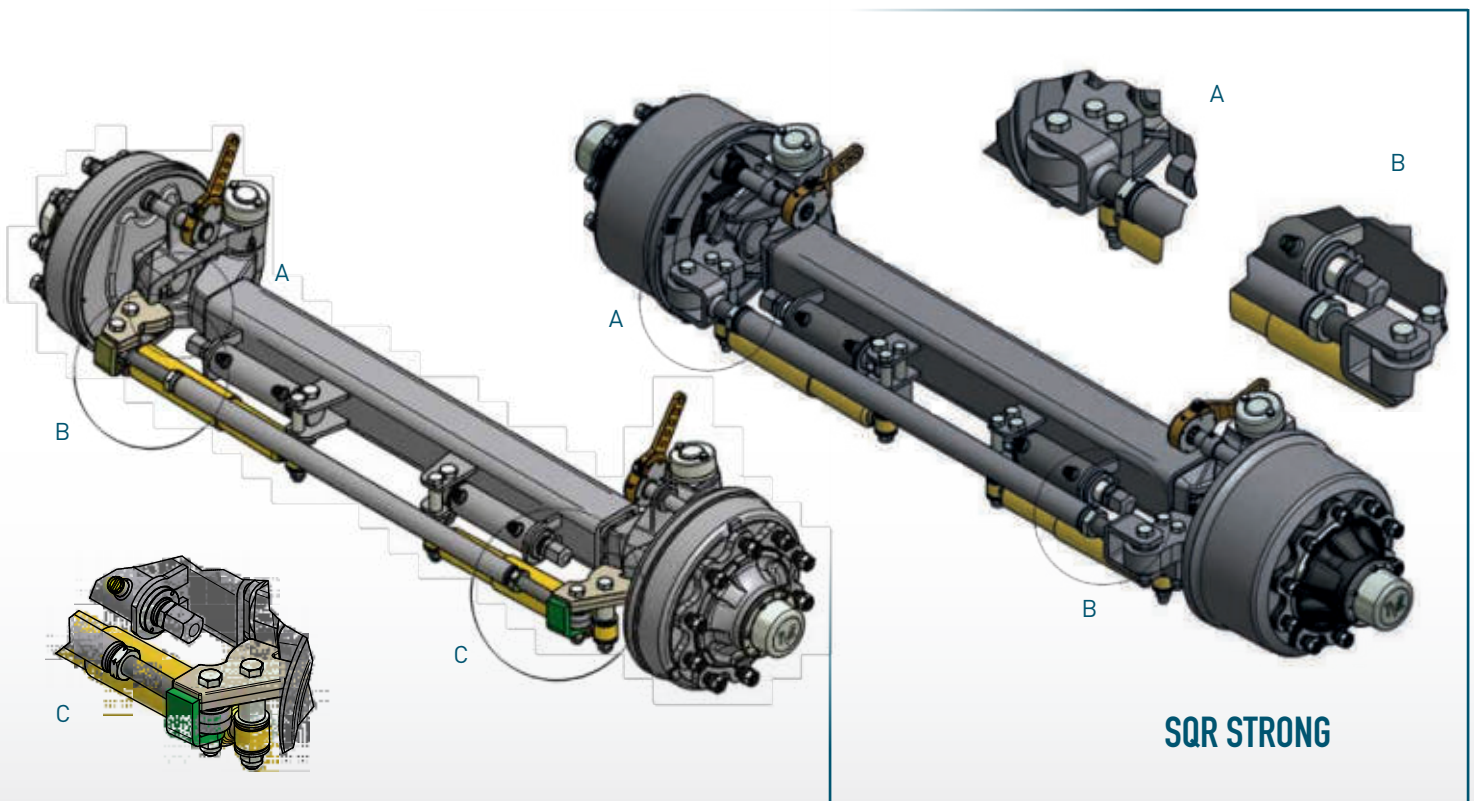



Assali sterzanti SQR light _ Steering axles SQR light

25-40 km/h



QUADRI - SQUARES

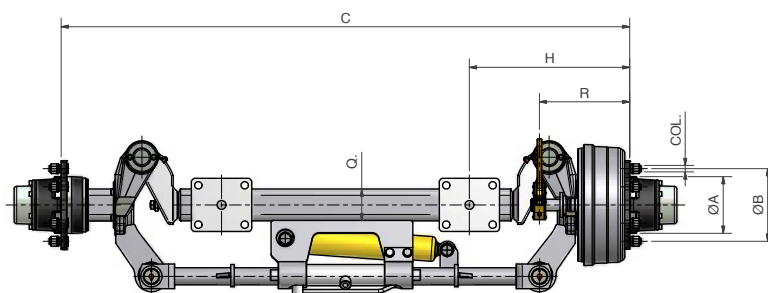
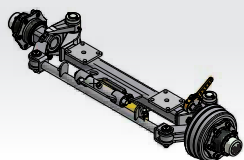

CODICE Code	Q QUADRO Square (mm)	PORTATA - Capacity (kg)		H SBALZO Overhang (mm)	ATTACCO - Fitting		
		25 km/h	40 km/h		NC	A	B
H08006661	80	6700	6000	365	6 M18	160	205
H08008661	80	6700	6000	365	8 M18	220	275
H08006671	80	9000	8500	270	6 M18	160	205
H08008671	80	9000	8500	270	8 M18	220	275
H09006671	90	9000	8500	390	6 M18	160	205
H09008671	90	9000	8500	390	8 M18	220	275
H09008880	90	10000	9500	350	8 M20	220	275
H10008880	100	10000	9500	475	8 M20	220	275
H10008899	100	10500	10000	450	8 M20	220	275
H10010899	100	10500	10000	450	10 M22	280	335
H11010899	110	10500	10000	550	10 M22	280	335
H12010899	120x12	10500	10000	470	10 M22	280	335

60 km/h

CODICE Code	Q QUADRO Square (mm)	PORTATA Capacity (kg) 60 km/h	H SBALZO Overhang (mm)	ATTACCO - Fitting		
				NC	A	B
H08006660	80	5400	375	6 M18	160	205
H08008660	80	5400	375	8 M18	220	275
H08006671	80	7700	260	6 M18	160	205
H08008671	80	7700	260	8 M18	220	275
H09006671	90	7700	365	6 M18	160	205
H09008671	90	7700	365	8 M18	220	275
H09008880	90	8500	330	8 M20	220	275
H10008880	100	8500	450	8 M20	220	275
H10008899	100	9000	430	8 M20	220	275
H10010899	100	9000	430	10 M22	280	335
H11010899	110	9000	530	10 M22	280	335
H12010899	120x12	9000	430	10 M22	280	335

Assali sterzanti SQR _ Steering axles SQR

25-40 km/h

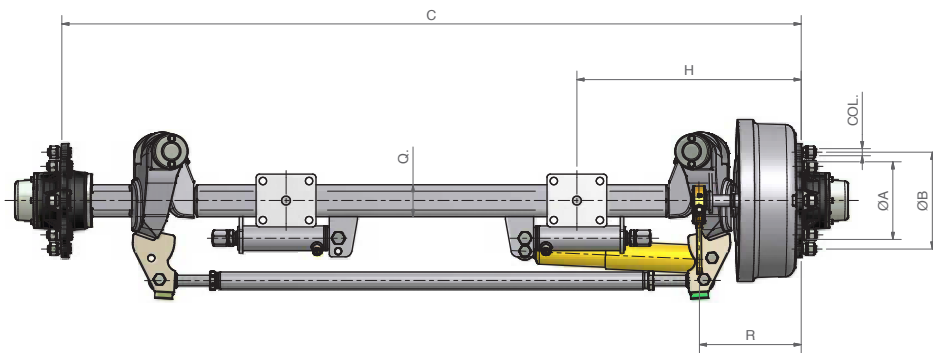

QUADRI - SQUARES

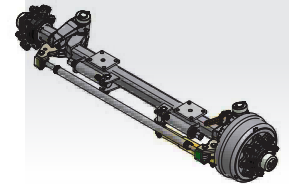

CODICE Code	Q QUADRO Square (mm)	PORTATA - Capacity (kg)		H SBALZO Overhang (mm)	ATTACCO - Fitting		
		25 km/h	40 km/h		NC	A	B
X09006671	90	9000	8500	390	6 M18	160	205
X09008671	90	9000	8500	390	8 M18	220	275
X09008880	90	10000	9500	350	8 M20	220	275
X09010880	90	10000	9500	350	10 M22	280	335
X10008880	100	10000	9500	475	8 M20	220	275
X10010880	100	10000	9500	475	10 M22	280	335
X10008899	100	12500	11500	380	8 M20	220	275
X10010899	100	12500	11500	380	10 M22	280	335
X11010991	110	13000	12000	470	10 M22	280	335
X12010899	120x12	12500	11500	390	10 M22	280	335
X13010991	130x14	13000	12000	510	10 M22	280	335
X13010994	130x14	13000	12000	510	10 M22	280	335

60 km/h

CODICE Code	Q QUADRO Square (mm)	PORTATA Capacity (kg) 60 km/h	H SBALZO Overhang (mm)	ATTACCO - Fitting		
				NC	A	B
X09006671	90	7700	365	6 M18	160	205
X09008671	90	7700	365	8 M18	220	275
X09008880	90	8500	330	8 M20	220	275
X09010880	90	8500	330	10 M22	280	335
X10008880	100	8500	450	8 M20	220	275
X10010880	100	8500	450	10 M22	280	335
X10008899	100	11000	345	8 M20	220	275
X10010899	100	11000	345	10 M22	280	335
X11010991	110	12000	395	10 M22	280	335
X12010899	120x12	11000	350	10 M22	280	335
X13010991	130x14	12000	490	10 M22	280	335
X13010994	130x14	12000	490	10 M22	280	335



Assali sterzanti SQR Strong _ Steering axles SQR Strong

25-40 km/h



QUADRI - SQUARES

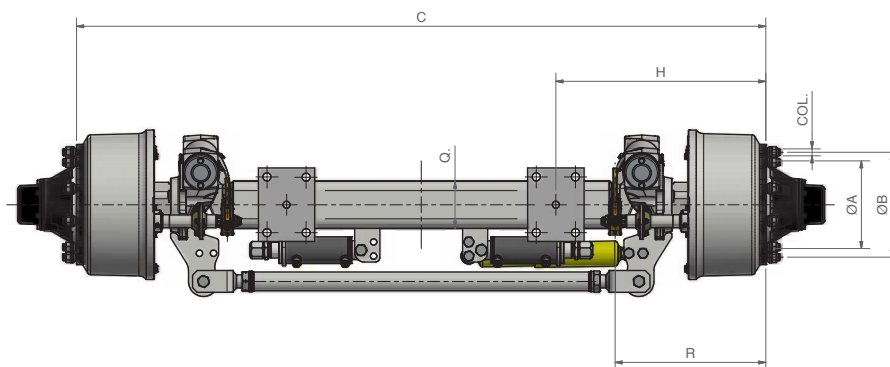
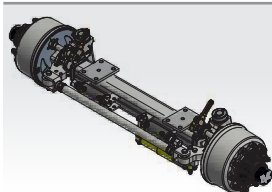

CODICE Code	Q QUADRO Square (mm)	PORTATA - Capacity (kg)		H SBALZO Overhang (mm)	ATTACCO - Fitting		
		25 km/h	40 km/h		NC	A	B
V15010994	150x14	14500	14000	610	10 M22	280	335
V15010998	150x16	16000	16000	600	10 M22	280	335

Per la realizzazione di semiassi sterzanti prego contattare il nostro servizio commerciale, per i semiassi le portate vanno dimezzate; gli assali con tubolare sono disponibili in base alla quantità.

For the steering hubs, please contact our sales office please note that for the stub axles the loading capacity is the half of an axle please ask for the availability of the axles with tubular instead of full beam.

60 km/h

CODICE Code	Q QUADRO Square (mm)	PORTATA Capacity (kg) 60 km/h	H SBALZO Overhang (mm)	ATTACCO - Fitting		
				NC	A	B
V15010994	150x14	13000	600	10 M22	280	335
V15010998	150x16	15000	580	10 M22	280	335

Per la realizzazione di semiassi sterzanti prego contattare il nostro servizio commerciale, per i semiassi le portate vanno dimezzate; gli assali con tubolare sono disponibili in base alla quantità.

For the steering hubs, please contact our sales office please note that for the stub axles the loading capacity is the half of an axle please ask for the availability of the axles with tubular instead of full beam.

Assali sterzanti comandati SQL _ SQL forced steering axles

25-40 km/h



QUADRI - SQUARES

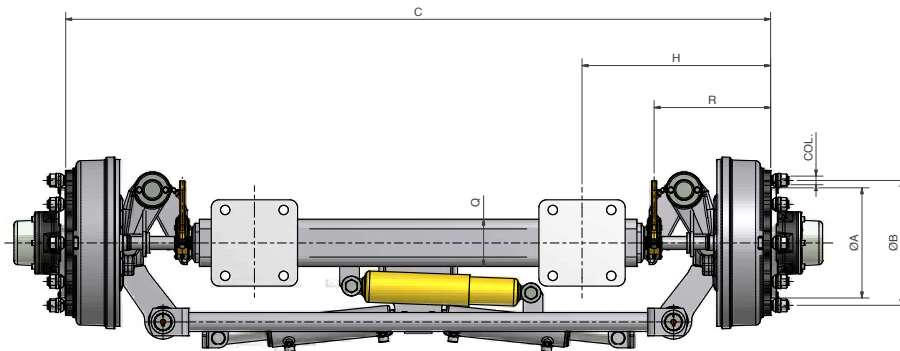
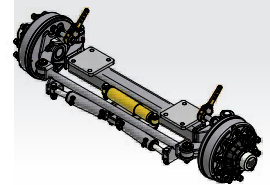

CODICE Code	Q QUADRO Square (mm)	PORTATA - Capacity (kg)		H SBALZO Overhang (mm)	ATTACCO - Fitting		
		25 km/h	40 km/h		NC	A	B
HA9006675	90	9000	8500	390	6 M18	160	205
HA9008675	90	9000	8500	390	8 M18	220	275
HA9008880	90	10000	9500	350	8 M20	220	275
HA0008880	100	10000	9500	475	8 M20	220	275
HA0008899	100	10500	10000	450	8 M20	220	275
HA0010880	100	10000	9500	475	10 M22	280	335
HA0010899	100	10500	10000	450	10 M22	280	335
HA1110899	110	10500	10000	550	10 M22	280	335
HA1208899	120x12	10500	10000	470	8 M20	220	275

Sterzata comandata

Tra la gamma di assali sterzanti TVZ è disponibile anche un assale studiato per la sterzata comandata. L'assale con sistema di sterzata comandata idraulicamente offre i seguenti vantaggi:

- conferisce una maggiore guidabilità del veicolo in entrambi i sensi di marcia, senza dover bloccare la sterzata in retromarcia;
- permette un minor consumo dei pneumatici dovuto alla riduzione degli strisciamenti;
- permette raggi di sterzata minori e quindi facilita le manovre;
- conferisce una maggiore stabilità al veicolo.

Forced steering

An axle designed for forced steering is also available within the T.V.Z. steering axle range. The axle with an hydraulically operated forced steering system offers the following advantages:

- provides for an easier vehicle drive in both running directions without having to lock the steering in reverse gear;
- allows less tyre wear thanks to the reduction of dragging;
- allows a smaller steering radius, therefore facilitating manoeuvring;
- provides for a vehicle greater stability.

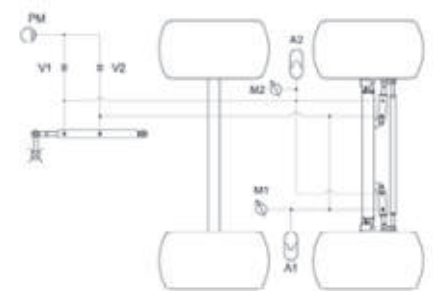

Impianto per Tandem
Tandem scheme

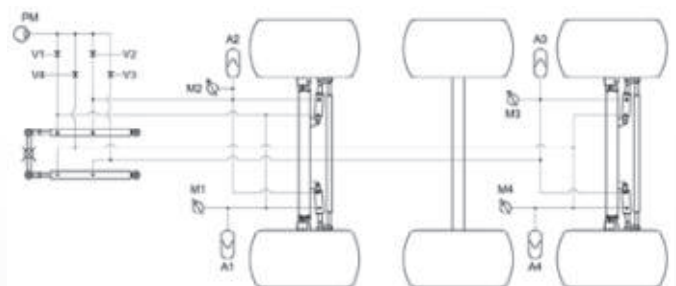

Impianto per Tridem
Tridem scheme

LEGENDA - LEGEND		
A1, A2, A3, A4	ACCUMULATORI A GAS	INERT GAS ACCUMULATOR
M1, M2, M3, M4	MANOMETRI DI CONTROLLO	PRESSURE GAUGE
V1, V2, V3, V4	VALVOLE A SFERA	TAP
PM	POMPA DI ALIMENTAZIONE	FEEDING PUMP



Assali sterzanti comandati SQR _ SQR forced steering axles

25-40 km/h



QUADRI - SQUARES

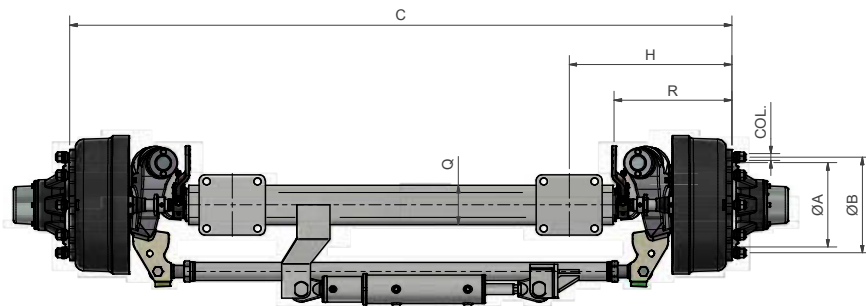
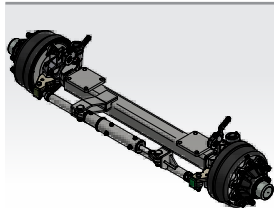

CODICE Code	Q QUADRO Square (mm)	PORTATA - Capacity (kg)		H SBALZO Overhang (mm)	ATTACCO - Fitting		
		25 km/h	40 km/h		NC	A	B
XA0008880	100	10000	9500	475	8 M20	220	275
XA0010880	100	10000	9500	475	10 M22	280	335
XA0008899	100	12500	11500	380	8 M20	220	275
XA0010899	100	12500	11500	380	10 M22	280	335
XA1110991	110	13000	12000	470	10 M22	280	335
XA1208899	120x12	12500	11500	390	8 M20	220	275
XA1210899	120x12	12500	11500	390	10 M22	280	335
XA1308899	130x14	12500	11500	530	8 M20	220	275
XA1310899	130x14	12500	11500	530	10 M22	280	335
XA1310991	130x14	13000	12000	510	10 M22	280	335
XA1310994	130x14	13000	12000	510	10 M22	280	335

Sterzata comandata

Tra la gamma di assali sterzanti TVZ è disponibile anche un assale studiato per la sterzata comandata. L'assale con sistema di sterzata comandata idraulicamente offre i seguenti vantaggi:

- conferisce una maggiore guidabilità del veicolo in entrambi i sensi di marcia, senza dover bloccare la sterzata in retromarcia;
- permette un minor consumo dei pneumatici dovuto alla riduzione degli strisciamenti;
- permette raggi di sterzata minori e quindi facilita le manovre;
- conferisce una maggiore stabilità al veicolo.

Forced steering

An axle designed for forced steering is also available within the TVZ steering axle range. The axle with an hydraulically operated forced steering system offers the following advantages:

- provides for an easier vehicle drive in both running directions without having to lock the steering in reverse gear;
- allows less tyre wear thanks to the reduction of dragging;
- allows a smaller steering radius, therefore facilitating manoeuvring;
- provides for a vehicle greater stability.

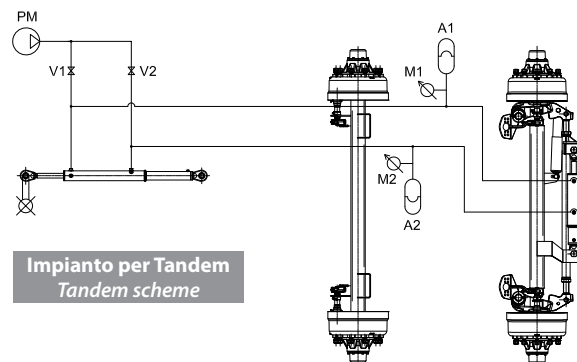

Impianto per Tandem
Tandem scheme

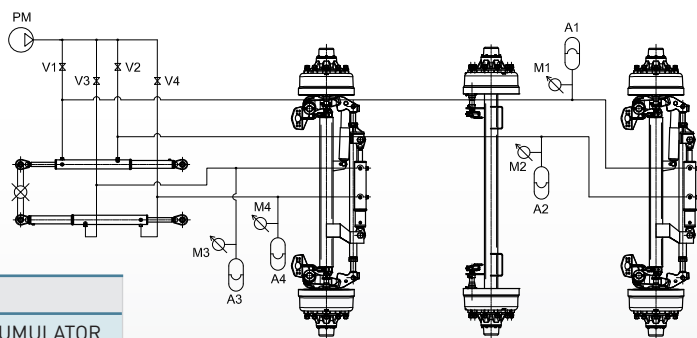

Impianto per Tridem
Tridem scheme

LEGENDA - LEGEND

A1, A2, A3, A4	ACCUMULATORI A GAS	INERT GAS ACCUMULATOR
M1, M2, M3, M4	MANOMETRI DI CONTROLLO	PRESSURE GAUGE
V1, V2, V3, V4	VALVOLE A SFERA	TAP
PM	POMPA DI ALIMENTAZIONE	FEEDING PUMP

Assali sterzanti comandati SQS _ SQS forced steering axles

25-40 km/h

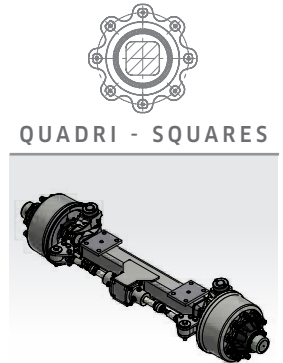
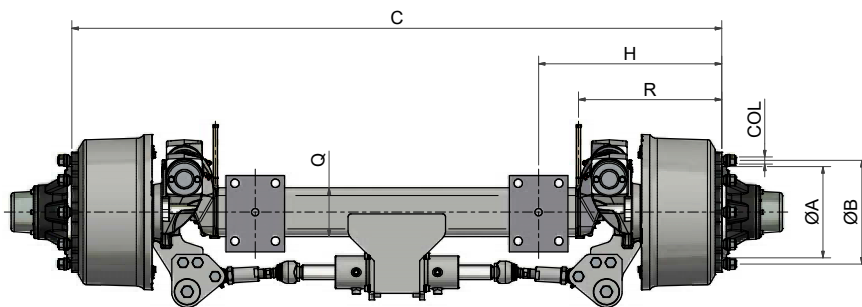

CODICE Code	Q QUADRO Square (mm)	PORTATA - Capacity (kg)		H SBALZO Overhang (mm)	ATTACCO - Fitting		
		25 km/h	40 km/h		NC	A	B
VA1510994	150x14	14500	14000	610	10 M22	280	335
VA1510998	150x16	16000	16000	600	10 M22	280	335

Sterzata comandata

Tra la gamma di assali sterzanti TVZ è disponibile anche un assale studiato per la sterzata comandata. L'assale con sistema di sterzata comandata idraulicamente offre i seguenti vantaggi:

- conferisce una maggiore guidabilità del veicolo in entrambi i sensi di marcia, senza dover bloccare la sterzata in retromarcia;
- permette un minor consumo dei pneumatici dovuto alla riduzione degli strisciamenti;
- permette raggi di sterzata minori e quindi facilita le manovre;
- conferisce una maggiore stabilità al veicolo.

Forced steering

An axle designed for forced steering is also available within the TVZ steering axle range. The axle with an hydraulically operated forced steering system offers the following advantages:

- provides for an easier vehicle drive in both running directions without having to lock the steering in reverse gear;
- allows less tyre wear thanks to the reduction of dragging;
- allows a smaller steering radius, therefore facilitating manoeuvring;
- provides for a vehicle greater stability.

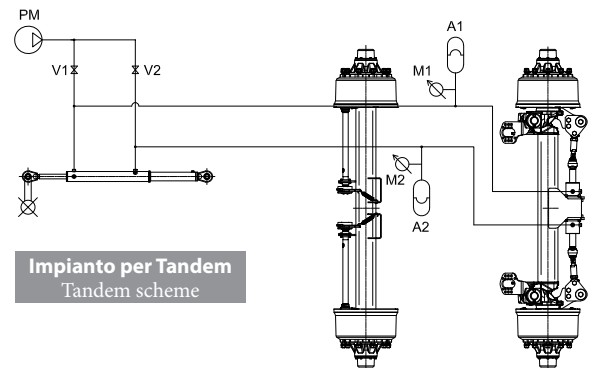

Impianto per Tandem
Tandem scheme

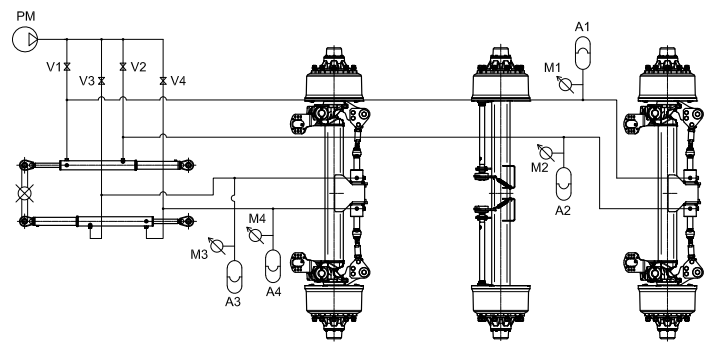

Impianto per Tridem
Tridem scheme

LEGENDA - LEGEND		
A1, A2, A3, A4	ACCUMULATORI A GAS	INERT GAS ACCUMULATOR
M1, M2, M3, M4	MANOMETRI DI CONTROLLO	PRESSURE GAUGE
V1, V2, V3, V4	VALVOLE A SFERA	TAP
PM	POMPA DI ALIMENTAZIONE	FEEDING PUMP

Bilancino _ Compensator

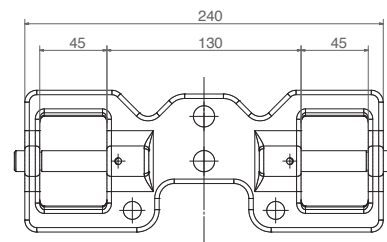
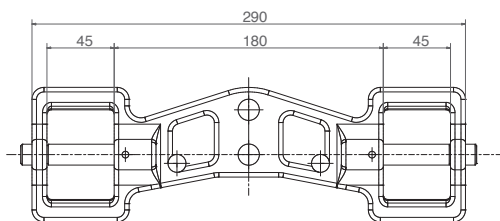
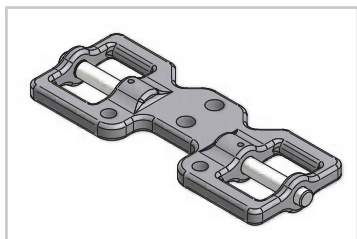

Ingrassatore _ Grease nipple

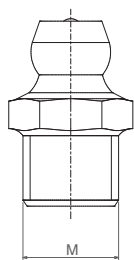
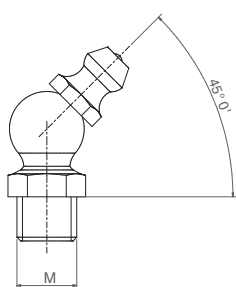
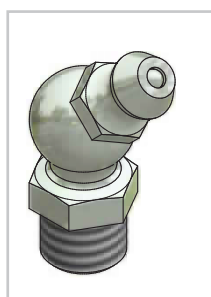

Tenuta parafango _ Mud guard

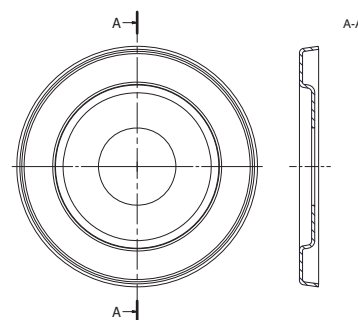
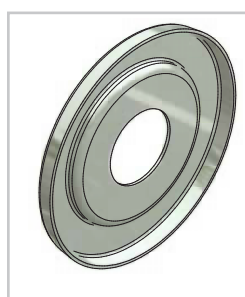

Correttore di sterzata _ Steering corrector

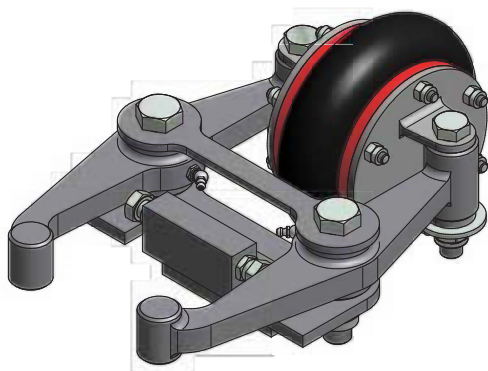

Tenute con parapolvere _ Seals with dust cover

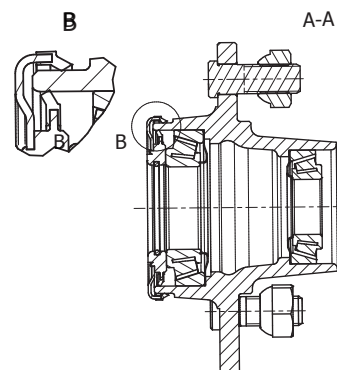
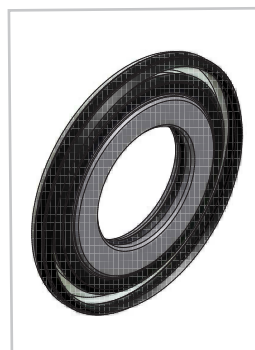

Sensore ABS e leve automatiche _ ABS sensor and automatic slack adjusters

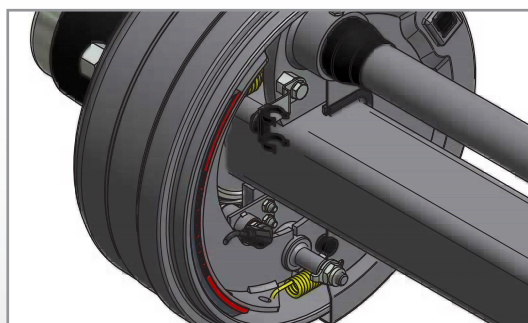

I freni omologati ECE-R13 sono disponibili leve freno autoregistranti e anche con sensore ABS.

The brakes approved ECE-R13 are available with automatic slack adjusters and also with ABS sensor.

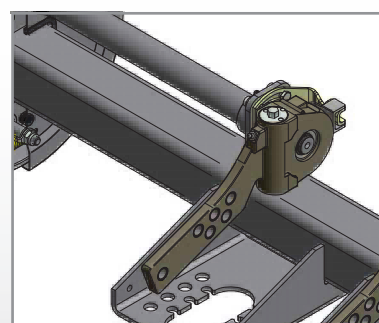

Bielementi frenanti _ Spring brakes actuators

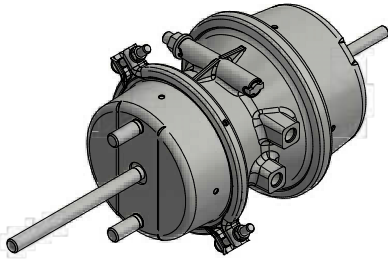

CODICE Code	SERVIZIO - Service		PARCHEGGIO - Parking	
	TIPO Type	CORSA / Stroke (mm)	TIPO Type	CORSA / Stroke (mm)
TS1624	16"	75	24"	75
TS2024	20"	64	24"	64
TS2030	20"	75	30"	75
TS2424	24"	64	24"	64
TS2430	24"	75	30"	75
TS3030	30"	64	30"	64

Brake chambers e supporti _ Brake chambers and supports

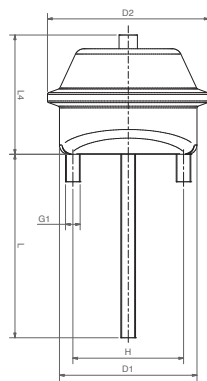
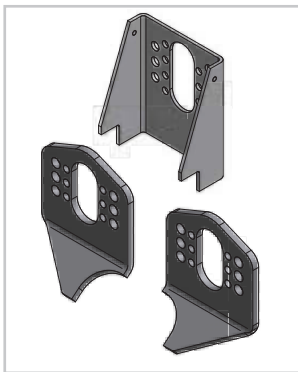

CODICE Code	DATI TECNICI - Technical data						
	TIPO Type	D1 (mm)	D2 (mm)	G1 (mm)	H (mm)	L4 (mm)	L (mm)
BC09	9"	114	133	M12x1,75	76,2	110	185
BC12	12"	121	145	M12x1,75	76,2	120	200
BC16	16"	138	163	M12x1,75	76,2	130	200
BC20	20"	150	176	M16x1,5	120,7	130	200
BC24	24"	161	185	M16x1,5	120,7	130	200
BC30	30"	182	208	M16x1,5	120,7	140	200

Cilindri pneumatico idraulici _ Dual supply actuators



CODICE Code	AZIONAMENTO Actuation		FORZA GENERATA Generated force	
	PNEUMATICO Air	IDRAULICO Hydr.	6,5 bar ARIA / Air	100 bar IDR. / Hydr.
PH1225	12"	25 mm	500 daN	490 daN
PH2030	20"	30 mm	838 daN	707 daN
PH2435	24"	35 mm	1000 daN	960 daN

Targhetta identificativa _ Identification plate

TVZ

25 KM/H	12500	14000	10500
40 KM/H	11000	12000	10000
60 KM/H	10000	11000	9000

ECE-R13 ID1-A406I ID2-406I ID3-8829 ID4-36104413
 2015/68-30
 2015/68-40 ID1-A406I ID2-406I ID3-9810 ID4-36108116

A13010898406I001
V-1301225

TUEV-40 36101515
UTAC-25 13/09283

PORTATA (kg)
Capacity (kg)

CODICE TVZ
TVZ code

LOTTO DI PRODUZIONE
Production lot

VERBALI FRENO
Brake test reports

Altre opzioni disponibili _ Other options available

- Cavallino - Camber
- Verniciatura antiruggine - Antirust paint
- Verniciatura di finitura - Finishing paint

Per altre opzioni prego contattare il nostro ufficio commerciale
For other options please take contact with our sales office





SOSPENSIONI BOGIE

bogie suspensions

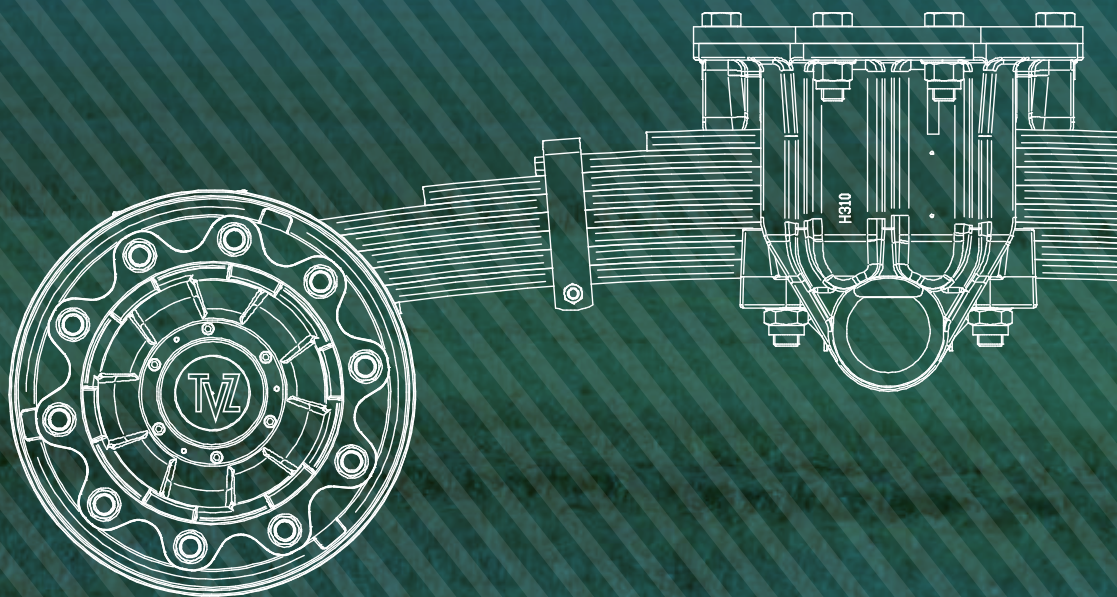



Sospensioni bogie _ Bogie suspensions

I BOGIE

La sospensione bogie è un tipo di sospensione meccanica oscillante nel senso di marcia, con balestre multi foglia, utilizzata in agricoltura per equipaggiare veicoli tandem. Il vantaggio principale è che può viaggiare su terreni particolarmente sconnessi, grazie alla sua possibilità di compiere ampie oscillazioni, adattandosi alle asperità.

GAMMA BOGIE TVZ

- Bogie modello 1 con portate da 06.0 a 13.0 Ton. Con passi da 760 a 1300 mm.
- Bogie modello 1B con portate da 11.5 a 16.0 Ton. Con passi da 900 a 1320 mm.
- Bogie modello 2 con portate da 15.5 a 17.5 Ton. Con passi da 1200 a 1480 mm.
- Bogie modello 3 con portate da 17.5 a 21.5 Ton. Con passi da 1360 a 1480 mm.
- Bogie modello 4 con portate da 18.5 a 22.0 Ton. Con passi da 1500 a 1700 mm.
- Bogie modello 5 con portate da 23.0 a 28.0 Ton. Con passi da 1500 a 1820 mm.

FORNITURA

I bogie TVZ vengono forniti assemblati con gli assali entrambi fissi o fisso più sterzante, pronti per essere fissati al telaio del veicolo. Su richiesta i bogie possono essere forniti smontati. TVZ può fornire su richiesta le contropiastre complete di bulloneria per il fissaggio del bogie al telaio. I bogie possono essere forniti con assetto normale (gli assali sono sotto le balestre) o con assetto ribassato (gli assali sono sopra le balestre).

MONTAGGIO DEL BOGIE

Per assicurare la massima affidabilità, durata e sicurezza di tutti i componenti del veicolo è importante che i bogie vengano installati correttamente. L'allineamento del bogie è eseguito dal costruttore del veicolo, gli assali del bogie devono risultare paralleli tra di loro e paralleli con il trattore, questo garantisce un buon controllo del veicolo e una vita maggiore dei pneumatici. Per eventuali mal funzionamenti o danni al bogie, agli assali, ai freni o ai pneumatici, derivanti dal montaggio non corretto del bogie è responsabile solo l'installatore.

BOGIES

The bogie suspension is a type of oscillating mechanical suspension with multi-leaf springs which is used in agriculture to fit tandem vehicles. Its main advantage is that vehicles can travel across particularly rough terrain, thanks to the wide oscillation movements which adapt to the roughness of the ground.

RANGE

- Bogie model 1 with capacity ranging from 06.0 to 13.0 Tonnes with wheel base from 760 to 1,300 mm.
- Bogie model 1B with capacity ranging from 11.5 to 16 Tonnes with wheel base from 900 to 1,320 mm.
- Bogie model 2 with capacity ranging from 15.5 to 17.5 Tonnes with wheel base from 1,200 to 1,480 mm.
- Bogie model 3 with capacity ranging from 17.5 to 21.5 Tonnes with wheel base from 1,360 to 1,480 mm.
- Bogie model 4 with capacity ranging from 18.5 to 22.0 Tonnes with wheel base from 1,500 to 1,700 mm.
- Bogie model 5 with capacity ranging from 23.0 to 28.0 Tonnes with wheel base from 1,500 to 1,820 mm.

SUPPLY

The T.V.Z. bogies are either supplied with both axles fixed or with fixed and steering axles, ready to be fitted to the vehicle frame. Upon request, the bogies can also be supplied not assembled. T.V.Z. can provide the counter plates with bolts and nuts to fix the bogie to the frame.

The bogies can be provided in a normal arrangement (the axles under the leaf springs) or low arrangement (the axles on top of the springs).

BOGIE ASSEMBLY

The correct installation of the bogie is important to ensure maximum reliability, duration and safety of all the vehicle components. The vehicle manufacturer must align the bogie. The bogie axles must be parallel with each other and the tractor. This guarantees good vehicle control and a longer life for the tyres. In case of any failures or damage to the bogie, axles, brakes or tyres due to an incorrect assembly of the bogie, the installer bears full responsibility.



Mod. 1

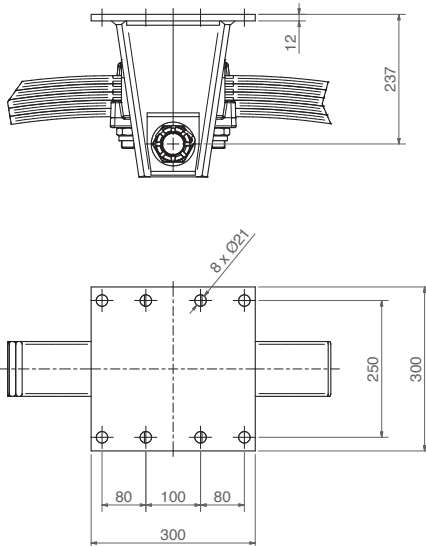

Mod. 1b

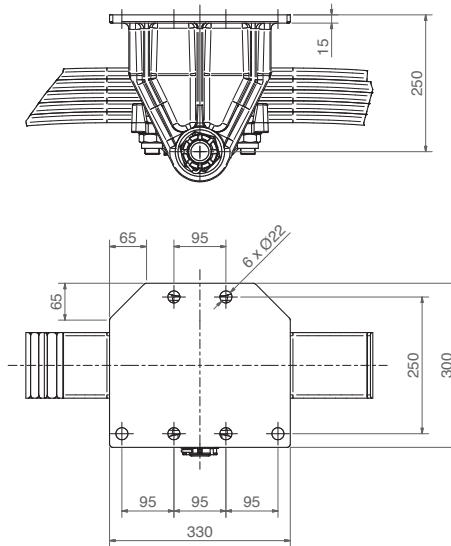

Mod. 2

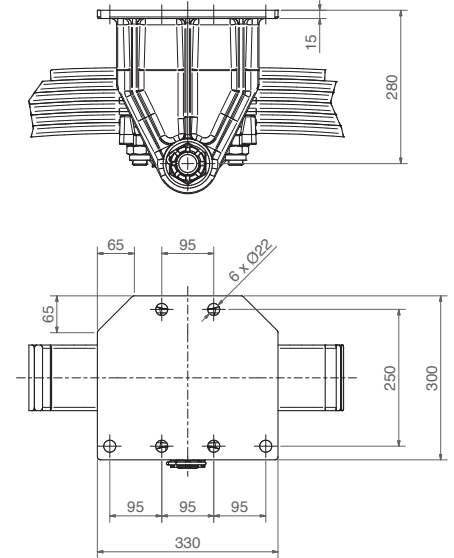

Mod. 3

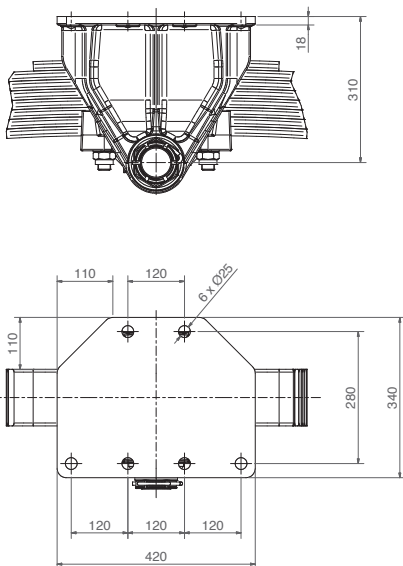

Mod. 4

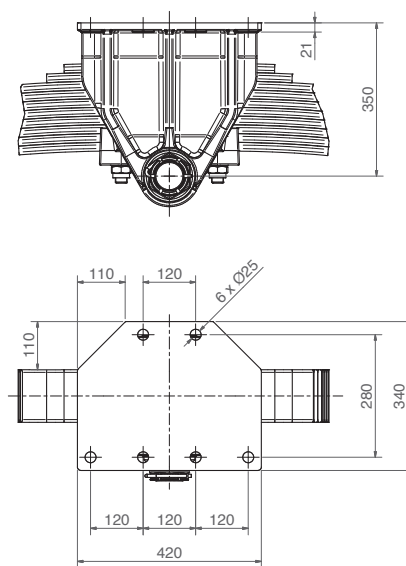

Mod. 5

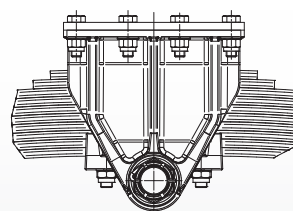
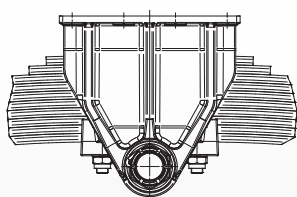
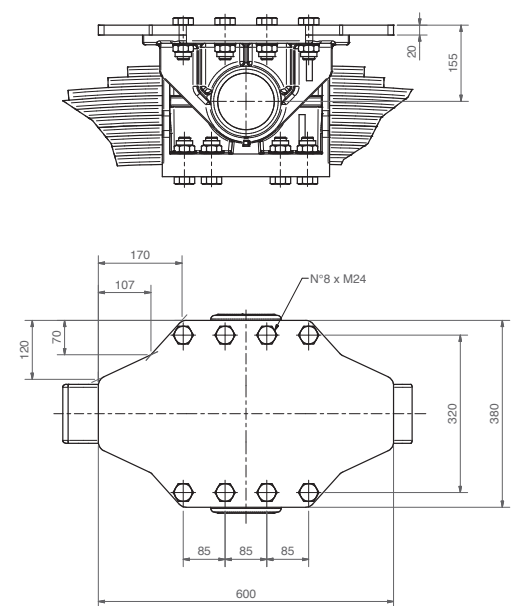

I supporti possono essere forniti:

- Forati
- Forati con contropiastra completa di bulloneria

The brackets can be delivered:

- With holes
- With holes and counterplate including bolts and nuts

Mod. 1 - 6/13 ton.

STANDARD

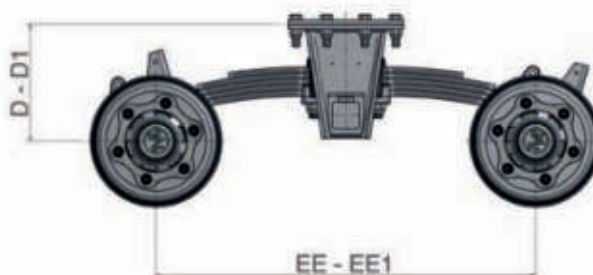

C	EE	LF		Q.60			Q.70			Q.80			Q.90			
				D	D1	EE1	D	D1	EE1	D	D1	EE1	D	D1	EE1	
(kg)	(mm)			(mm)	(mm)	(mm)	(mm)	(mm)	(mm)	(mm)	(mm)	(mm)	(mm)	(mm)	(mm)	
6000	760	L100-BT03	3x15 (3LM)	260	244	765	266	250	763							
8000	920	L100-B805	4x15 (3LM)				302	281	884	307	286	881				
8500	1000	L100-B803	5x15 (3LM)				302	277	988	307	282	985				
10500	1300	L100-B800	3x15 3x20 (3LM)							307	268	1294	312	273	1292	
11500	1200	L100-B801	3x15 3x20 (3LM)							307	276	1182	312	281	1179	
12000	1000	L100-BT01	5x18 (3LM)							305	278	990	310	283	987	
13000	1100	L100-B802	3x15 3x20 (3LM)							307	281	1079	312	286	1076	

RIBASSATO / UNDERSLUNG

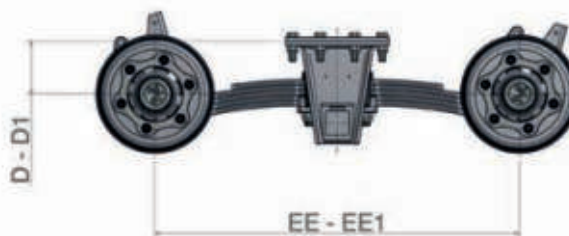

C	EE	LF		Q.60			Q.70			Q.80			Q.90			
				D	D1	EE1	D	D1	EE1	D	D1	EE1	D	D1	EE1	
(kg)	(mm)			(mm)	(mm)	(mm)	(mm)	(mm)	(mm)	(mm)	(mm)	(mm)	(mm)	(mm)	(mm)	
6000	760	L100-BT03	3x15 (3LM)	128	112	800	122	106	802							
8000	920	L100-B805	4x15 (3LM)				157	136	918	152	131	922				
8500	1000	L100-B803	5x15 (3LM)				157	132	1052	152	127	1055				
10500	1300	L100-B800	3x15 3x20 (3LM)							152	113	1346	147	108	1348	
11500	1200	L100-B801	3x15 3x20 (3LM)							152	121	1238	147	116	1241	
12000	1000	L100-BT01	5x18 (3LM)							144	117	1060	139	112	1063	
13000	1100	L100-B802	3x15 3x20 (3LM)							152	126	1141	147	121	1144	

C	PORTATA DI DUE BALESTRE	CAPACITY OF TWO SPRINGS	D	ALTEZZA A VUOTO	HEIGHT WHEN EMPTY
EE	PASSO	WHEEL BASE	D1	ALTEZZA SOTTO CARICO	HEIGHT WHEN LOADED
EE1	PASSO A VUOTO	WHEEL BASE WHEN EMPTY	Q	LATO QUADRO ASSALE	AXLE SQUARE BEAM
LF	TIPO DI BALESTRA	LEAF SPRING			

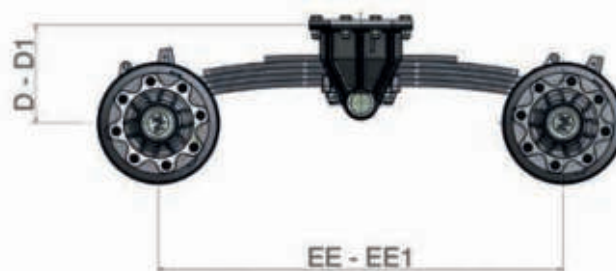
Sospensioni bogie _ Bogie suspensions
Mod. 1b - 11,5/16 ton.
STANDARD

C	EE	LF		Q.80			Q.90			Q.100		
				D	D1	EE1	D	D1	EE1	D	D1	EE1
(kg)	(mm)			(mm)	(mm)	(mm)	(mm)	(mm)	(mm)	(mm)	(mm)	
11500	1200	L100-B801	3x15 3x20 (3 LM)	315	284	1182	320	289	1179			
13500	1320	L120-B551	5x20 (3 LM)	310	275	1293	315	280	1291			
15000	1200	L120-B551	5x20 (3 LM)				303	275	1174	308	280	1171
16000	900	L100-B695	7x16 (3 LM)				300	283	867	305	287	865

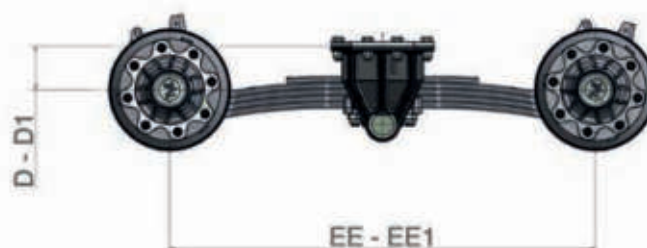
RIBASSATO / UNDERSLUNG

C	EE	LF		Q.80			Q.90			Q.100		
				D	D1	EE1	D	D1	EE1	D	D1	EE1
(kg)	(mm)			(mm)	(mm)	(mm)	(mm)	(mm)	(mm)	(mm)	(mm)	
11500	1200	L100-B801	3x15 3x20 (3 LM)	160	129	1238	155	124	1241			
13500	1320	L120-B551	5x20 (3 LM)	140	105	1347	135	100	1349			
15000	1200	L120-B551	5x20 (3 LM)				123	95	1226	118	90	1229
16000	900	L100-B695	7x16 (3 LM)				132	115	933	127	109	935

C	PORTATA DI DUE BALESTRE	CAPACITY OF TWO SPRINGS
EE	PASSO	WHEEL BASE
EE1	PASSO A VUOTO	WHEEL BASE WHEN EMPTY
LF	TIPO DI BALESTRA	LEAF SPRING
D	ALTEZZA A VUOTO	HEIGHT WHEN EMPTY
D1	ALTEZZA SOTTO CARICO	HEIGHT WHEN LOADED
Q	LATO QUADRO ASSALE	AXLE SQUARE BEAM

Mod. 2 - 15,5/17,5 ton.

STANDARD

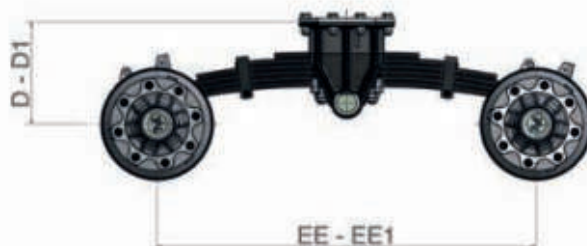

C	EE	LF		Q=90			Q=100		
				D	D1	EE1	D	D1	EE1
(kg)	(mm)			(mm)	(mm)	(mm)	(mm)	(mm)	(mm)
15500	1360	L120-B523	6x20 (3LM)	360	323	1328	365	328	1325
16500	1200	L120-B560	7x20 (3LM)	328	307	1178	333	312	1177
16500	1360	L120-B541	7x20 (3LM)	345	311	1345	350	316	1342
16500	1480	L120-B524	7x20 (3LM)	360	315	1451	365	320	1449
17500	1240	L120-B523	6x20 (3LM)	345	315	1211	350	320	1209
17500	1360	L120-B556	7x20 (4LM)	345	309	1332	350	314	1330

RIBASSATO / UNDERSLUNG

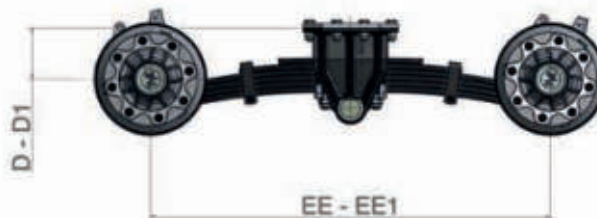

C	EE	LF		Q=90			Q=100		
				D	D1	EE1	D	D1	EE1
(kg)	(mm)			(mm)	(mm)	(mm)	(mm)	(mm)	(mm)
15500	1360	L120-B523	6x20 (3LM)	180	143	1392	175	138	1395
16500	1200	L120-B560	7x20 (3LM)	148	127	1222	143	122	1223
16500	1360	L120-B541	7x20 (3LM)	165	131	1395	160	126	1398
16500	1480	L120-B524	7x20 (3LM)	180	135	1509	175	130	1511
17500	1240	L120-B523	6x20 (3LM)	165	135	1269	160	130	1271
17500	1360	L120-B556	7x20 (4LM)	165	129	1388	160	124	1390

C	PORTATA DI DUE BALESTRE	CAPACITY OF TWO SPRINGS
EE	PASSO	WHEEL BASE
EE1	PASSO A VUOTO	WHEEL BASE WHEN EMPTY
LF	TIPO DI BALESTRA	LEAF SPRING
D	ALTEZZA A VUOTO	HEIGHT WHEN EMPTY
D1	ALTEZZA SOTTO CARICO	HEIGHT WHEN LOADED
Q	LATO QUADRO ASSALE	AXLE SQUARE BEAM

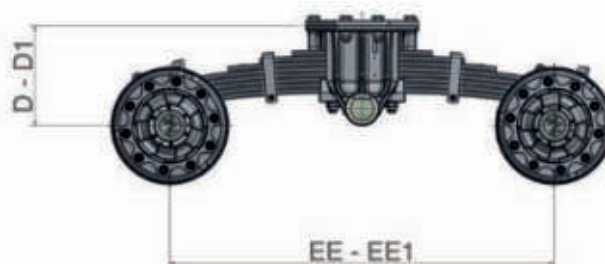
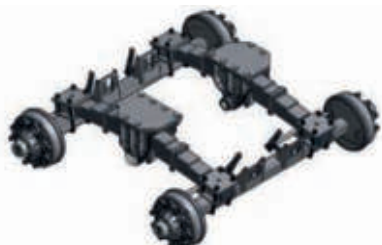
STANDARD

C	EE	LF		Q=100			Q=110			Q=130		
				D	D1	EE1	D	D1	EE1	D	D1	EE1
(kg)	(mm)			(mm)	(mm)	(mm)	(mm)	(mm)	(mm)	(mm)	(mm)	(mm)
17500	1450	L120-B228	7x20 (4LM)	383	343	1422	388	348	1420			
18500	1480	L120-B554	4x20 3x22 (4LM)	378	338	1455	383	343	1454			
19000	1360	L120-B556	7x20 (4LM)	378	343	1330	383	348	1328			
19500	1480	L120-B533	8x20 (4LM)	378	336	1455	383	341	1453	391	349	1451
21500	1360	L120-B549	8x20 (4LM)	378	344	1330	383	349	1328	391	357	1326

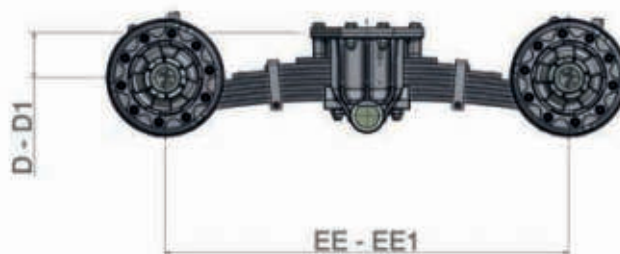
RIBASSATO / UNDERSLUNG

C	EE	LF		Q=100			Q=110			Q=130		
				D	D1	EE1	D	D1	EE1	D	D1	EE1
(kg)	(mm)			(mm)	(mm)	(mm)	(mm)	(mm)	(mm)	(mm)	(mm)	(mm)
17500	1450	L120-B228	7x20 (4LM)	173	133	1478	168	128	1480			
18500	1480	L120-B554	4x20 3x22 (4LM)	168	128	1505	163	123	1506			
19000	1360	L120-B556	7x20 (4LM)	168	133	1390	163	128	1392			
19500	1480	L120-B533	8x20 (4LM)	168	126	1505	163	121	1507	154	112	1515
21500	1360	L120-B549	8x20 (4LM)	168	134	1390	163	129	1392	154	120	1400

C	PORTATA DI DUE BALESTRE	CAPACITY OF TWO SPRINGS
EE	PASSO	WHEEL BASE
EE1	PASSO A VUOTO	WHEEL BASE WHEN EMPTY
LF	TIPO DI BALESTRA	LEAF SPRING
D	ALTEZZA A VUOTO	HEIGHT WHEN EMPTY
D1	ALTEZZA SOTTO CARICO	HEIGHT WHEN LOADED
Q	LATO QUADRO ASSALE	AXLE SQUARE BEAM

Mod. 4 - 18,5/22 ton.

STANDARD

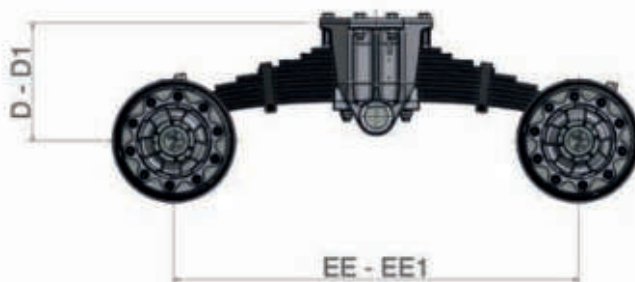

C (kg)	EE (mm)	LF		Q=100			Q=110			Q=130		
				D (mm)	D1 (mm)	EE1 (mm)	D (mm)	D1 (mm)	EE1 (mm)	D (mm)	D1 (mm)	EE1 (mm)
18500	1700	L120-B548	9x20 (4LM)	463	404	1661	468	409	1658			
20000	1600	L120-B548	9x20 (4LM)	448	396	1564	453	401	1561			
20500	1700	L120-B526	10x20 (4LM)	451	390	1687	456	395	1685	462	401	1683
21500	1500	L120-B542	9x20 (4LM)	438	390	1511	443	395	1508	451	403	1505
22000	1500	L120-B278	10x20 (4LM)	438	393	1511	443	398	1508	451	406	1505
22000	1600	L120-B526	10x20 (4LM)	438	385	1590	443	390	1587	451	398	1584

RIBASSATO / UNDERSLUNG

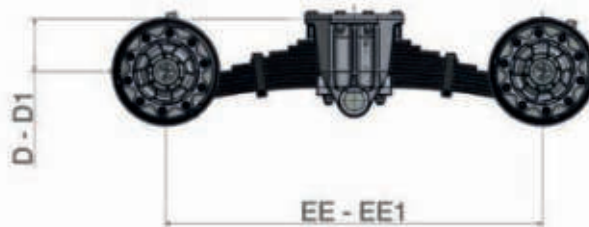

C (kg)	EE (mm)	LF		Q=100			Q=110			Q=130		
				D (mm)	D1 (mm)	EE1 (mm)	D (mm)	D1 (mm)	EE1 (mm)	D (mm)	D1 (mm)	EE1 (mm)
18500	1700	L120-B548	9x20 (4LM)	253	194	1739	248	189	1742			
20000	1600	L120-B548	9x20 (4LM)	238	186	1636	233	181	1639			
20500	1700	L120-B526	10x20 (4LM)	241	180	1753	236	175	1755	224	163	1761
21500	1500	L120-B542	9x20 (4LM)	228	180	1575	223	175	1578	214	166	1587
22000	1500	L120-B278	10x20 (4LM)	228	183	1575	223	178	1578	214	169	1587
22000	1600	L120-B526	10x20 (4LM)	228	175	1650	223	170	1653	214	161	1661

C	PORTATA DI DUE BALESTRE	CAPACITY OF TWO SPRINGS
EE	PASSO	WHEEL BASE
EE1	PASSO A VUOTO	WHEEL BASE WHEN EMPTY
LF	TIPO DI BALESTRA	LEAF SPRING
D	ALTEZZA A VUOTO	HEIGHT WHEN EMPTY
D1	ALTEZZA SOTTO CARICO	HEIGHT WHEN LOADED
Q	LATO QUADRO ASSALE	AXLE SQUARE BEAM

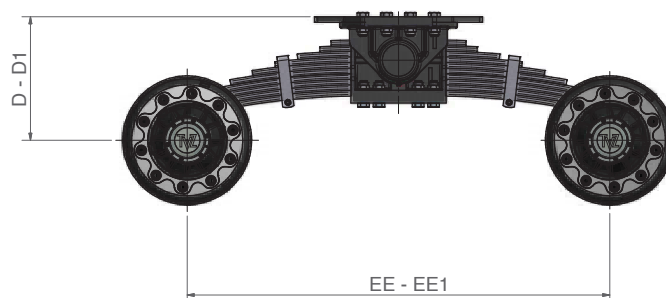
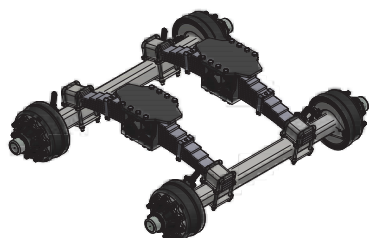
STANDARD

C	EE	LF		Q=110			Q=130			Q=150		
				D	D1	EE1	D	D1	EE1	D	D1	EE1
(kg)	(mm)			(mm)	(mm)	(mm)	(mm)	(mm)	(mm)	(mm)	(mm)	(mm)
23000	1700	L120-B525	11x20 (4LM)	466	403	1691	472	409	1687	482	419	1683
23000	1820	L120-B562	8x25 (4LM)	453	395	1819	461	403	1815	471	413	1811
24000	1500	L120-B278	10x20 (4LM)	433	383	1512	441	391	1508	451	401	1504
25000	1600	L120-B525	11x20 (4LM)	453	397	1591	461	405	1587	471	415	1583
26000	1500	L120-B532	11x20 (7LM)	453	404	1515	461	412	1511	471	422	1507
26000	1700	L120-B546	8x25 (4LM)	446	396	1691	452	402	1687	462	412	1683
26000	1820	L120-B561	9x25 (4LM)	490	440	1819	486	436	1815	496	446	1811
28000	1600	L120-B546	8x25 (4LM)	433	389	1591	441	397	1587	451	407	1583

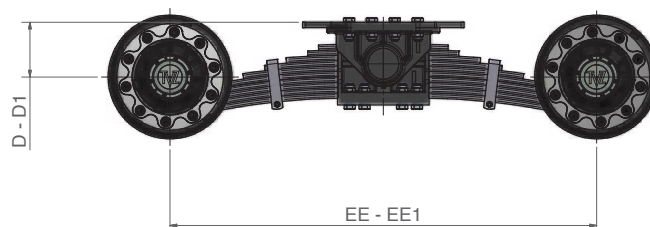
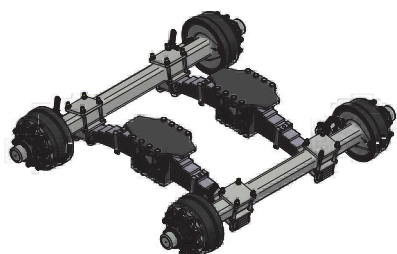
RIBASSATO / UNDERSLUNG

C	EE	LF		Q=110			Q=130			Q=150		
				D	D1	EE1	D	D1	EE1	D	D1	EE1
(kg)	(mm)			(mm)	(mm)	(mm)	(mm)	(mm)	(mm)	(mm)	(mm)	(mm)
23000	1700	L120-B525	11x20 (4LM)	246	183	1755	234	171	1761	225	162	1765
23000	1820	L120-B562	8x25 (4LM)	213	155	1884	204	146	1894	194	136	1898
24000	1500	L120-B278	10x20 (4LM)	213	163	1578	204	154	1587	194	144	1591
25000	1600	L120-B525	11x20 (4LM)	233	177	1653	224	168	1661	214	158	1665
26000	1500	L120-B532	11x20 (7LM)	173	124	1578	163	114	1583	153	104	1587
26000	1700	L120-B546	8x25 (4LM)	206	156	1755	194	144	1763	184	134	1767
26000	1820	L120-B561	9x25 (4LM)	250	200	1884	229	179	1894	219	169	1898
28000	1600	L120-B546	8x25 (4LM)	193	149	1653	184	140	1663	174	130	1667

C	PORTATA DI DUE BALESTRE	CAPACITY OF TWO SPRINGS
EE	PASSO	WHEEL BASE
EE1	PASSO A VUOTO	WHEEL BASE WHEN EMPTY
LF	TIPO DI BALESTRA	LEAF SPRING
D	ALTEZZA A VUOTO	HEIGHT WHEN EMPTY
D1	ALTEZZA SOTTO CARICO	HEIGHT WHEN LOADED
Q	LATO QUADRO ASSALE	AXLE SQUARE BEAM



Cavallotti _ U-bolts

A (mm)	B (mm)	C (mm)	M	R (mm)	CODICE Code	PESO Weight (kg)
72	120	50	M18x1,5	5	42318018	0,65
72	165	50	M18x1,5	5	42318019	0,83
72	185	50	M18x1,5	5	42318001	0,90
82	180	50	M18x1,5	5	42318010	0,90
82	195	50	M18x1,5	5	42318002	0,96
82	220	80	M22x1,5	5	42322009	1,60
92	205	50	M18x1,5	5	42318003	1,00
92	220	80	M22x1,5	5	42322019	1,65
92	230	80	M22x1,5	5	42322001	1,70
92	250	80	M22x1,5	5	42322010	1,80
102	150	50	M22x1,5	5	42322021	1,25
102	225	50	M22x1,5	5	42322013	1,70
102	240	60	M22x1,5	5	42322002	1,80
102	260	60	M22x1,5	5	42322003	1,90
112	250	60	M22x1,5	5	42322027	1,90
112	270	80	M22x1,5	5	42322004	2,00
112	320	80	M22x1,5	5	42322030	2,30

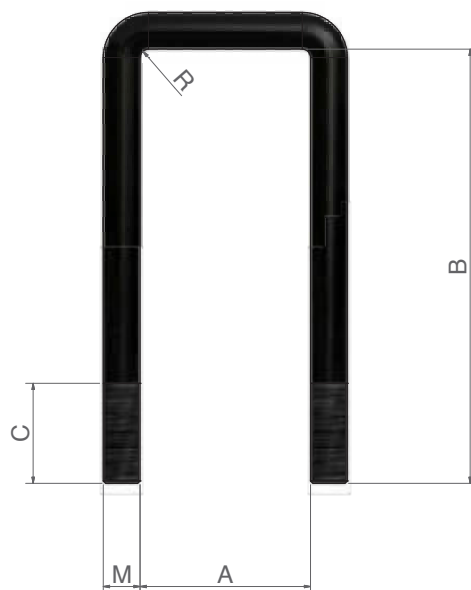

Coppie di serraggio _ Torque

TIPO DI CAVALLOTTO U Bolt type (mm)	COPIE DI SERRAGGIO Torque (Nm)
18	230 - 280
22	450 - 500
24	550 - 600
27	600 - 650





SOSPENSIONI MECCANICHE

mechanical suspensions

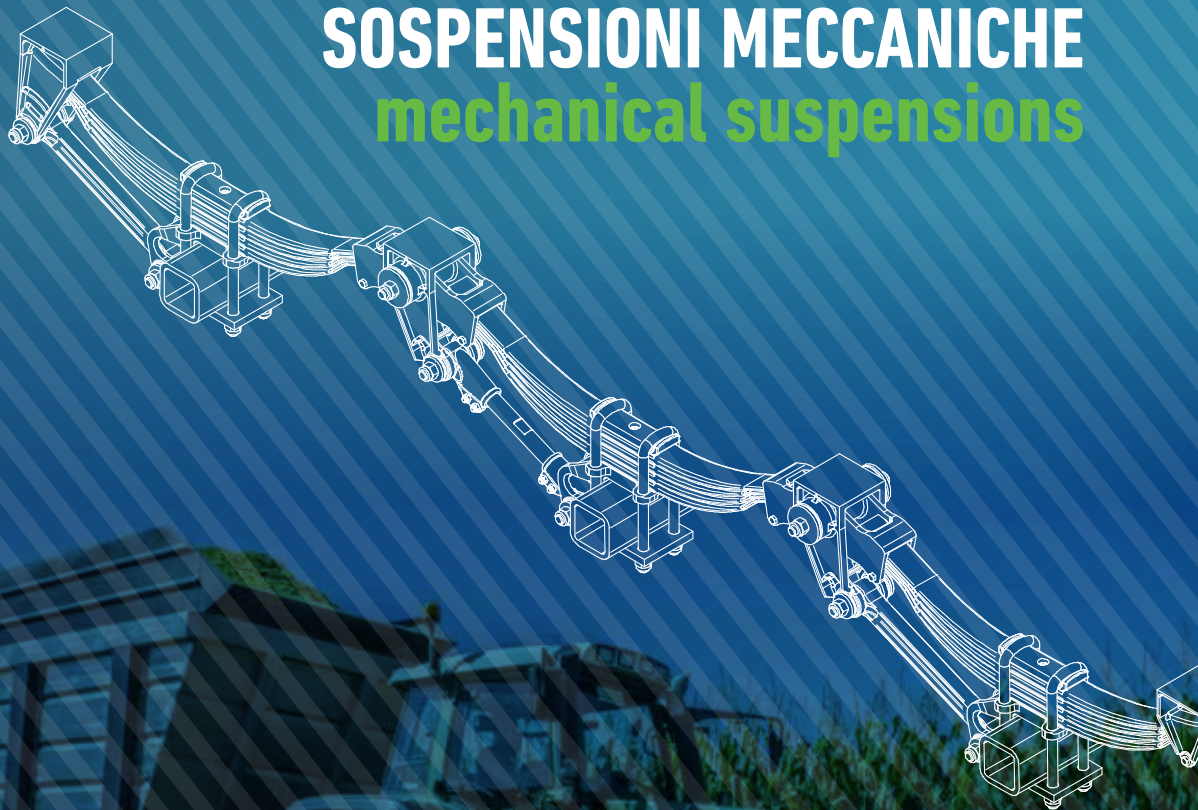



Sospensioni meccaniche _ Mechanical suspensions

LE SOSPENSIONI MECCANICHE

Sono sospensioni il cui organo elastico è una balestra, operante per flessione, composta da foglie di materiale elastico. La sospensione meccanica, data la sua notevole rigidità, è particolarmente adatta a veicoli pesanti, il sistema risulta essere particolarmente leggero, facile da installare e garantisce un buon comfort di marcia anche a velocità elevate.

GAMMA SOSPENSIONI TVZ

- Sospensioni monoasse da 5 a 12 Ton.
- Sospensioni tandem da 10 a 24 Ton.
- Sospensioni tridem da 24 a 36 Ton.
- Sospensioni quadrem da 32 a 48 Ton.
- Con passi da 990 a 1525 mm.
- Con balestre da 76, 80 o 100 mm.

IMBALLO E CONTENUTO

Le sospensioni TVZ vengono fornite smontate come kit, con i sottogruppi già montati. Il contenuto del kit comprende:

- Bilanciere centrale completo, con perno di fissaggio non chiuso.
- Tiranti fissi (su sospensioni tipo 2).
- Tiranti regolabili (su sospensioni tipo 2).
- Viti di supporto balestre montate sui supporti.
- Kit per il fissaggio degli assali sulla balestra (cavallotti, dadi, piastre).
- Attacchi per tirante sugli assali.

MONTAGGIO DEGLI ASSALI

E' estremamente importante, per evitare collassi strutturali del corpo dell'assale, che le saldature dei componenti della sospensione sugli assali siano eseguite evitando le zone di massima sollecitazione. Per assicurare la massima affidabilità, durata e sicurezza di tutti i componenti del veicolo è importante che gli assali vengano installati correttamente. L'allineamento degli assali è eseguito dal costruttore del veicolo, gli assali devono risultare paralleli tra di loro e paralleli con il trattore, questo garantisce un buon controllo del veicolo e una vita maggiore dei pneumatici. Per garantire la massima efficienza frenante e durata dei freni, ed evitare rumorosità e vibrazioni anomale, le leve freno devono avere lo stesso senso di rotazione dei pneumatici. Per eventuali mal funzionamenti o danni alle sospensioni, agli assali, ai freni o ai pneumatici, derivanti dal montaggio non corretto degli assali è responsabile solo l'installatore.

MECHANICAL SUSPENSIONS

These are suspensions with an elastic part (a leaf spring), which works by flexion and is composed of elastic leaves. Since the mechanical suspension is significantly rigid, it is particularly ideal for heavy vehicles. The system is especially light, easy to install and guarantees comfort while running even at high speed.

RANGE

- Single-axle suspensions with a weight of 5 to 12 Tonnes.
- Tandem suspensions with a weight of 10 to 24 Tonnes.
- Tridem suspensions with a weight of 24 to 36 Tonnes.
- Quadrem suspensions with a weight of 32 to 48 Tonnes.
- With wheel base from 990 to 1525 mm.
- With leaf springs from 76, 80 or 100 mm.

PACKING AND CONTENT

The T.V.Z. suspensions are supplied not assembled as a kit, with the subgroups already assembled.

The kit content includes:

- Complete central rocker arms, with fixing pin not closed.
- Fixed torque arms (on type 2 suspensions).
- Adjustable torque arms (on type 2 suspensions).
- Screws holding the leaf springs fitted on the supports.
- Kit fixing the axles onto the leaf spring (U-bolts, nuts, plates).
- Torque arm connections to the axles.

AXLE ASSEMBLY

In order to avoid the structural collapse of the axle body, it is extremely important that the welding of the suspension components on the axles do not take place in the areas of maximum stress. The correct installation of the axles is important to ensure maximum reliability, duration and safety of all the vehicle components.

The alignment of the axles is carried out by the vehicle manufacturer. The axles must be parallel with each other and with the tractor. This guarantees good vehicle control and a longer life of the tyres.

The brake levers must rotate in the same direction as the tyres to guarantee maximum braking efficiency and duration and to avoid noise and anomalous vibrations.

In case of any failure or damage to the suspensions, axles, brakes or tyres due to an incorrect assembly of the axles, the installer bears full responsibility.



Coppie di serraggio _ Torque

TIPO DI CAVALLOTTO VITI U Bolt - Screw type (mm)	COPPIE DI SERRAGGIO Torque (Nm)
18	230 - 280
22	450 - 500
24	550 - 600
27	600 - 650



Balestre _ Springs

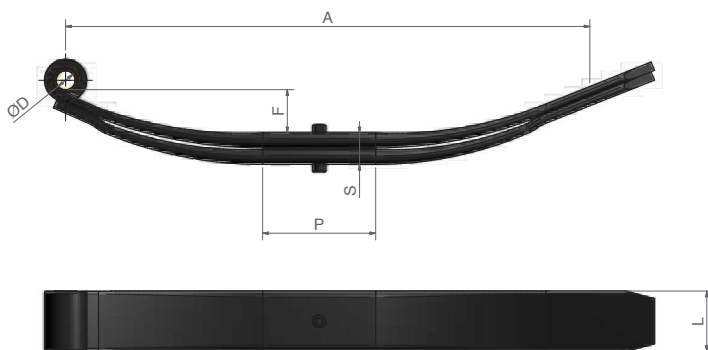

CODICE Code	PORTATA Capacity (kg)	A (mm)	D (mm)	F (mm)	L (mm)	S (mm)	P (mm)	N° DI FOGLIE N° of leaves	PESO Weight (kg)
T4188V001	2500	590	25	40	80	32	150	2	13,2
T4188V002	3500	679	25	55	80	42	150	2	17,0
T4188V003	4000	884	25	55	80	52	150	2	23,4
T4181V003	5250	915	32	55	100	54	200	2	37,9

NOTE

Le altezze delle sospensioni indicate in questo catalogo, si riferiscono alle condizioni di carico nullo o pieno carico, sempre considerando il veicolo orizzontale. Qualora la sospensione non risulti essere orizzontale, potrebbero sorgere problemi di funzionamento, occorre valutare con precisione l'inclinazione del telaio del veicolo.

NOTE

The height of suspensions indicated in this catalogue refers to the empty or full loading condition, always taking into consideration that the vehicle is in a horizontal position. If the suspension is not in a horizontal position, operating problems could arise; it is necessary to exactly verify the vehicle frame inclination.



Sospensioni meccaniche agricole _ Agricultural mechanical suspensions

MONO

Balestra - Spring 80 mm

STANDARD

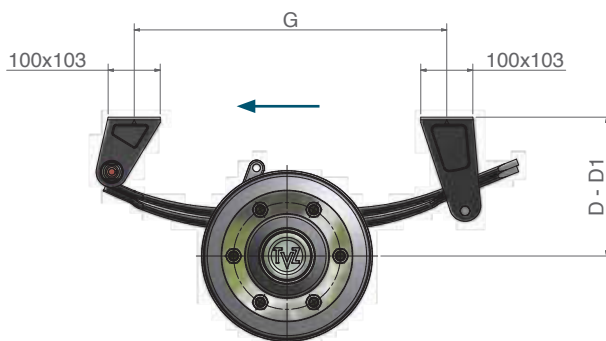

C (kg) PORTATA Capacity	G (mm)	ASSALE Axle	D (mm)	D1 (mm)	BALESTRA Spring	CODICE Code
5000	530	70	242	224	80G408	SED05N7408
		80	247	229	T4188V001	SED05N8408
7000	600	70	265	252	80G403 T4188V002	SED07N7403
		80	270	257		SED07N8403
		90	275	262		SED07N9403
8000	810	70	275	254	80G410 T4188V003	SED08N7410
		80	280	259		SED08N8410
		90	285	264		SED08N9410

RIBASSATO / UNDERSLUNG

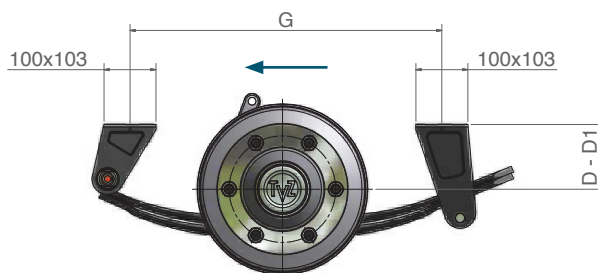
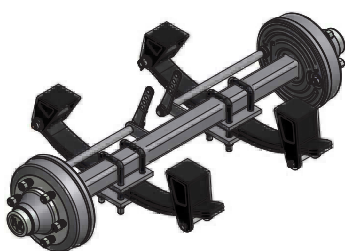

C (kg) PORTATA Capacity	G (mm)	ASSALE Axle	D (mm)	D1 (mm)	BALESTRA Spring	CODICE Code
5000	530	70	110	92	80G408	SED05R7408
		80	105	87	T4188V001	SED05R8408
7000	600	70	123	110	80G403 T4188V002	SED07R7403
		80	118	105		SED07R8403
		90	113	100		SED07R9403
8000	810	70	123	102	80G410 T4188V003	SED08R7410
		80	118	97		SED08R8410
		90	113	92		SED08R9410

C	PORTATA DI 2 BALESTRE	CAPACITY OF 2 SPRINGS
D	ALTEZZA A VUOTO	HEIGHT WHEN EMPTY
D1	ALTEZZA SOTTO CARICO	HEIGHT WHEN LOADED

Sospensioni meccaniche agricole _ Agricultural mechanical suspensions

Balestra - Spring 80 mm

TANDEM

STANDARD

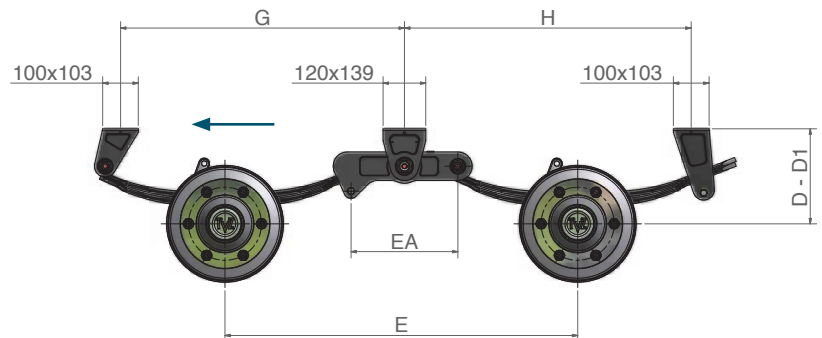

C (kg) PORTATA Capacity	E (mm)	G (mm)	H (mm)	ASSALE Axle	D (mm)	D1 (mm)	BALESTRA Spring	EA (mm)	CODICE Code
10000	910	717	725	70	242	224	80G408 T4188V001	310	TED10N7408C
				80	247	229			TED10N8408C
	1060	787	795	70	242	224		470	TED10N7408L
				80	247	229			TED10N8408L
14000	990	797	805	70	265	252	80G403 T4188V002	310	TED14N7403C
				80	270	257			TED14N8403C
				90	275	262			TED14N9403C
	1150	877	885	70	265	252		470	TED14N7403L
				80	270	257			TED14N8403L
				90	275	262			TED14N9403L
16000	1200	1007	1015	80	280	259	80G410 T4188V003	310	TED16N8410C
				90	285	264			TED16N9410C
				100	290	269			TED16NA410C
	1350	1077	1085	80	280	259		470	TED16N8410L
				90	285	264			TED16N9410L
				100	290	269			TED16NA410L

RIBASSATO / UNDERSLUNG

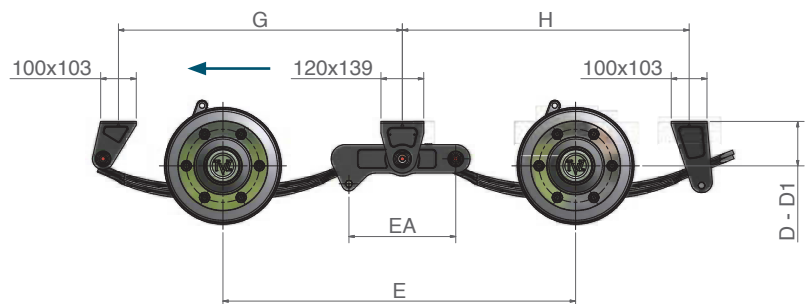
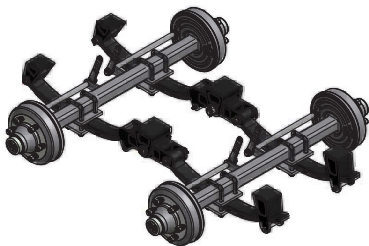

C (kg) PORTATA Capacity	E (mm)	G (mm)	H (mm)	ASSALE Axle	D (mm)	D1 (mm)	BALESTRA Spring	EA (mm)	CODICE Code
10000	910	717	725	70	110	92	80G408 T4188V001	310	TED10R7408C
				80	105	87			TED10R8408C
	1060	787	795	70	110	92		470	TED10R7408L
				80	105	87			TED10R8408L
14000	990	797	805	70	123	110	80G403 T4188V002	310	TED14R7403C
				80	118	105			TED14R8403C
				90	113	100			TED14R9403C
	1150	877	885	70	123	110		470	TED14R7403L
				80	118	105			TED14R8403L
				90	113	100			TED14R9403L
16000	1200	1007	1015	80	118	97	80G410 T4188V003	310	TED16R8410C
				90	113	92			TED16R9410C
				100	108	87			TED16RA410C
	1350	1077	1085	80	118	97		470	TED16R8410L
				90	113	92			TED16R9410L
				100	108	87			TED16RA410L

C

PORTATA DI 4 BALESTRE

CAPACITY OF 4 SPRINGS

TRIDEM

Balestra - Spring 80 mm

STANDARD

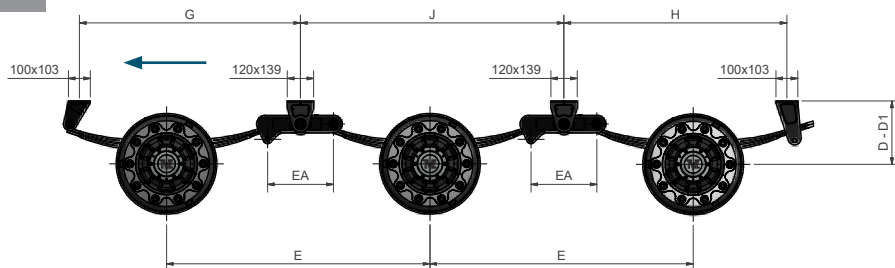
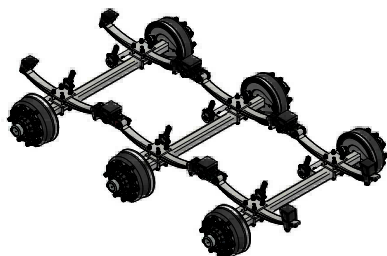

C (kg) PORTATA Capacity	E (mm)	G (mm)	J (mm)	H (mm)	ASSALE Axle	D (mm)	D1 (mm)	BALESTRA Spring	EA (mm)	CODICE Code
15000	910	717	910	725	70	242	224	80G408 T4188V001	310	KED15N7408C
					80	247	229			KED15N8408C
	1060	787	1060	795	70	242	224		470	KED15N7408L
					80	247	229			KED15N8408L
21000	990	797	990	805	70	265	252	80G403 T4188V002	310	KED21N7403C
					80	270	257			KED21N8403C
					90	275	262			KED21N9403C
	1150	877	1150	885	70	265	252		470	KED21N7403L
					80	270	257			KED21N8403L
					90	275	262			KED21N9403L
24000	1200	1007	1200	1015	80	280	259	80G410 T4188V003	310	KED24N8410C
					90	285	264			KED24N9410C
					100	290	269			KED24NA410C
	1350	1077	1350	1085	80	280	259		470	KED24N8410L
					90	285	264			KED24N9410L
					100	290	269			KED24NA410L

RIBASSATO / UNDERSLUNG

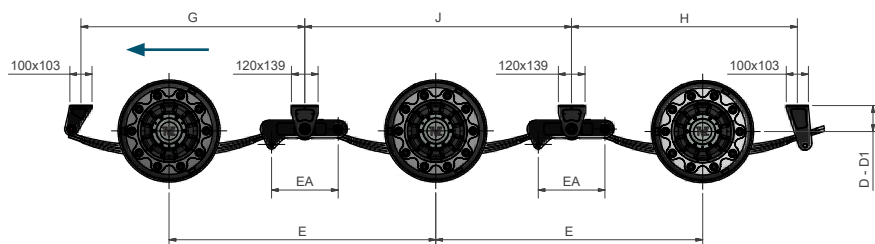
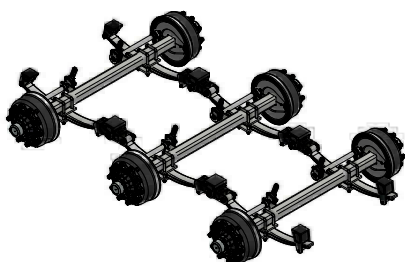

C (kg) PORTATA Capacity	E (mm)	G (mm)	J (mm)	H (mm)	ASSALE Axle	D (mm)	D1 (mm)	BALESTRA Spring	EA (mm)	CODICE Code
15000	910	717	910	725	70	110	92	80G408 T4188V001	310	KED15R7408C
					80	105	87			KED15R8408C
	1060	787	1060	795	70	110	92		470	KED15R7408L
					80	105	87			KED15R8408L
21000	990	797	990	805	70	123	110	80G403 T4188V002	310	KED21R7403C
					80	118	105			KED21R8403C
					90	113	100			KED21R9403C
	1150	877	1150	885	70	123	110		470	KED21R7403L
					80	118	105			KED21R8403L
					90	113	100			KED21R9403L
24000	1200	1007	1200	1015	80	118	97	80G410 T4188V003	310	KED24R8410C
					90	113	92			KED24R9410C
					100	108	87			KED24RA410C
	1350	1077	1350	1085	80	118	97		470	KED24R8410L
					90	113	92			KED24R9410L
					100	108	87			KED24RA410L

Sospensioni meccaniche agricole _ Agricultural mechanical suspensions

Balestra - Spring 100 mm

MONO

STANDARD

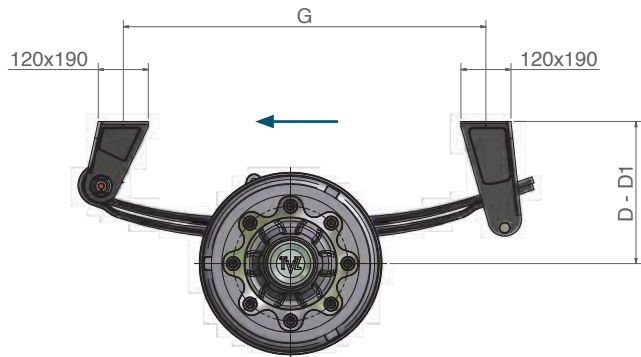

C (kg) PORTATA Capacity	G (mm)	ASSALE Axle	D (mm) (mm)	D1	BALESTRA Spring	CODICE Code
10500	870	90	341	323	100G115 T4181V003	SFE10N9115
		100	346	328		SFE10NA115
		110	351	333		SFE10NB115
		120	361	343		SFE10NC115

RIBASSATO / UNDERSLUNG

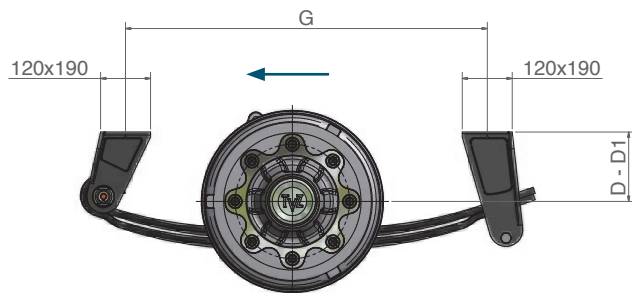

C (kg) PORTATA Capacity	G (mm)	ASSALE Axle	D (mm)	D1 (mm)	BALESTRA Spring	CODICE Code
10500	870	90	167	149	100G115 T4181V003	SFE10R9115
		100	162	144		SFE10RA115
		110	157	139		SFE10RB115
		120	147	129		SFE10RC115

C	PORTATA DI 2 BALESTRE	CAPACITY OF 2 SPRINGS
D	ALTEZZA A VUOTO	HEIGHT WHEN EMPTY
D1	ALTEZZA SOTTO CARICO	HEIGHT WHEN LOADED

TANDEM

Balestra - Spring 100 mm

STANDARD

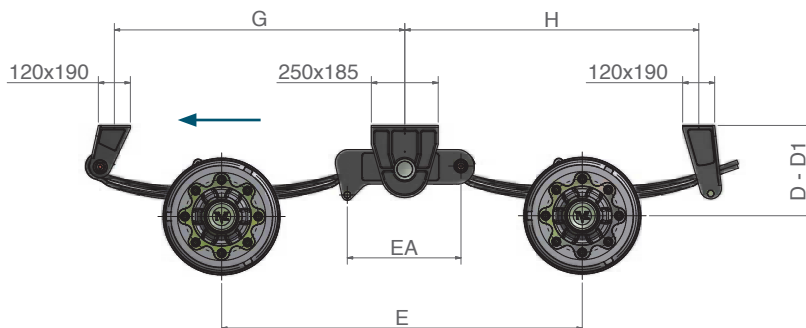

C (kg) PORTATA Capacity	E (mm)	G (mm)	H (mm)	ASSALE Axle	D (mm)	D1 (mm)	BALESTRA Spring	EA (mm)	CODICE Code
21000	1350	1087	1100	90	341	323	100G115 T4181V003	420	TFE21N9115C
				100	346	328			TFE21NA115C
				110	351	333			TFE21NB115C
				120	361	343			TFE21NC115C
	1480	1152	1165	90	341	323	100G115 T4181V003	550	TFE21N9115M
				100	346	328			TFE21NA115M
				110	351	333			TFE21NB115M
				120	361	343			TFE21NC115M
	1570	1202	1215	90	341	323	100G115 T4181V003	630	TFE21N9115L
				100	346	328			TFE21NA115L
				110	351	333			TFE21NB115L
				120	361	343			TFE21NC115L

RIBASSATO / UNDERSLUNG

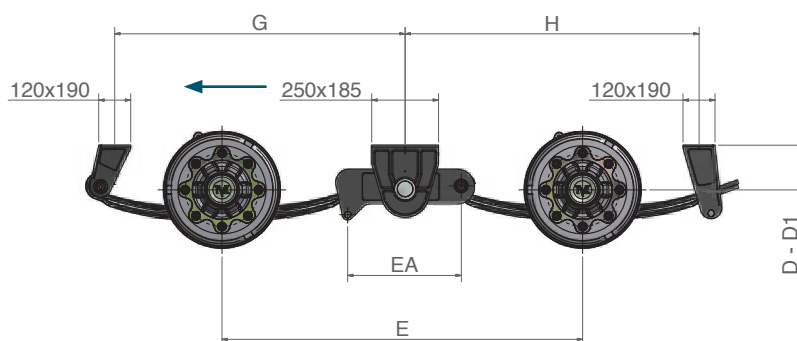
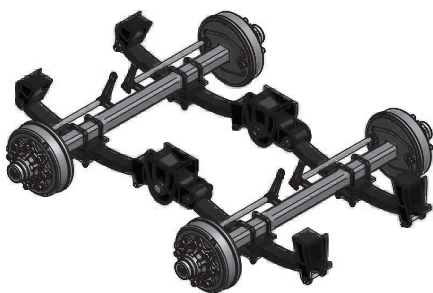

C (kg) PORTATA Capacity	E (mm)	G (mm)	H (mm)	ASSALE Axle	D (mm)	D1 (mm)	BALESTRA Spring	EA (mm)	CODICE Code
21000	1350	1087	1100	90	167	149	100G115 T4181V003	420	TFE21R9115C
				100	162	144			TFE21RA115C
				110	157	139			TFE21RB115C
				120	147	129			TFE21RC115C
	1480	1152	1165	90	167	149	100G115 T4181V003	550	TFE21R9115M
				100	162	144			TFE21RA115M
				110	157	139			TFE21RB115M
				120	147	129			TFE21RC115M
	1570	1202	1215	90	167	149	100G115 T4181V003	630	TFE21R9115L
				100	162	144			TFE21RA115L
				110	157	139			TFE21RB115L
				120	147	129			TFE21RC115L

Sospensioni meccaniche agricole _ Agricultural mechanical suspensions

Balestra - Spring 100 mm

TRIDEM

STANDARD

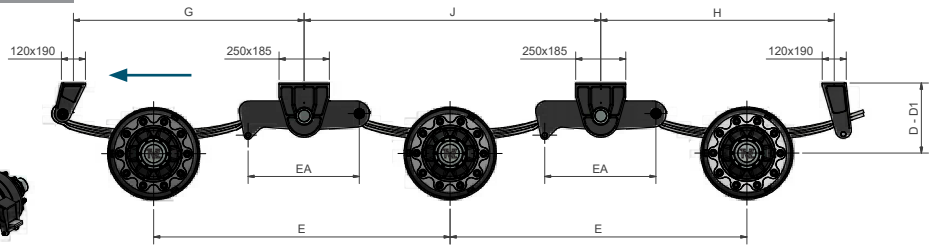
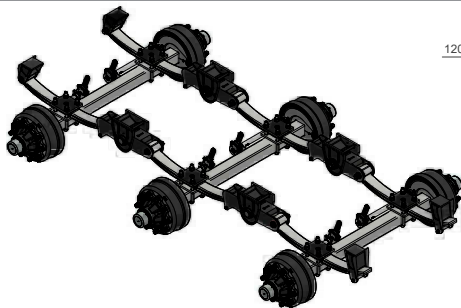

C (kg) PORTATA Capacity	E (mm)	G (mm)	J (mm)	H (mm)	ASSALE Axle	D (mm)	D1 (mm)	BALESTRA Spring	EA (mm)	CODICE Code
31000	1350	1087	1350	1100	90	341	323	100G115 T4181V003	420	KFE31N9115C
					100	346	328			KFE31NA115C
					110	351	333			KFE31NB115C
					120	361	343			KFE31NC115C
	1480	1152	1480	1165	90	341	323	100G115 T4181V003	550	KFE31N9115M
					100	346	328			KFE31NA115M
					110	351	333			KFE31NB115M
					120	361	343			KFE31NC115M
	1570	1202	1570	1215	90	341	323	100G115 T4181V003	630	KFE31N9115L
					100	346	328			KFE31NA115L
					110	351	333			KFE31NB115L
					120	361	343			KFE31NC115L

RIBASSATO / UNDERSLUNG

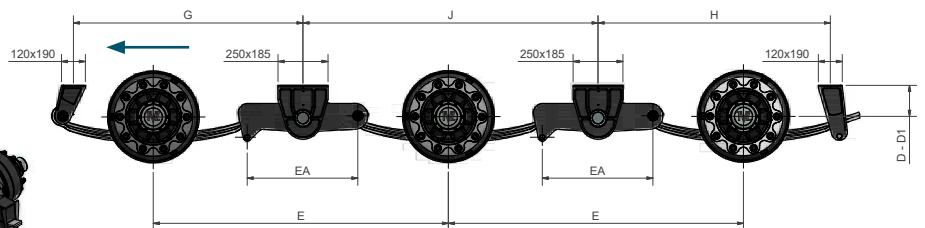
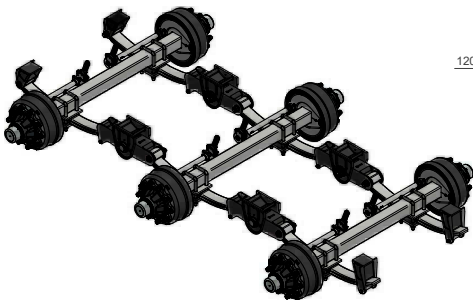

C (kg) PORTATA Capacity	E (mm)	G (mm)	J (mm)	H (mm)	ASSALE Axle	D (mm)	D1 (mm)	BALESTRA Spring	EA (mm)	CODICE Code
31000	1350	1087	1350	1100	90	167	149	100G115 T4181V003	420	KFE31R9115C
					100	162	144			KFE31RA115C
					110	157	139			KFE31RB115C
					120	147	129			KFE31RC115C
	1480	1152	1480	1165	90	167	149	100G115 T4181V003	550	KFE31R9115M
					100	162	144			KFE31RA115M
					110	157	139			KFE31RB115M
					120	147	129			KFE31RC115M
	1570	1202	1570	1215	90	167	149	100G115 T4181V003	630	KFE31R9115L
					100	162	144			KFE31RA115L
					110	157	139			KFE31RB115L
					120	147	129			KFE31RC115L



Sospensioni meccaniche industriali _ Industrial mechanical suspensions

MONO

Balestra - Spring 76 mm

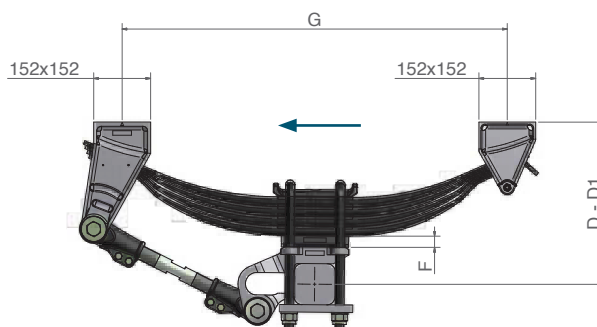
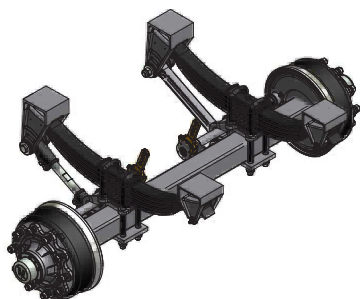

C (kg) PORTATA Capacity	G (mm)	ASSALE Axle	F (mm)	D (mm)	D1 (mm)	BALESTRA Spring	CODICE - Code
8000	825	90	0	315	280	3x23x1000	ST1E5N0932
			30	345	310		ST1E5N0935
			60	375	340		ST1E5N0938
		100	0	315	280	3x23x1000	ST1E5N1032
			30	345	310		ST1E5N1035
			60	375	340		ST1E5N1038
		120	0	315	280	3x23x1000	ST1E5N1232
			30	345	310		ST1E5N1235
			60	375	340		ST1E5N1238
		Ø127	0	315	280	3x23x1000	ST1E5NT132
			30	345	310		ST1E5NT135
			60	375	340		ST1E5NT138
10000	990	90	0	365	315	3x25x1150	ST1E7N0937
			30	395	345		ST1E7N0940
			60	425	375		ST1E7N0943
		100	0	365	315	3x25x1150	ST1E7N1037
			30	395	345		ST1E7N1040
			60	425	375		ST1E7N1043
		110	0	365	315	3x25x1150	ST1E7N1137
			30	395	345		ST1E7N1140
			60	425	375		ST1E7N1143
		120	0	365	315	3x25x1150	ST1E7N1237
			30	395	345		ST1E7N1240
			60	425	375		ST1E7N1243
		130	0	365	315	3x25x1150	ST1E7N1337
			30	395	345		ST1E7N1340
			60	425	375		ST1E7N1343
		Ø127	0	365	315	3x25x1150	ST1E7NT137
			30	395	345		ST1E7NT140
			60	425	375		ST1E7NT143

C	PORTATA DI 2 BALESTRE	CAPACITY OF 2 SPRINGS
D	ALTEZZA A VUOTO	HEIGHT WHEN EMPTY
D1	ALTEZZA SOTTO CARICO	HEIGHT WHEN LOADED

Sospensioni meccaniche industriali _ Industrial mechanical suspensions

Balestra - Spring 76 mm

MONO

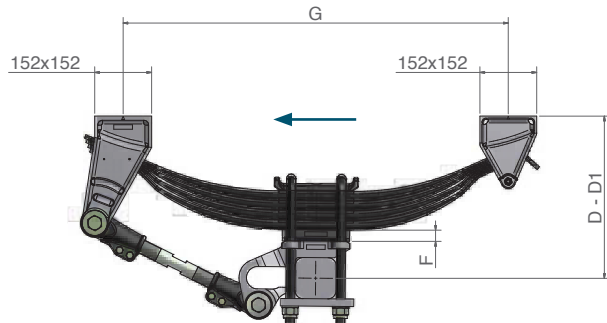
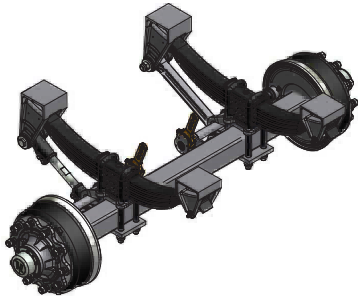

C (kg) PORTATA Capacity	G (mm)	ASSALE Axle	F (mm)	D (mm)	D1 (mm)	BALESTRA Spring	CODICE - Code		
10000	1030	90	0	370	323	3X25X1197	ST1E1N0938		
			30	400	353		ST1E1N0941		
			60	430	383		ST1E1N0944		
		100	0	370	323	3X25X1197	ST1E1N1038		
			30	400	353		ST1E1N1041		
			60	430	383		ST1E1N1044		
		110	0	370	323	3X25X1197	ST1E1N1138		
			30	400	353		ST1E1N1141		
			60	430	383		ST1E1N1144		
		120	0	370	323	3X25X1197	ST1E1N1238		
			30	400	353		ST1E1N1241		
			60	430	383		ST1E1N1244		
		130	0	370	323	3X25X1197	ST1E1N1338		
			30	400	353		ST1E1N1341		
			60	430	383		ST1E1N1344		
		Ø127	0	370	323	3X25X1197	ST1E1NT138		
			30	400	353		ST1E1NT141		
			60	430	383		ST1E1NT144		
		12000	1030	100	0	400	340	4x25x1197	ST1E4N1040
					30	430	370		ST1E4N1043
					60	460	400		ST1E4N1046
				110	0	400	340	4x25x1197	ST1E4N1140
					30	430	370		ST1E4N1143
					60	460	400		ST1E4N1146
120	0			400	340	4x25x1197	ST1E4N1240		
	30			430	370		ST1E4N1243		
	60			460	400		ST1E4N1246		
130	0			400	340	4x25x1197	ST1E4N1340		
	30			430	370		ST1E4N1343		
	60			460	400		ST1E4N1346		
Ø127	0			400	340	4x25x1197	ST1E4NT140		
	30			430	370		ST1E4NT143		
	60			460	400		ST1E4NT146		

C	PORTATA DI 2 BALESTRE	CAPACITY OF 2 SPRINGS
D	ALTEZZA A VUOTO	HEIGHT WHEN EMPTY
D1	ALTEZZA SOTTO CARICO	HEIGHT WHEN LOADED

TANDEM

Balestra - Spring 76 mm

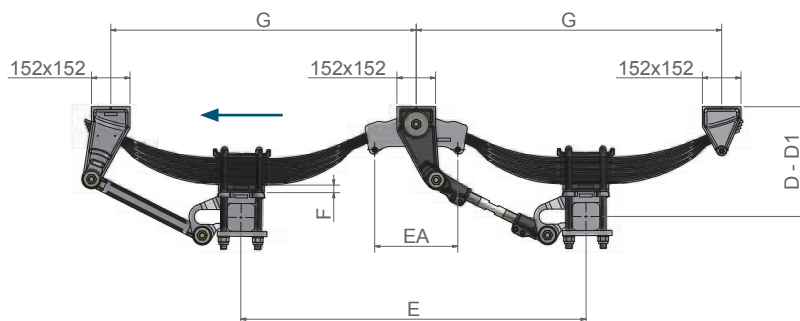
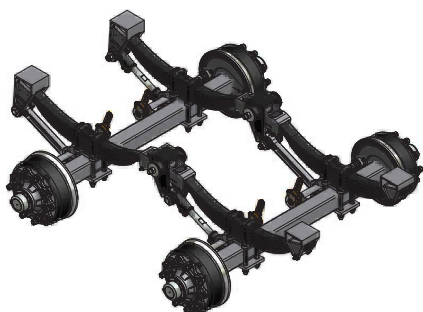

C PORTATA Capacity (kg)	E (mm)	G (mm)	ASSALE Axle	F (mm)	D (mm)	D1 (mm)	BALESTRA DAVANTI + DIETRO Spring front+rear	EA (mm)	CODICE - Code	
16000	1145	990	90	0	315	280	3x23x1000	336	ST2E5N0932	
				30	345	310			ST2E5N0935	
				60	375	340			ST2E5N0938	
		990	100	100	0	315	280	3x23x1000	336	ST2E5N1032
					30	345	310			ST2E5N1035
					60	375	340			ST2E5N1038
		990	120	120	0	315	280	3x23x1000	336	ST2E5N1232
					30	345	310			ST2E5N1235
					60	375	340			ST2E5N1238
		990	Ø127	Ø127	0	315	280	3x23x1000	336	ST2E5NT132
					30	345	310			ST2E5NT135
					60	375	340			ST2E5NT138
	1200	1045	90	90	0	315	280	3x23x1000	400	ST2E6N0932
					30	345	310			ST2E6N0935
					60	375	340			ST2E6N0938
		1045	100	100	0	315	280	3x23x1000	400	ST2E6N1032
					30	345	310			ST2E6N1035
					60	375	340			ST2E6N1038
		1045	120	120	0	315	280	3x23x1000	400	ST2E6N1232
					30	345	310			ST2E6N1235
					60	375	340			ST2E6N1238
		1045	Ø127	Ø127	0	315	280	3x23x1000	400	ST2E6NT132
					30	345	310			ST2E6NT135
					60	375	340			ST2E6NT138
	1310	1075	90	90	0	315	280	3x23x1000	490	ST2E7N0932
					30	345	310			ST2E7N0935
					60	375	340			ST2E7N0938
		1075	100	100	0	315	280	3x23x1000	490	ST2E7N1032
					30	345	310			ST2E7N1035
					60	375	340			ST2E7N1038
		1075	120	120	0	315	280	3x23x1000	490	ST2E7N1232
					30	345	310			ST2E7N1235
					60	375	340			ST2E7N1238
		1075	Ø127	Ø127	0	315	280	3x23x1000	490	ST2E7NT132
					30	345	310			ST2E7NT135
					60	375	340			ST2E7NT138
20000	1310	1155	90	0	365	315	3x25x1150	336	ST2E7N0937	
				30	395	345			ST2E7N0940	
				60	425	375			ST2E7N0943	
		1155	100	100	0	365	315	3x25x1150	336	ST2E7N1037
					30	395	345			ST2E7N1040
					60	425	375			ST2E7N1043
		1155	110	110	0	365	315	3x25x1150	336	ST2E7N1137
					30	395	345			ST2E7N1140
					60	425	375			ST2E7N1143
		1155	120	120	0	365	315	3x25x1150	336	ST2E7N1237
					30	395	345			ST2E7N1240
					60	425	375			ST2E7N1243
		1155	130	130	0	365	315	3x25x1150	336	ST2E7N1337
					30	395	345			ST2E7N1340
					60	425	375			ST2E7N1343
		1155	Ø127	Ø127	0	365	315	3x25x1150	336	ST2E7NT137
					30	395	345			ST2E7NT140
					60	425	375			ST2E7NT143

Sospensioni meccaniche industriali _ Industrial mechanical suspensions

Balestra - Spring 76 mm

TANDEM

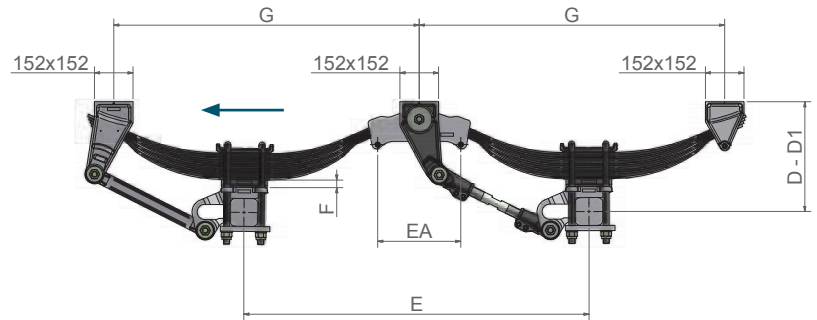
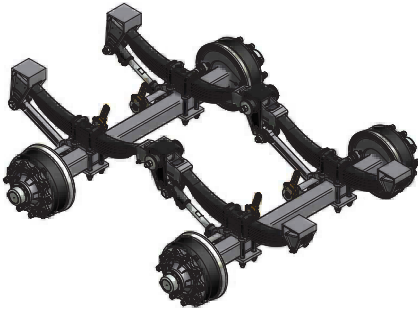

C PORTATA Capacity (kg)	E (mm)	G (mm)	ASSALE Axle	F (mm)	D (mm)	D1 (mm)	BALESTRA DAVANTI + DIETRO Spring front+rear	EA (mm)	CODICE - Code	
20000	1360	1205	90	0	370	323	3x25x1197	336	ST2E1N0938	
				30	400	353			ST2E1N0941	
				60	430	383			ST2E1N0944	
		1205	100	100	0	370	323	3x25x1197	336	ST2E1N1038
					30	400	353			ST2E1N1041
					60	430	383			ST2E1N1044
		1205	110	110	0	370	323	3x25x1197	336	ST2E1N1138
					30	400	353			ST2E1N1141
					60	430	383			ST2E1N1144
		1205	120	120	0	370	323	3x25x1197	336	ST2E1N1238
					30	400	353			ST2E1N1241
					60	430	383			ST2E1N1244
		1205	130	130	0	370	323	3x25x1197	336	ST2E1N1338
					30	400	353			ST2E1N1341
					60	430	383			ST2E1N1344
		1205	Ø127	Ø127	0	370	323	3x25x1197	336	ST2E1NT138
					30	400	353			ST2E1NT141
					60	430	383			ST2E1NT144
	1400 (1410) ¹	1225	90	90	0	370	323	3x25x1197	400	ST2E8N0938
					30	400	353			ST2E8N0941
					60	430	383			ST2E8N0944
		1225	100	100	0	370	323	3x25x1197	400	ST2E8N1038
					30	400	353			ST2E8N1041
					60	430	383			ST2E8N1044
		1225	110	110	0	370	323	3x25x1197	400	ST2E8N1138
					30	400	353			ST2E8N1141
					60	430	383			ST2E8N1144
		1225	120	120	0	370	323	3x25x1197	400	ST2E8N1238
					30	400	353			ST2E8N1241
					60	430	383			ST2E8N1244
		1225	130	130	0	370	323	3x25x1197	400	ST2E8N1338
					30	400	353			ST2E8N1341
					60	430	383			ST2E8N1344
		1225	Ø127	Ø127	0	370	323	3x25x1197	400	ST2E8NT138
					30	400	353			ST2E8NT141
					60	430	383			ST2E8NT144
1525 (1480) ¹	1285	90	90	0	370	323	3x25x1197	490	ST2E2N0938	
				30	400	353			ST2E2N0941	
				60	430	383			ST2E2N0944	
	1285	100	100	0	370	323	3x25x1197	490	ST2E2N1038	
				30	400	353			ST2E2N1041	
				60	430	383			ST2E2N1044	
	1285	110	110	0	370	323	3x25x1197	490	ST2E2N1138	
				30	400	353			ST2E2N1141	
				60	430	383			ST2E2N1144	
	1285	120	120	0	370	323	3x25x1197	490	ST2E2N1238	
				30	400	353			ST2E2N1241	
				60	430	383			ST2E2N1244	
	1285	130	130	0	370	323	3x25x1197	490	ST2E2N1338	
				30	400	353			ST2E2N1341	
				60	430	383			ST2E2N1344	
	1285	Ø127	Ø127	0	370	323	3x25x1197	490	ST2E2NT138	
				30	400	353			ST2E2NT141	
				60	430	383			ST2E2NT144	

¹Valori di passo tra parentesi ottenibili modificando le lunghezze dei tiranti e/o le quote delle posizioni G, prego contattare l'ufficio tecnico.

¹Wheelbase values in brackets obtainable by modifying the lengths of the tie rods and / or the dimension of the positions G, please contact the technical office.

TANDEM

Balestra - Spring 76 mm

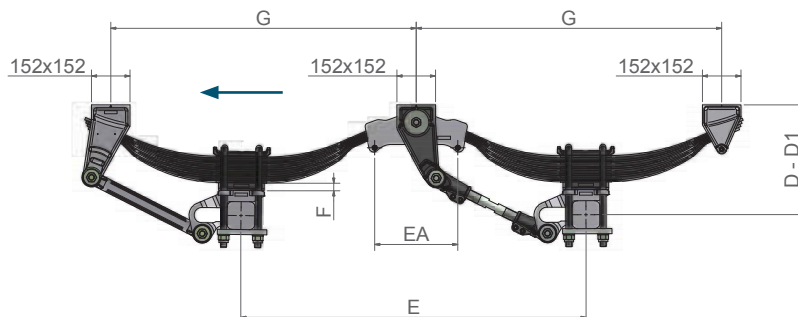
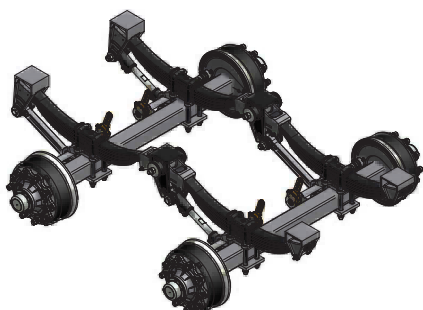

C PORTATA Capacity (kg)	E (mm)	G (mm)	ASSALE Axle	F (mm)	D (mm)	D1 (mm)	BALESTRA DAVANTI + DIETRO Spring front+rear	EA (mm)	CODICE - Code		
24000	1360	1205	100	0	400	340	4x25x1197	336	ST2E4N1040		
				30	430	370			ST2E4N1043		
				60	460	400			ST2E4N1046		
		1205	110	110	0	400	340	4x25x1197	336	ST2E4N1140	
					30	430	370			ST2E4N1143	
					60	460	400			ST2E4N1146	
		1205	120	120	0	400	340	4x25x1197	336	ST2E4N1240	
					30	430	370			ST2E4N1243	
					60	460	400			ST2E4N1246	
		1205	130	130	0	400	340	4x25x1197	336	ST2E4N1340	
					30	430	370			ST2E4N1343	
					60	460	400			ST2E4N1346	
		1205	Ø127	Ø127	0	400	340	4x25x1197	336	ST2E4NT140	
					30	430	370			ST2E4NT143	
					60	460	400			ST2E4NT146	
		1400 (1410) ¹	1225	100	100	0	400	340	4x25x1197	400	ST2E9N1040
						30	430	370			ST2E9N1043
						60	460	400			ST2E9N1046
			1225	110	110	0	400	340	4x25x1197	400	ST2E9N1140
						30	430	370			ST2E9N1143
						60	460	400			ST2E9N1146
			1225	120	120	0	400	340	4x25x1197	400	ST2E9N1240
						30	430	370			ST2E9N1243
						60	460	400			ST2E9N1246
	1225		130	130	0	400	340	4x25x1197	400	ST2E9N1340	
					30	430	370			ST2E9N1343	
					60	460	400			ST2E9N1346	
	1225		Ø127	Ø127	0	400	340	4x25x1197	400	ST2E9NT140	
					30	430	370			ST2E9NT143	
					60	460	400			ST2E9NT146	
	1525 (1480) ¹		1285	100	100	0	400	340	4x25x1197	490	ST2E5N1040
						30	430	370			ST2E5N1043
						60	460	400			ST2E5N1046
			1285	110	110	0	400	340	4x25x1197	490	ST2E5N1140
						30	430	370			ST2E5N1143
						60	460	400			ST2E5N1146
			1285	120	120	0	400	340	4x25x1197	490	ST2E5N1240
						30	430	370			ST2E5N1243
						60	460	400			ST2E5N1246
		1285	130	130	0	400	340	4x25x1197	490	ST2E5N1340	
					30	430	370			ST2E5N1343	
					60	460	400			ST2E5N1346	
		1285	Ø127	Ø127	0	400	340	4x25x1197	490	ST2E5NT140	
					30	430	370			ST2E5NT143	
					60	460	400			ST2E5NT146	

¹Valori di passo tra parentesi ottenibili modificando le lunghezze dei tiranti e/o le quote delle posizioni G, prego contattare l'ufficio tecnico.

¹Wheelbase values in brackets obtainable by modifying the lengths of the tie rods and /or the dimension of the positions G, please contact the technical office.

C	PORTATA DI 4 BALESTRE	CAPACITY OF 4 SPRINGS
E	PASSO	WHEEL BASE
D	ALTEZZA A VUOTO	HEIGHT WHEN EMPTY
D1	ALTEZZA SOTTO CARICO	HEIGHT WHEN LOADED

Balestra - Spring 76 mm

TRIDEM

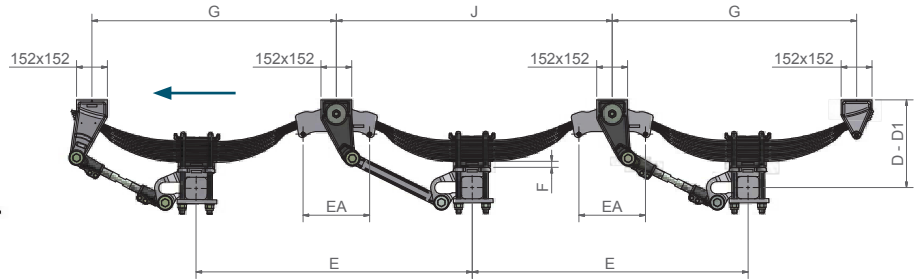

C (kg) PORTATA Capacity	E (mm)	G (mm)	J (mm)	ASSALE Axle	F (mm)	D (mm)	D1 (mm)	BALESTRA DAVANTI + DIETRO Spring front+rear	BALESTRA IN MEZZO Spring in half	EA (mm)	CODICE - Code	
24000	1145	990	1145	90	0	315	280	3x23x1000	3x23x972	336	ST3E5N0932	
					30	345	310				ST3E5N0935	
					60	375	340				ST3E5N0938	
		990	1145	100	0	315	280	3x23x1000	3x23x972	336	ST3E5N1032	
					30	345	310				ST3E5N1035	
					60	375	340				ST3E5N1038	
		990	1145	120	0	315	280	3x23x1000	3x23x972	336	ST3E5N1232	
					30	345	310				ST3E5N1235	
					60	375	340				ST3E5N1238	
		990	1145	Ø127	0	315	280	3x23x1000	3x23x972	336	ST3E5NT132	
					30	345	310				ST3E5NT135	
					60	375	340				ST3E5NT138	
	1200	1045	1200	90	0	315	280	3x23x1000	3x23x972	400	ST3E6N0932	
					30	345	310				ST3E6N0935	
					60	375	340				ST3E6N0938	
			1045	1200	100	0	315	280	3x23x1000	3x23x972	400	ST3E6N1032
						30	345	310				ST3E6N1035
						60	375	340				ST3E6N1038
		1045	1200	120	0	315	280	3x23x1000	3x23x972	400	ST3E6N1232	
					30	345	310				ST3E6N1235	
					60	375	340				ST3E6N1238	
		1045	1200	Ø127	0	315	280	3x23x1000	3x23x972	400	ST3E6NT132	
					30	345	310				ST3E6NT135	
					60	375	340				ST3E6NT138	
1310	1075	1310	90	0	315	280	3x23x1000	3x23x972	490	ST3E7N0932		
				30	345	310				ST3E7N0935		
				60	375	340				ST3E7N0938		
		1075	1310	100	0	315	280	3x23x1000	3x23x972	490	ST3E7N1032	
					30	345	310				ST3E7N1035	
					60	375	340				ST3E7N1038	
	1075	1310	120	0	315	280	3x23x1000	3x23x972	490	ST3E7N1232		
				30	345	310				ST3E7N1235		
				60	375	340				ST3E7N1238		
	1075	1310	Ø127	0	315	280	3x23x1000	3x23x972	490	ST3E7NT132		
				30	345	310				ST3E7NT135		
				60	375	340				ST3E7NT138		

C	PORTATA DI 6 BALESTRE	CAPACITY OF 6 SPRINGS
E	PASSO	WHEEL BASE
D	ALTEZZA A VUOTO	HEIGHT WHEN EMPTY
D1	ALTEZZA SOTTO CARICO	HEIGHT WHEN LOADED

TRIDEM

Balestra - Spring 76 mm

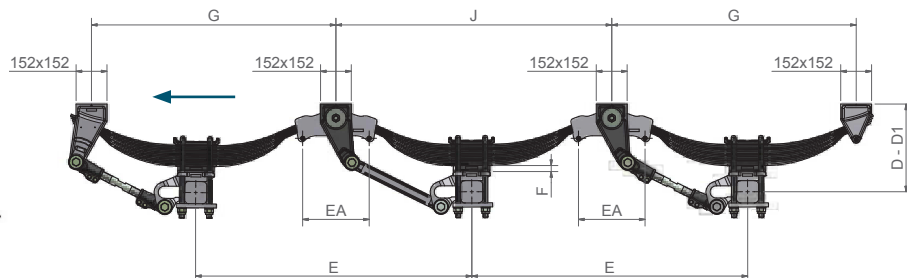

C (kg) PORTATA Capacity	E (mm)	G (mm)	J (mm)	ASSALE Axle	F (mm)	D (mm)	D1 (mm)	BALESTRA DAVANTI + DIETRO Spring front+rear	BALESTRA IN MEZZO Spring in half	EA (mm)	CODICE - Code			
30000	1360	1205	1360	100	0	370	323	3x25x1197	3x25x1175	336	ST3E8N1038			
					30	400	353				ST3E8N1041			
					60	430	383				ST3E8N1044			
		1205	1360	110	110	110	0	370	323	3x25x1197	3x25x1175	336	ST3E8N1138	
							30	400	353				ST3E8N1141	
							60	430	383				ST3E8N1144	
		1205	1360	120	1360	120	0	370	323	3x25x1197	3x25x1175	336	ST3E8N1238	
							30	400	353				ST3E8N1241	
							60	430	383				ST3E8N1244	
		1205	1360	130	1360	130	0	370	323	3x25x1197	3x25x1175	336	ST3E8N1338	
							30	400	353				ST3E8N1341	
							60	430	383				ST3E8N1344	
		1205	1360	Ø127	1360	Ø127	0	370	323	3x25x1197	3x25x1175	336	ST3E8NT138	
							30	400	353				ST3E8NT141	
							60	430	383				ST3E8NT144	
		1400 (1410) ¹	1400	1225	1400	100	0	370	323	3x25x1197	3x25x1175	400	ST3E3N1038	
							30	400	353				ST3E3N1041	
							60	430	383				ST3E3N1044	
	1225			1400	110	1400	110	0	370	323	3x25x1197	3x25x1175	400	ST3E3N1138
								30	400	353				ST3E3N1141
								60	430	383				ST3E3N1144
	1225			1400	120	1400	120	0	370	323	3x25x1197	3x25x1175	400	ST3E3N1238
								30	400	353				ST3E3N1241
								60	430	383				ST3E3N1244
	1225			1400	130	1400	130	0	370	323	3x25x1197	3x25x1175	400	ST3E3N1338
								30	400	353				ST3E3N1341
								60	430	383				ST3E3N1344
	1225			1400	Ø127	1400	Ø127	0	370	323	3x25x1197	3x25x1175	400	ST3E3NT138
								30	400	353				ST3E3NT141
								60	430	383				ST3E3NT144
	1525 (1480) ¹			1525	1285	1525	100	0	370	323	3x25x1197	3x25x1175	490	ST3E9N1038
								30	400	353				ST3E9N1041
								60	430	383				ST3E9N1044
		1285	1525		110	1525	110	0	370	323	3x25x1197	3x25x1175	490	ST3E9N1138
								30	400	353				ST3E9N1141
								60	430	383				ST3E9N1144
1285		1525	120		1525	120	0	370	323	3x25x1197	3x25x1175	490	ST3E9N1238	
							30	400	353				ST3E9N1241	
							60	430	383				ST3E9N1244	
1285		1525	130		1525	130	0	370	323	3x25x1197	3x25x1175	490	ST3E9N1338	
							30	400	353				ST3E9N1341	
							60	430	383				ST3E9N1344	
1285		1525	Ø127		1525	Ø127	0	370	323	3x25x1197	3x25x1175	490	ST3E9NT138	
							30	400	353				ST3E9NT141	
							60	430	383				ST3E9NT144	

¹Valori di passo tra parentesi ottenibili modificando le lunghezze dei tiranti e/o le quote delle posizioni G/J, prego contattare l'ufficio tecnico.

¹Wheelbase values in brackets obtainable by modifying the lengths of the tie rods and / or the dimension of the positions G/J, please contact the technical office.

Sospensioni meccaniche industriali _ Industrial mechanical suspensions

Balestra - Spring 76 mm

TRIDEM

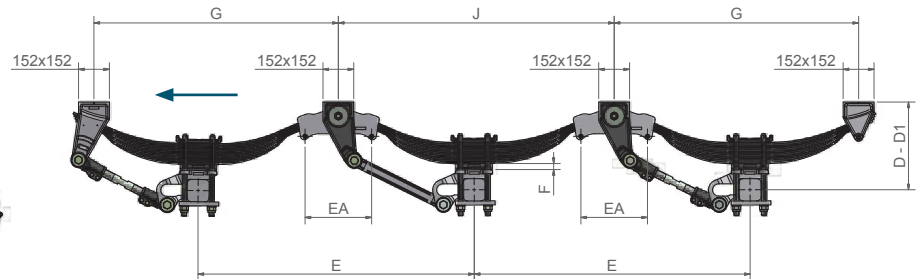

C (kg) PORTATA Capacity	E (mm)	G (mm)	J (mm)	ASSALE Axle	F (mm)	D (mm)	D1 (mm)	BALESTRA DAVANTI + DIETRO Spring front+rear	BALESTRA IN MEZZO Spring in half	EA (mm)	CODICE - Code		
36000	1360	1205	1360	100	0	400	340	4x25x1197	4x25x1175	336	ST3EAN1040		
					30	430	370				ST3EAN1043		
					60	460	400				ST3EAN1046		
		1205	1360	110	1360	110	0	400	340	4x25x1197	4x25x1175	336	ST3EAN1140
							30	430	370				ST3EAN1143
							60	460	400				ST3EAN1146
		1205	1360	120	1360	120	0	400	340	4x25x1197	4x25x1175	336	ST3EAN1240
							30	430	370				ST3EAN1243
							60	460	400				ST3EAN1246
		1205	1360	130	1360	130	0	400	340	4x25x1197	4x25x1175	336	ST3EAN1340
							30	430	370				ST3EAN1343
							60	460	400				ST3EAN1346
	1205	1360	Ø127	1360	Ø127	0	400	340	4x25x1197	4x25x1175	336	ST3EANT140	
						30	430	370				ST3EANT143	
						60	460	400				ST3EANT146	
	1400 (1410) ¹	1225	1400	1400	100	0	400	340	4x25x1197	4x25x1175	400	ST3E4N1040	
						30	430	370				ST3E4N1043	
						60	460	400				ST3E4N1046	
		1225	1400	1400	1400	110	0	400	340	4x25x1197	4x25x1175	400	ST3E4N1140
							30	430	370				ST3E4N1143
							60	460	400				ST3E4N1146
		1225	1400	1400	1400	120	0	400	340	4x25x1197	4x25x1175	400	ST3E4N1240
							30	430	370				ST3E4N1243
							60	460	400				ST3E4N1246
		1225	1400	1400	1400	130	0	400	340	4x25x1197	4x25x1175	400	ST3E4N1340
							30	430	370				ST3E4N1343
							60	460	400				ST3E4N1346
	1225	1400	1400	1400	Ø127	0	400	340	4x25x1197	4x25x1175	400	ST3E4NT140	
						30	430	370				ST3E4NT143	
						60	460	400				ST3E4NT146	
	1525 (1480) ¹	1285	1525	1525	100	0	400	340	4x25x1197	4x25x1175	490	ST3EBN1040	
						30	430	370				ST3EBN1043	
						60	460	400				ST3EBN1046	
		1285	1525	1525	1525	110	0	400	340	4x25x1197	4x25x1175	490	ST3EBN1140
							30	430	370				ST3EBN1143
							60	460	400				ST3EBN1146
1285		1525	1525	1525	120	0	400	340	4x25x1197	4x25x1175	490	ST3EBN1240	
						30	430	370				ST3EBN1243	
						60	460	400				ST3EBN1246	
1285		1525	1525	1525	130	0	400	340	4x25x1197	4x25x1175	490	ST3EBN1340	
						30	430	370				ST3EBN1343	
						60	460	400				ST3EBN1346	
1285	1525	1525	1525	Ø127	0	400	340	4x25x1197	4x25x1175	490	ST3EBNT140		
					30	430	370				ST3EBNT143		
					60	460	400				ST3EBNT146		

¹Valori di passo tra parentesi ottenibili modificando le lunghezze dei tiranti e/o le quote delle posizioni G/J, prego contattare l'ufficio tecnico.

¹Wheelbase values in brackets obtainable by modifying the lengths of the tie rods and / or the dimension of the positions G/J, please contact the technical office.

QUADREM

Balestra - Spring 76 mm

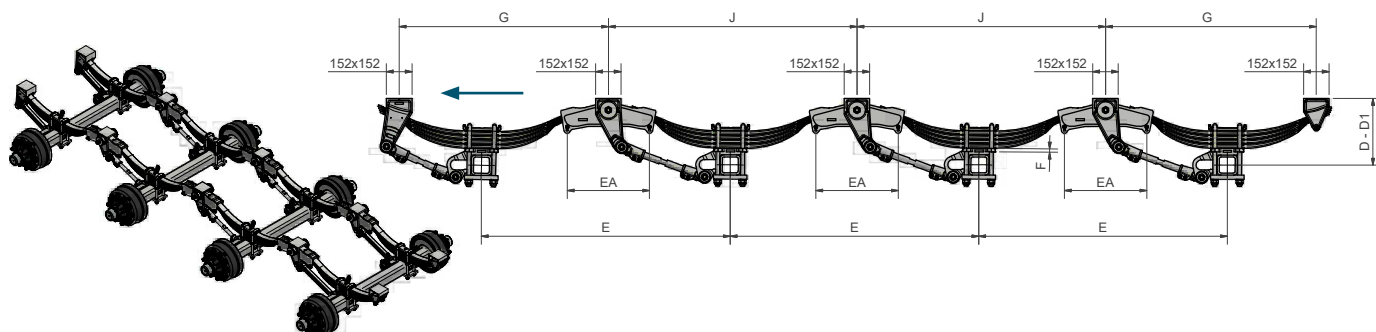

C (kg) PORTATA Capacity	E (mm)	G (mm)	J (mm)	ASSALE Axle	F (mm)	D (mm)	D1 (mm)	BALESTRA DAVANTI + DIETRO Spring front+rear	BALESTRE IN MEZZO Springs in half	EA (mm)	CODICE - Code				
40000	1360	1205	1360	100	0	370	323	3x25x1197	3x25x1175	336	ST4E8N1038				
					30	400	353				ST4E8N1041				
					60	430	383				ST4E8N1044				
				0	370	323	ST4E8N1138								
				30	400	353	ST4E8N1141								
				60	430	383	ST4E8N1144								
		110	1205	1360	110	0	370	323	3x25x1197	3x25x1175	336	ST4E8N1238			
						30	400	353				ST4E8N1241			
						60	430	383				ST4E8N1244			
		120	1205	1360	120	0	370	323	3x25x1197	3x25x1175	336	ST4E8N1338			
						30	400	353				ST4E8N1341			
						60	430	383				ST4E8N1344			
		130	1205	1360	130	0	370	323	3x25x1197	3x25x1175	336	ST4E8N138			
						30	400	353				ST4E8N141			
						60	430	383				ST4E8N144			
		Ø127	1205	1360	Ø127	0	370	323	3x25x1197	3x25x1175	336	ST4E8NT138			
						30	400	353				ST4E8NT141			
						60	430	383				ST4E8NT144			
						0	370	323				3x25x1197	3x25x1175	400	ST4E3N1038
						30	400	353							ST4E3N1041
						60	430	383							ST4E3N1044
		100	1225	1400	100	0	370	323	3x25x1197	3x25x1175	400	ST4E3N1138			
						30	400	353				ST4E3N1141			
						60	430	383				ST4E3N1144			
	0					370	323	3x25x1197				3x25x1175	400	ST4E3N1238	
	30					400	353							ST4E3N1241	
	60					430	383							ST4E3N1244	
	110	1225	1400	110	0	370	323	3x25x1197	3x25x1175	400	ST4E3N1338				
					30	400	353				ST4E3N1341				
					60	430	383				ST4E3N1344				
					0	370	323				3x25x1197	3x25x1175	400	ST4E3NT138	
					30	400	353							ST4E3NT141	
					60	430	383							ST4E3NT144	
	120	1225	1400	120	0	370	323	3x25x1197	3x25x1175	400	ST4E3NT138				
					30	400	353				ST4E3NT141				
					60	430	383				ST4E3NT144				
					0	370	323				3x25x1197	3x25x1175	490	ST4E9N1038	
					30	400	353							ST4E9N1041	
					60	430	383							ST4E9N1044	
	110	1285	1525	110	0	370	323	3x25x1197	3x25x1175	490	ST4E9N1138				
					30	400	353				ST4E9N1141				
					60	430	383				ST4E9N1144				
					0	370	323				3x25x1197	3x25x1175	490	ST4E9N1238	
					30	400	353							ST4E9N1241	
					60	430	383							ST4E9N1244	
	120	1285	1525	120	0	370	323	3x25x1197	3x25x1175	490	ST4E9N1338				
					30	400	353				ST4E9N1341				
					60	430	383				ST4E9N1344				
0					370	323	3x25x1197				3x25x1175	490	ST4E9NT138		
30					400	353							ST4E9NT141		
60					430	383							ST4E9NT144		
130	1285	1525	130	0	370	323	3x25x1197	3x25x1175	490	ST4E9NT138					
				30	400	353				ST4E9NT141					
				60	430	383				ST4E9NT144					
				0	370	323				3x25x1197	3x25x1175	490	ST4E9N1038		
				30	400	353							ST4E9N1041		
				60	430	383							ST4E9N1044		
Ø127	1285	1525	Ø127	0	370	323	3x25x1197	3x25x1175	490	ST4E9N1138					
				30	400	353				ST4E9N1141					
				60	430	383				ST4E9N1144					
				0	370	323				3x25x1197	3x25x1175	490	ST4E9N1238		
				30	400	353							ST4E9N1241		
				60	430	383							ST4E9N1244		
100	1285	1525	100	0	370	323	3x25x1197	3x25x1175	490	ST4E9N1338					
				30	400	353				ST4E9N1341					
				60	430	383				ST4E9N1344					
				0	370	323				3x25x1197	3x25x1175	490	ST4E9NT138		
				30	400	353							ST4E9NT141		
				60	430	383							ST4E9NT144		

¹Valori di passo tra parentesi ottenibili modificando le lunghezze dei tiranti e/o le quote delle posizioni G/J, prego contattare l'ufficio tecnico.

¹Wheelbase values in brackets obtainable by modifying the lengths of the tie rods and / or the dimension of the positions G/J, please contact the technical office.

Sospensioni meccaniche industriali _ Industrial mechanical suspensions

Balestra - Spring 76 mm

QUADREM

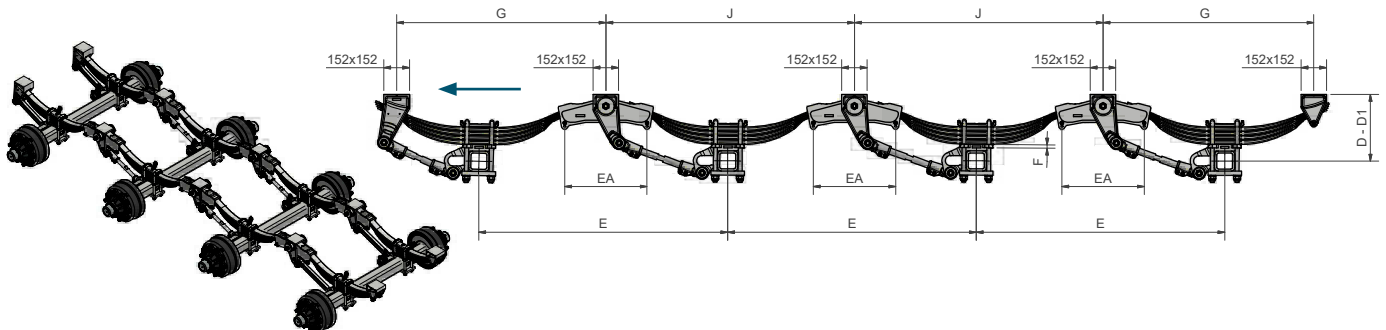

C (kg) PORTATA Capacity	E (mm)	G (mm)	J (mm)	ASSALE Axle	F (mm)	D (mm)	D1 (mm)	BALESTRA DAVANTI + DIETRO Spring front+rear	BALESTRE IN MEZZO Springs in half	EA (mm)	CODICE - Code		
48000	1360	1205	1360	100	0	400	340	4x25x1197	4x25x1175	336	ST4EAN1040		
					30	430	370				ST4EAN1043		
					60	460	400				ST4EAN1046		
		1205	1360	110	1360	110	0	400	340	4x25x1197	4x25x1175	336	ST4EAN1140
							30	430	370				ST4EAN1143
							60	460	400				ST4EAN1146
		1205	1360	120	1360	120	0	400	340	4x25x1197	4x25x1175	336	ST4EAN1240
							30	430	370				ST4EAN1243
							60	460	400				ST4EAN1246
		1205	1360	130	1360	130	0	400	340	4x25x1197	4x25x1175	336	ST4EAN1340
							30	430	370				ST4EAN1343
							60	460	400				ST4EAN1346
	1205	1360	Ø127	1360	Ø127	0	400	340	4x25x1197	4x25x1175	336	ST4EANT140	
						30	430	370				ST4EANT143	
						60	460	400				ST4EANT146	
	1400 (1410) ¹	1225	1400	1400	100	0	400	340	4x25x1197	4x25x1175	400	ST4E4N1040	
						30	430	370				ST4E4N1043	
						60	460	400				ST4E4N1046	
		1225	1400	1400	1400	110	0	400	340	4x25x1197	4x25x1175	400	ST4E4N1140
							30	430	370				ST4E4N1143
							60	460	400				ST4E4N1146
		1225	1400	1400	1400	120	0	400	340	4x25x1197	4x25x1175	400	ST4E4N1240
							30	430	370				ST4E4N1243
							60	460	400				ST4E4N1246
		1225	1400	1400	1400	130	0	400	340	4x25x1197	4x25x1175	400	ST4E4N1340
							30	430	370				ST4E4N1343
							60	460	400				ST4E4N1346
	1225	1400	1400	1400	Ø127	0	400	340	4x25x1197	4x25x1175	400	ST4E4NT140	
						30	430	370				ST4E4NT143	
						60	460	400				ST4E4NT146	
	1525 (1480) ¹	1285	1525	1525	100	0	400	340	4x25x1197	4x25x1175	490	ST4EBN1040	
						30	430	370				ST4EBN1043	
						60	460	400				ST4EBN1046	
		1285	1525	1525	1525	110	0	400	340	4x25x1197	4x25x1175	490	ST4EBN1140
							30	430	370				ST4EBN1143
							60	460	400				ST4EBN1146
1285		1525	1525	1525	120	0	400	340	4x25x1197	4x25x1175	490	ST4EBN1240	
						30	430	370				ST4EBN1243	
						60	460	400				ST4EBN1246	
1285		1525	1525	1525	130	0	400	340	4x25x1197	4x25x1175	490	ST4EBN1340	
						30	430	370				ST4EBN1343	
						60	460	400				ST4EBN1346	
1285	1525	1525	1525	Ø127	0	400	340	4x25x1197	4x25x1175	490	ST4EBNT140		
					30	430	370				ST4EBNT143		
					60	460	400				ST4EBNT146		

¹Valori di passo tra parentesi ottenibili modificando le lunghezze dei tiranti e/o le quote delle posizioni G/J, prego contattare l'ufficio tecnico.

¹Wheelbase values in brackets obtainable by modifying the lengths of the tie rods and / or the dimension of the positions G/J, please contact the technical office.



Sospensioni meccaniche industriali _ Industrial mechanical suspensions

TANDEM

Balestra - Spring 76 mm

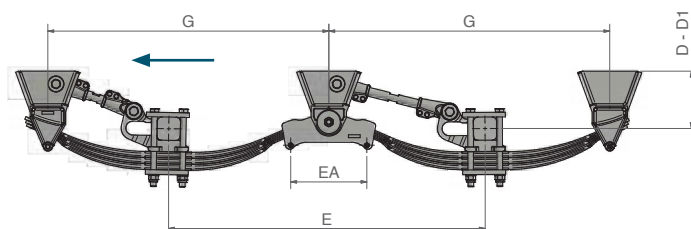
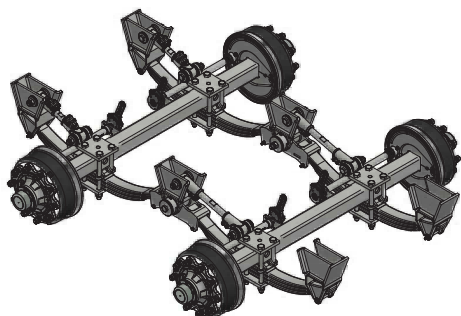

C (kg) PORTATA Capacity	E (mm)	G (mm)	ASSALE Axle	D (mm)	D1 (mm)	BALESTRA DAVANTI + DIETRO Spring front+rear	EA (mm)	CODICE - Code
16000	1145	1015	90	230	195	3x23x1000	336	ST2X7R0923
			100	230	195			ST2X7R1023
			120	230	195			ST2X7R1223
	1200	1040	90	230	195	3x23x1000	400	ST2X6R0923
			100	230	195			ST2X6R1023
			120	230	195			ST2X6R1223
	1310	1095	90	230	195	3x23x1000	490	ST2X5R0923
			100	230	195			ST2X5R1023
			120	230	195			ST2X5R1223
20000	1360	1210	100	290	243	3x25x1197	336	ST2X3R1029
			110	290	243			ST2X3R1129
			120	290	243			ST2X3R1229
	1400	1230	100	290	243	3x25x1197	400	ST2X1R1029
			110	290	243			ST2X1R1129
			120	290	243			ST2X1R1229
	1525	1280	100	290	243	3x25x1197	490	ST2X4R1029
			110	290	243			ST2X4R1129
			120	290	243			ST2X4R1229
24000	1360	1210	110	290	230	4x25x1197	336	ST2X8R1129
			120	290	230			ST2X8R1229
			130	290	230			ST2X8R1329
	1400	1230	110	290	230	4x25x1197	400	ST2X9R1129
			120	290	230			ST2X9R1229
			130	290	230			ST2X9R1329
	1525	1280	110	290	230	4x25x1197	490	ST2XAR1129
			120	290	230			ST2XAR1229
			130	290	230			ST2XAR1329

C	PORTATA DI 4 BALESTRE	CAPACITY OF 4 SPRINGS
E	PASSO	WHEEL BASE
D	ALTEZZA A VUOTO	HEIGHT WHEN EMPTY
D1	ALTEZZA SOTTO CARICO	HEIGHT WHEN LOADED

Sospensioni meccaniche industriali _ Industrial mechanical suspensions

Balestra - Spring 76 mm

TRIDEM

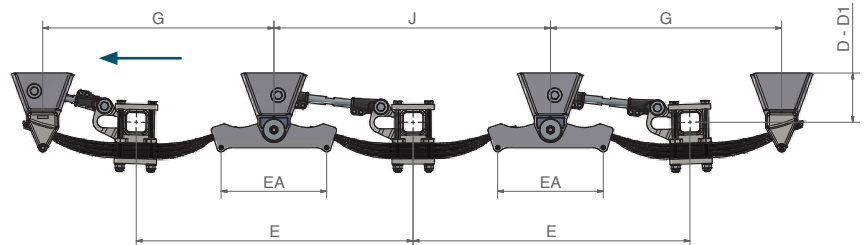
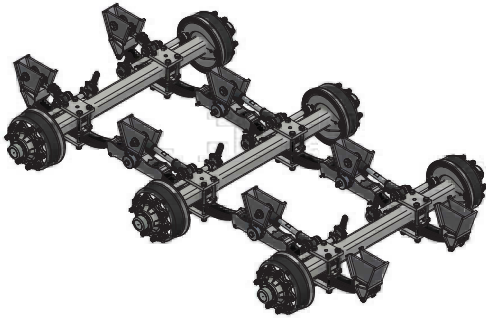

C (kg) PORTATA Capacity	E (mm)	G (mm)	J (mm)	ASSALE Axle	D (mm)	D1 (mm)	BALESTRA DAVANTI + DIETRO Spring front+rear	BALESTRA IN MEZZO Spring in half	EA (mm)	CODICE - Code
24000	1145	1015	1155	90	230	195	3x23x1000	3x23x972	336	ST3X7R0923
				100	230	195				ST3X7R1023
				120	230	195				ST3X7R1223
	1200	1040	1210	90	230	195	3x23x1000	3x23x972	400	ST3X6R0923
				100	230	195				ST3X6R1023
				120	230	195				ST3X6R1223
	1310	1095	1310	90	230	195	3x23x1000	3x23x972	490	ST3X5R0923
				100	230	195				ST3X5R1023
				120	230	195				ST3X5R1223
30000	1360	1210	1365	100	290	243	3x25x1197	3x25x1175	336	ST3X3R1029
				110	290	243				ST3X3R1129
				120	290	243				ST3X3R1229
	1400	1230	1400	100	290	243	3x25x1197	3x25x1175	400	ST3X1R1029
				110	290	243				ST3X1R1129
				120	290	243				ST3X1R1229
	1525	1280	1525	100	290	243	3x25x1197	3x25x1175	490	ST3X4R1029
				110	290	243				ST3X4R1129
				120	290	243				ST3X4R1229
36000	1360	1210	1365	110	290	230	4x25x1197	4x25x1175	336	ST3X8R1129
				120	290	230				ST3X8R1229
				130	290	230				ST3X8R1329
	1400	1230	1400	110	290	230	4x25x1197	4x25x1175	400	ST3X9R1129
				120	290	230				ST3X9R1229
				130	290	230				ST3X9R1329
	1525	1280	1525	110	290	230	4x25x1197	4x25x1175	490	ST3XAR1129
				120	290	230				ST3XAR1229
				130	290	230				ST3XAR1329

C	PORTATA DI 6 BALESTRE	CAPACITY OF 6 SPRINGS
E	PASSO	WHEEL BASE
D	ALTEZZA A VUOTO	HEIGHT WHEN EMPTY
D1	ALTEZZA SOTTO CARICO	HEIGHT WHEN LOADED

TANDEM

Balestra - Spring 100 mm

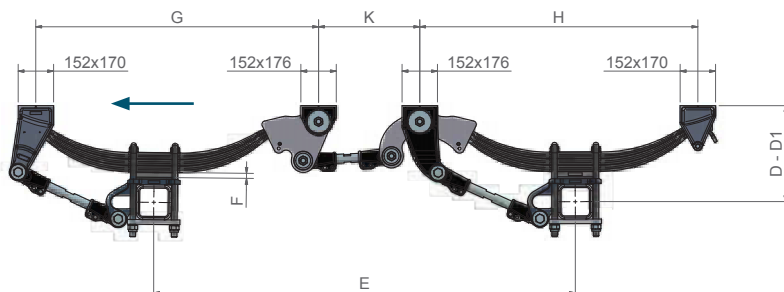
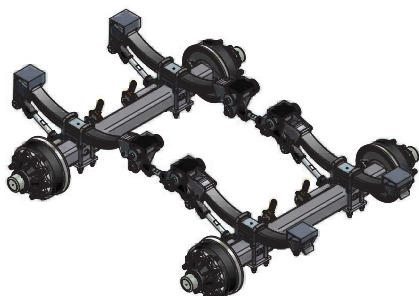

C (kg)	E (mm)	G (mm)	H (mm)	K (mm)	ASSALE Axle	F (mm)	D (mm)	D1 (mm)	BALESTRA DAVANTI + DIETRO Spring front+rear	CODICE - Code
24000	1810	1215	1195	435	110	0	385	363	3x27x1180	ST2F5N1141
						30	415	393		ST2F5N1144
						60	445	423		ST2F5N1147
		1215	1195	435	120	0	385	363	3x27x1180	ST2F5N1241
						30	415	393		ST2F5N1244
						60	445	423		ST2F5N1247
		1215	1195	435	130	0	385	363	3x27x1180	ST2F5N1341
						30	415	393		ST2F5N1344
						60	445	423		ST2F5N1347

C PORTATA DI 4 BALESTRE CAPACITY OF 4 SPRINGS

TRIDEM

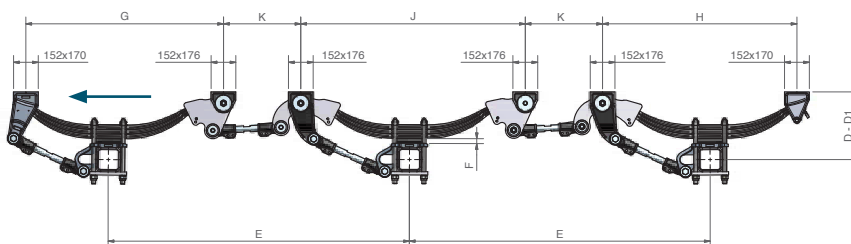
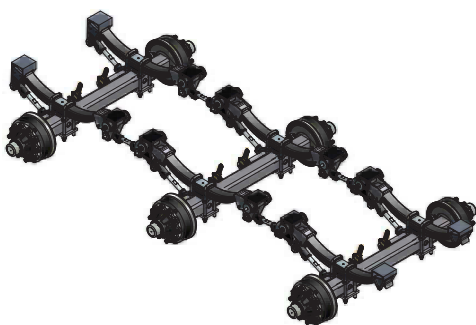

C (kg)	E (mm)	G (mm)	J (mm)	H (mm)	K (mm)	ASSALE Axle	F (mm)	D (mm)	D1 (mm)	BALESTRA DAVANTI + DIETRO Spring front+rear	BALESTRA IN MEZZO Spring in half	CODICE - Code
36000	1810	1215	1380	1195	435	110	0	385	363	3x27x1180	3x27x1180	ST3F5N1141
							30	415	393			ST3F5N1144
							60	445	423			ST3F5N1147
		1215	1380	1195	435	120	0	385	363	3x27x1180	3x27x1180	ST3F5N1241
							30	415	393			ST3F5N1244
							60	445	423			ST3F5N1247
		1215	1380	1195	435	130	0	385	363	3x27x1180	3x27x1180	ST3F5N1341
							30	415	393			ST3F5N1344
							60	445	423			ST3F5N1347

C PORTATA DI 6 BALESTRE CAPACITY OF 6 SPRINGS

E PASSO WHEEL BASE

D ALTEZZA A VUOTO HEIGHT WHEN EMPTY

D1 ALTEZZA SOTTO CARICO HEIGHT WHEN LOADED

Sospensioni meccaniche industriali _ Industrial mechanical suspensions

Balestra - Spring 100 mm

TANDEM

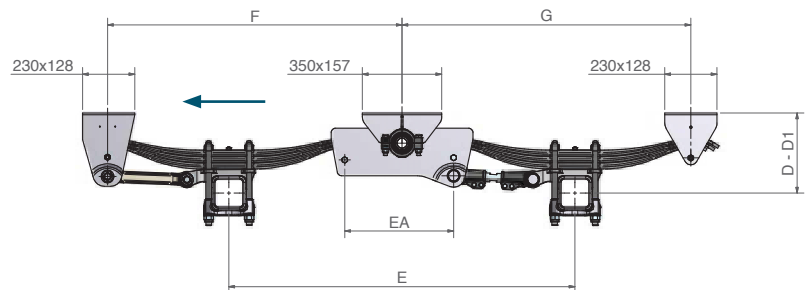
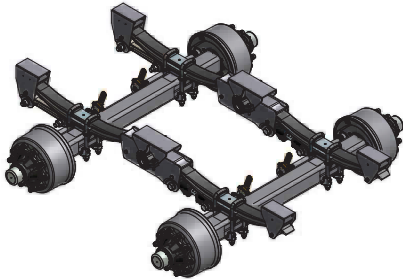

C (kg)	E (mm)	F (mm)	G (mm)	EA (mm)	ASSALE Axle	D (mm)	D1 (mm)	BALESTRA 1-2 Spring 1-2	CODE
24000	1410	1260	1220	355	130	330	307	2x30x1180	ST2C1N1331
	1525	1298	1273	480					ST2C2N1331
32000	1410	1260	1220	355	150	350	320	3x27x1190	ST2C1N1534
	1525	1298	1273	480					ST2C2N1534

C PORTATA DI 4 BALESTRE CAPACITY OF 4 SPRINGS

TRIDEM

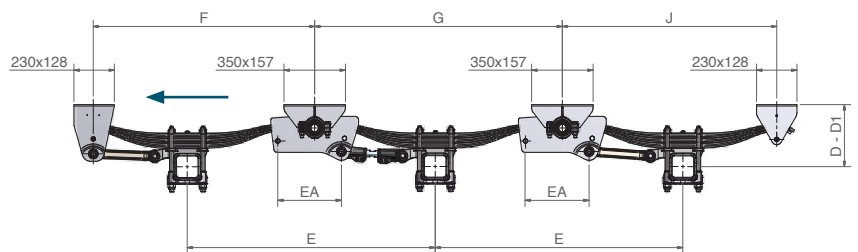

C (kg)	E (mm)	F (mm)	G (mm)	J (mm)	EA (mm)	ASSALE Axle	D (mm)	D1 (mm)	BALESTRA 1-2-3 Spring 1-2-3	CODE
36000	1410	1260	1410	1220	355	130	330	307	2X30X1180	ST3C1N1331
	1525	1298	1525	1273	480					ST3C2N1331
48000	1410	1260	1410	1220	355	150	350	320	3X27X1190	ST3C1N1534
	1525	1298	1525	1273	480					ST3C2N1534

C PORTATA DI 6 BALESTRE CAPACITY OF 6 SPRINGS
 E PASSO WHEEL BASE
 D ALTEZZA A VUOTO HEIGHT WHEN EMPTY

TANDEM

Balestra - Spring 100 mm

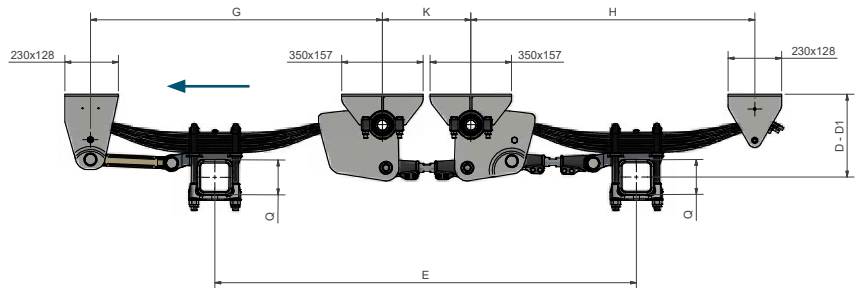
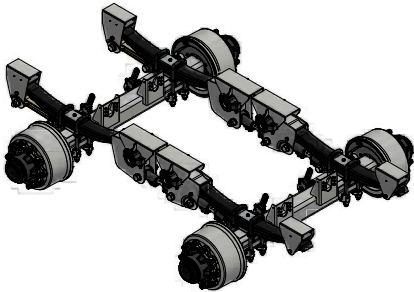

C (kg)	E (mm)	G (mm)	H (mm)	K (mm)	ASSALE Axle	D (mm)	D1 (mm)	BALESTRA Spring	CODICE - Code
32000	1810	1255	1220	380	150	355	325	3x27x1190	ST2D1N1535
	1850	1255	1220	420	150	355	325		

C PORTATA DI 4 BALESTRE CAPACITY OF 4 SPRINGS

TRIDEM

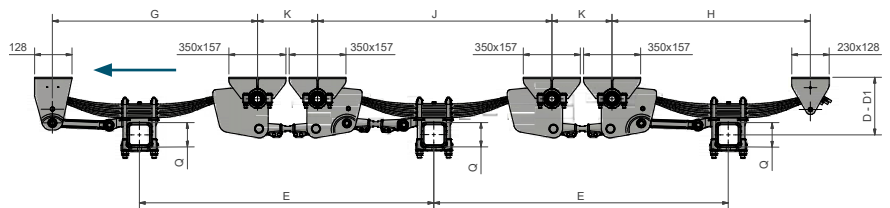
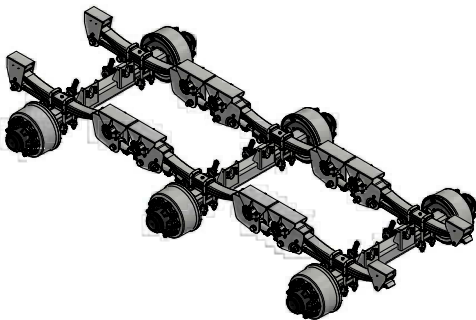

C (kg)	E (mm)	G (mm)	J (mm)	H (mm)	K (mm)	ASSALE Axle	D (mm)	D1 (mm)	BALESTRA Spring	CODICE - Code
48000	1810	1260	1440	1220	370	150	350	320	3x27x1190	ST3D1N1535
	1850	1260	1440	1220	410	150	350	320		

C	PORTATA DI 6 BALESTRE	CAPACITY OF 6 SPRINGS
E	PASSO	WHEEL BASE
D	ALTEZZA A VUOTO	HEIGHT WHEN EMPTY
D1	ALTEZZA SOTTO CARICO	HEIGHT WHEN LOADED



SOSPENSIONI PNEUMATICHE

pneumatic suspensions

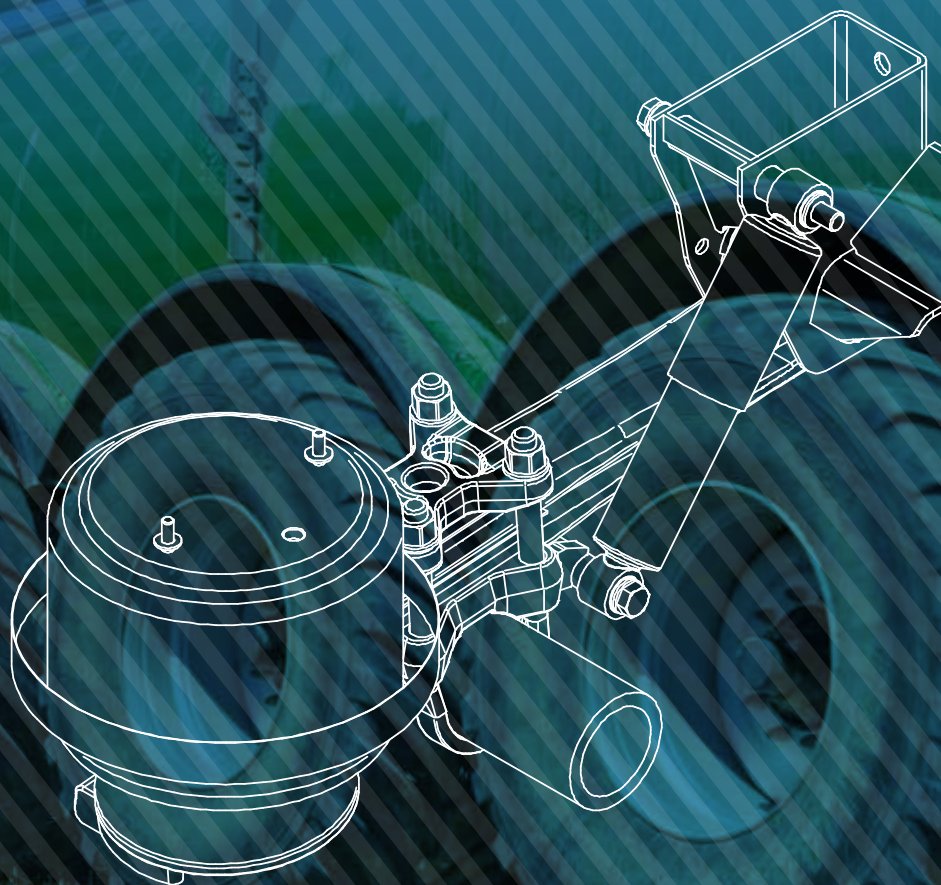



Sospensioni pneumatiche _ Pneumatic suspensions

LE SOSPENSIONI PNEUMATICHE

Le sospensioni pneumatiche sono sospensioni integrate da soffietti in gomma rinforzata alimentati con aria compressa, offrono un comfort di marcia eccezionale rispetto ai normali sistemi a molla in acciaio.

Un apparato di questo tipo consente di impostare il livello di altezza del veicolo grazie al volume d'aria contenuto nei soffietti, ed è modulabile al punto di consentire la realizzazione di un veicolo con un numero illimitato di assi.

GAMMA SOSPENSIONI PNEUMATICHE TVZ

Moduli monoasse da 9 e 13 Ton

Altezze di marcia da 295 mm a 440 mm

Molle ad aria da Ø300 mm a Ø350 mm

FORNITURA

Le sospensioni TVZ vengono fornite smontate come kit, con i sottogruppi già montati.

Il contenuto del kit comprende:

- Attacchi al telaio anteriori
- Balestre
- Ammortizzatori
- Piastre sagomate tra assale e balestra
- Piastre dritte sopra balestra
- Cavallotti + dadi e rondelle
- Molle ad aria
- Attacchi molla ad aria al telaio
- Viteria varia

MONTAGGIO DELLE SOSPENSIONI PNEUMATICHE

E' importante, per evitare collassi strutturali del corpo dell'assale, che le saldature dei componenti della sospensione sugli assali siano eseguite evitando le zone di massima sollecitazione. Per assicurare la massima affidabilità, durata e sicurezza di tutti i componenti del veicolo è importante che gli assali vengano installati correttamente. L'allineamento degli assali è eseguito dal costruttore del veicolo, gli assali devono risultare paralleli tra di loro e paralleli con il trattore, questo garantisce un buon controllo del veicolo e una vita maggiore dei pneumatici. Per garantire la massima efficienza frenante e durata dei freni, ed evitare rumorosità e vibrazioni anomale, le leve freno devono avere lo stesso senso di rotazione dei pneumatici. Per eventuali mal funzionamenti o danni alle sospensioni, agli assali, ai freni o ai pneumatici, derivanti dal montaggio non corretto degli assali è responsabile solo l'installatore.

NOTE

Le altezze di marcia indicate in questo catalogo, si riferiscono al veicolo in piano.

THE PNEUMATIC SUSPENSIONS

The air suspensions are integrated suspensions with reinforced rubber bellows powered by compressed air, compared to normal steel spring systems they offer an exceptional ride comfort.

An apparatus of this type allows to set the height level of the vehicle thanks to the air volume contained in the bellows, and can be modulated allowing the construction of a vehicle with an unlimited number of axles.

TVZ PNEUMATIC SUSPENSIONS RANGE

Single axle module 9 Tons and 13 Tons

Ride height from 295 mm to 440 mm

Air spring bellows Ø300 mm and Ø350 mm

SUPPLY

TVZ pneumatic suspensions are supplied disassembled as a kit, with the subassemblies already assembled.

The contents of the kit include:

- Anterior chassis fittings
- Springs
- Shock absorbers
- Shaped plates between axle and springs
- Flat plates mounted on the springs
- U-bolts + nuts and washers
- Air spring bellows
- Air springs fitting to the chassis
- miscellaneous screws

AXLE ASSEMBLY

In order to avoid the structural collapse of the axle body, it is extremely important that the welding of the suspension components on the axles do not take place in the areas of maximum stress. The correct installation of the axles is important to ensure maximum reliability, duration and safety of all the vehicle components.

The alignment of the axles is carried out by the vehicle manufacturer. The axles must be parallel with each other and with the tractor. This guarantees good vehicle control and a longer life of the tyres.

The brake levers must rotate in the same direction as the tyres to guarantee maximum braking efficiency and duration and to avoid noise and anomalous vibrations.

In case of any failure or damage to the suspensions, axles, brakes or tyres due to an incorrect assembly of the axles, the installer bears full responsibility.

NOTES

The heights indicated in this catalogue refers to the vehicle is in a horizontal position.



Sospensioni pneumatiche _ Pneumatic suspensions

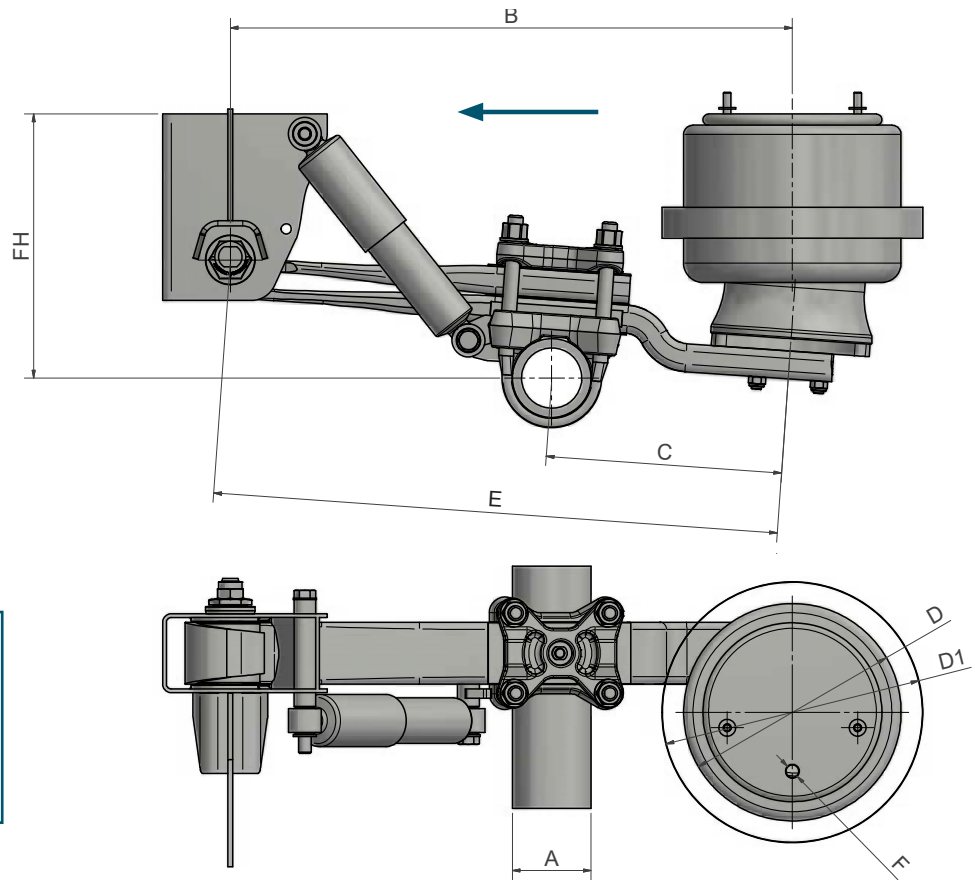

Attenzione: il disegno ha solo scopo illustrativo e può non rispecchiare l'immagine reale del prodotto.

Attention: the drawing is for illustrative purposes only, it may not respect the real image of the product.

PORTATA Capacity (kg)	A (mm)	FH (min-max) (mm)	D (mm)	D1 (mm)	B (mm)	C (mm)	E (mm)	F	CODICE Code
9000	Ø127	295-370	300	350	895	380	900	M22x1,5	Z6109295370380
13000	Ø127	395-440	350	420	905	380	910	M22x1,5	Z6113395440380

Attenzione: il modello da 9000 kg non è adatto per gli sterzanti - Attention: the 9000 kg model is not suitable for steering axles
La portata indicata è valida su 2 balestre - The capacity indicated is valid on 2 springs



OPTIONAL:
Kit sollevamento assale - Axle lift kit

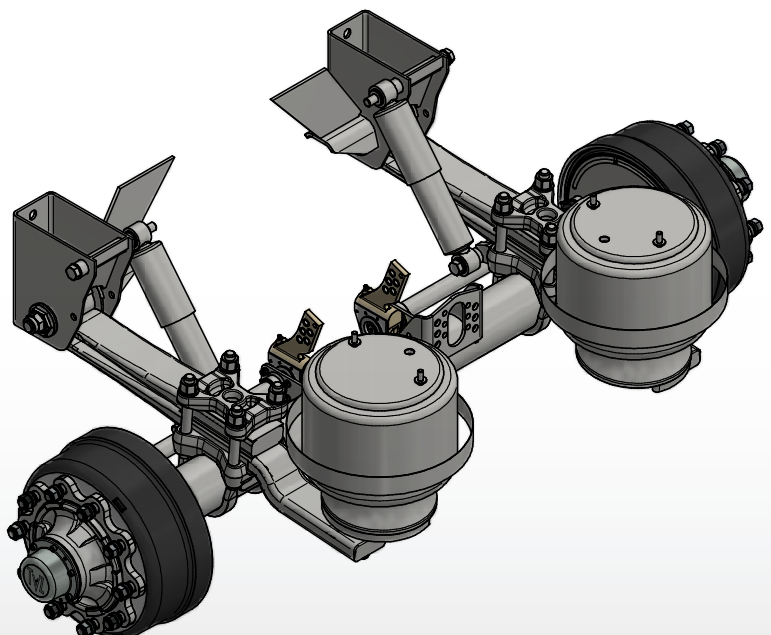

Copyright © 2019 by TVZ S.r.l. All rights reserved.

Tutti i diritti riservati. Nessuna parte di questo catalogo può essere riprodotta, memorizzata in un sistema di recupero o trasmessa in qualsiasi forma o con qualsiasi mezzo (elettronico, meccanico, fotocopie, o in altro modo) senza il preventivo consenso scritto di TVZ S.r.l.

All rights reserved. No part of this catalogue may be reproduced, stored in a retrieval system, or transmitted in any form or by any means (electronic, mechanical, photocopying, or otherwise) without the prior written permission of TVZ S.r.l.

A fronte di una continua ricerca tecnologica i dati possono cambiare senza preavviso.
Contattare il nostro ufficio commerciale per ulteriori informazioni.

*Because of continuous technology research data can change without notice.
Please, contact our sales departement for further information.*

Printed in Italy
Graphics and layout design by: Art&image (BS)



2020  



T.V.Z. S.r.l.

Via Gianbattista Meli, 118 - 25013 Carpenedolo (BS) ITALY

Tel +39 030 9699211 - Fax +39 030 9699220 - info@tvzassali.it

www.tvzassali.it