

loading platform

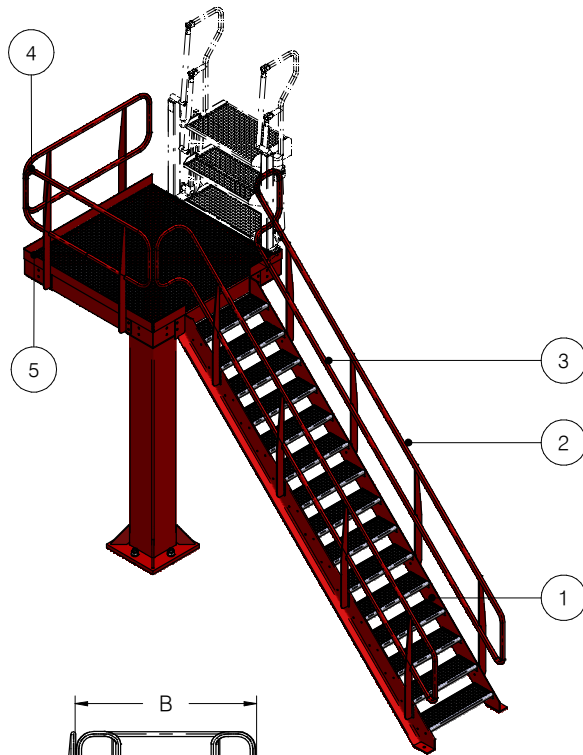

STANDARD RANGE	OPTIONS
height 3200 - 4400 mm	equipment up to 3 loading
steps galvanised	arms and 2 folding stairs
construction coated/galvanised	2 flight stair with intermediate
handrailing on both sides	landing
knee guides	
kick plate	

No.	NAME
1	nonskid steps
2	handrailing
3	knee list
4	railing
5	kick plate

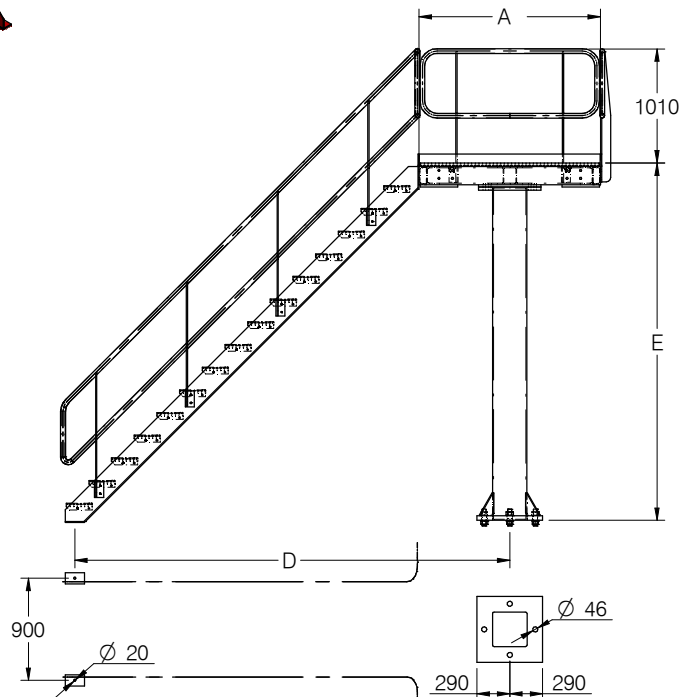
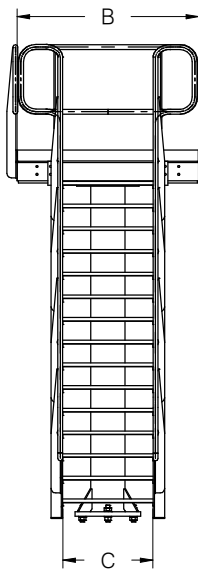

MODEL	STEPS	DIMENSIONS					LIVE LOAD		STAT. LOAD ON BASE PLATFORM		STAT. LOAD ON BASE STAIR	
		A	B	C	D	E	kg	kN	kN	kNm	kN	kNm
		mm	mm	mm	mm	mm						
3200	15	1600	1600	800	3836	3200	1250	12,74	23,7	15,7	2,9	0
3400	16	1600	1600	800	4036	3400	1290	13,15	24,0	15,7	2,9	0
3600	17	1600	1600	800	4236	3600	1330	13,56	24,3	15,7	2,9	0
3800	18	1600	1600	800	4436	3800	1370	13,97	24,5	15,7	2,9	0
4000	19	1600	1600	800	4636	4000	1410	14,38	24,9	15,7	2,9	0
4200	20	1600	1600	800	4836	4200	1450	14,79	25,2	15,7	2,9	0
4400	21	1600	1600	800	5036	4400	1500	15,29	25,5	15,7	2,9	0

subject to technical modifications